



# Manual for Rehabilitation of Large Dams

Doc. No. CDSO\_MAN\_DS\_02\_v1.0

**January 2018**



**Central Water Commission  
Ministry of Water Resources,  
River Development & Ganga Rejuvenation  
Government of India**

**Front cover photograph:** Krishna Raja Sagara Dam, Karnataka.

The Krishna Raja Sagara Dam was constructed across Cauvery River near Kannambadi village in the Mandya district of Karnataka during the period 1911 – 1931 and is almost 100 years old. It consists of a gravity dam constructed in stone masonry with surkhi mortar. The dam is 2621 m long and has a maximum height of 44.66 m above the deepest foundation level.



Government of India  
Central Water Commission  
Central Dam Safety Organization

# Manual for Rehabilitation of Large Dams

**January 2018**

Dam Safety Rehabilitation Directorate  
3<sup>rd</sup> Floor, New Library Building  
R. K. Puram  
New Delhi - 110066

Government of India  
Central Water Commission  
Central Dam Safety Organization

Disclaimer

Rehabilitation of a dam is the act of restoring the distressed dam not only to its original state but improvement to meet added requirements caused by changes in the safety criteria from time to time. Under the Dam Rehabilitation and Improvement Project (DRIP), the Central Water Commission (CWC) is coordinating rehabilitation of about 225 dams. The modus operandi adopted to assess the rehabilitation needs of various categories of dams and the rehabilitation process that followed were critically examined to incorporate the lessons learnt while formulating this *Manual for Rehabilitation of Large Dams*. Rehabilitation needs and circumstances vary for each dam and the approach is different for diverse types of dams. While every effort was taken to consider all the needs and circumstances, CWC cannot guarantee the efficacy of rehabilitation as that would depend on several factors beyond the scope of this manual. CWC absolves itself from any responsibility in this regard and dam owners and others involved with the dam rehabilitation activity should use their discretion in implementing the guidelines contained in this manual.

*For any information, please contact:*

The Director  
Dam Safety Rehabilitation Directorate  
Central Dam Safety Organization  
Central Water Commission  
3rd Floor, New Library Building (Near Sewa Bhawan)  
R. K. Puram, New Delhi – 110066.  
Email: dir-drip-cwc@nic.in



## MESSAGE

The water resources sector in India is one of the most important sectors which requires special attention. Along with the ever increasing pressure of the population and rapid pace of urbanisation with the towns and cities spreading by the day there is an exponential increase in water demand. Owing to the monsoon type of climate, almost the entire water supply to the country in the form of rainfall takes place in the limited span of four months or less. In view of climate change, dams and reservoirs will have to play an even more important role as mitigation and adaptation infrastructures by way of creation of adequate storages in order to satisfy the vital needs of water, energy and food. It is a general requirement to ensure availability of water, energy and food security by integrating management and governance across different sectors.

In order to handle varied challenges, it is utmost essential that the existing water storage assets of more than 300 billion cubic meter remain in sound health and safe condition, and deliver all intended benefits i.e. water supply, irrigation, hydropower, flood and drought mitigation as long as possible. In the present time, constructing a new dam is very challenging, given the population density and intensive land use, as also a host of other factors. The dam safety management, therefore is essential to ensure water and food security. The safe operation of dams and reservoirs through latest dam safety concepts is the need of hour to comprehensively address the dam safety management.

There are many aspects involved in dam safety management and publication of important technical guidelines and manuals is one of the important requirements. While there is a whole body of knowledge and experience available for creating new infrastructure, there is a gap in the field of rehabilitation of distressed dams. The current set of guidelines being prepared under Dam Rehabilitation and Improvement Project (DRIP) is an attempt to bridge the gap in the relevant standards of the country by bringing in the flavour of the best of international standards, specifically carved out to meet the Indian needs. This manual, prepared based on the earlier experience and challenges encountered during the ongoing DRIP, as well as current world wide practices, will prove a handy tool to the dam owners for reference while planning any rehabilitation work. Further there is a need to document all the best practices for rehabilitating the aging dams in the country. The current Manual for Rehabilitation of Large Dams is expected to fulfil the expectations of dam owners in that direction.

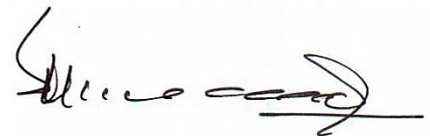

(S Masood Husain)  
Chairman

Central Water Commission

New Delhi  
January 2018

This page has been left blank intentionally.

## FOREWORD

History shows that the economic prosperity of a society and its cultural wealth has always been closely related to the level of the development of the water infrastructures. Presently accepted worldwide vision is “Better dams for a better world”. Dams and reservoirs are among critical infrastructures, whose failure may have catastrophic consequences with risk of fatalities and high economic losses. Dams are considered to be safe if risks are kept under control through appropriate measures. The dam safety concept comprises of three important components: structural safety, surveillance and maintenance, and emergency planning. In order to achieve a high level of safety, a dam needs to be designed and constructed in a manner that ensures that it remains stable for all conceivable load combinations and operational conditions. The risk can be minimised by a reliable surveillance system for early identification of any form of deterioration of the dam, and any unanticipated occurrences, and by a maintenance programme aimed at preventing such occurrences. However, it is not possible to eliminate all risks. Thus the field investigations, material selection for rehabilitation of concrete & masonry dam and embankment dams and appurtenant works become important for planning and finalizing rehabilitation programme.

Presently India ranks third globally having 5254 large dams in operation and 457 under construction. Also storage created by these structures renders reliable security for water, food, energy and mitigation of droughts and floods. In Indian context with ever increasing population and limited water resources, upkeep of these assets is very essential through excellence in engineering sciences and management. The integrated dam safety concept is a synthesis of so many activities; important ones is the enactment of legislation and proper system of technical regulations in place. The publication of *Manual for Rehabilitation of Large Dams* is long pending need of dam owners in India for providing guidance for execution of various activities related to rehabilitation and to address them systematically and scientifically.

Today about 200 large dams in India are more than 100 years old, and each year this number is increasing spirally. These dams along with other dams need a sound system of rehabilitation practices, identification of the requirements, Design and Execution of Rehabilitation works with Quality Control and Quality Assurance. Experience gained earlier as well as during DRIP implementation has been utilized in preparation of this *Manual for Rehabilitation of Large Dams*.

I hope that professionals engaged in the operation, maintenance, and rehabilitation of dams will find this manual very useful for managing the rehabilitation of their dams. I compliment all the individuals who have contributed to the development of this manual and hope that the efforts will go a long way in improving the dam safety environment in the country. Central Water Commission also acknowledges the special support extended by World Bank in accomplishing these objectives and especially thank Mr. Jun Matsumoto, past Task Team Leader, DRIP as well as Dr. C Rajgopal Singh, present Task Team Leader, DRIP and their team for extending excellent support all the time.

New Delhi  
January 2018

  
(N K Mathur)  
Member (Design & Research)  
Central Water Commission

This page has been left blank intentionally.

## PREFACE

The joint effect of aging/non-compliant structures, outdated past design practices, rapid downstream development coupled with increase in extreme meteorological events demands a fully funded and staffed dam safety programs, as well as sufficient funding for dam repairs. Dam inspection programs routinely find deficiencies in dams, but inspections alone are not a remedy for these deficiencies. Without proper maintenance, repair and rehabilitation, a dam may not be able to serve its intended purpose and could be at significant risk of failure. Responsibility for keeping dams functioning properly lies with the dam owners. Delays in repairing unsafe dams increases the probability of disasters which can otherwise be prevented by timely action.

Rehabilitation of large dams is required to counter various deficiencies which develop with time and also to correct inadequacies on account revisions in various standards/guidelines. Deficiencies that are caused primarily by the ageing of a dam include degradation caused due to weathering, wear & tear of equipments due to normal use or misuse, loss of serviceability with prolonged operation, damage from natural events including floods, earthquake or landslides, damage from vandalism and war etc.

Dam rehabilitation is a practice that is developing rapidly with availability of new materials for repair and with evolution of new construction techniques. As the number of India's ageing dams increases there will be an increasing demand for rehabilitation of dams. Further new techniques are being developed for carrying out rehabilitation works of existing dams without emptying the reservoir. Improvements in construction techniques that will allow owners to keep their dams in an acceptable condition at lower cost are evolving with time.

The Manual covers seven chapters viz. Overview of Dam Rehabilitation, Planning Aspects for Rehabilitation, Field Investigations for Dam Rehabilitation, Materials for Rehabilitation, Rehabilitation of Concrete and Masonry Dam, Rehabilitation of Embankment Dams and Rehabilitation of Appurtenant Works. It contains important details required for arriving at feasible rehabilitation programme incorporating best available worldwide practices. In addition, case histories for eleven important dam rehabilitation conducted earlier and under DRIP across the country have been included as a guide.

This Manual is intended for those who are responsible for maintenance of their dams and related structures and are required to plan, design & construct various rehabilitation works. The purpose of this Manual is to present an overview of the latest practices in dam rehabilitation, to highlight the major innovations, and to give enough references for the practicing engineers in India. Several case histories of dams being repaired and upgraded in the country are presented in Appendix A for reference.

This page has been left blank intentionally.



**Manual Review Committee**

<b>Chairman</b>	Gulshan Raj	Chief Engineer, Dam Safety Organization, Central Water Commission, New Delhi
<b>Past Chairman</b>	(i) N K Mathur	Former Chief Engineer, Dam Safety Organisation, Central Water Commission, New Delhi
	(ii) T K Sivarajan	Former Chief Engineer, Dam Safety Organisation, Central Water Commission, New Delhi
<b>Member Secretary</b>	Pramod Narayan	Director, Dam Safety Rehabilitation Directorate and Project Director, DRIP, Central Water Commission, New Delhi

**Committee Members**

M Ramesh Kumar	Director, Embankment Designs (North & West), Central Water Commission, New Delhi
Saibal Ghosh	Director, Concrete & Masonry Dam Designs (North & West), Central Water Commission, New Delhi
Vivek Tripathi	Director, Concrete & Masonry Dam Designs (East & North East), Central Water Commission, New Delhi
M Raghuram	Director, Hydrology (North), Central Water Commission, New Delhi
Ajay Mittal	Chief Engineer (Civil), National Hydro Power Corporation Ltd., New Delhi
Sanjeev Suri	Chief Engineer, Bhakhra Beas Management Board, Chandigarh
Neeraj Aggarwal	Deputy General Manager, Tehri Hydro Development Corporation India Ltd., Rishikesh, Uttarakhand
A K Ghosh	Scientist – D, Central Water and Power Research Station, Pune, Maharashtra
U S Vidyarthi	Scientist – D, Central Soil and Material Research Station, New Delhi
Sameer Kumar Shukla	Director, Dam Safety Monitoring Directorate, Central Water Commission, New Delhi
O P Gupta	Director, Foundation Engineering & Special Analysis Directorate, Central Water Commission, New Delhi

**Special Invitee**

Anil Jain	Director, Narmada Dam and Headworks Directorate, Central Water Commission, New Delhi
-----------	--

**Team Involved in Preparing this Manual**

---

Pramod Narayan	Director, Dam Safety Rehabilitation Directorate and Project Director, DRIP, Central Water Commission, New Delhi
Manoj Kumar	Deputy Director, Dam Safety Rehabilitation Directorate, Central Water Commission, New Delhi
Mayank Singh Chetan	Deputy Director, Dam Safety Rehabilitation Directorate, Central Water Commission, New Delhi
Saurabh Sharan	Deputy Director, Dam Safety Rehabilitation Directorate, Central Water Commission, New Delhi
Bikram Kesharee Patra	Assistant Director, Dam Safety Rehabilitation Directorate, Central Water Commission, New Delhi
Vinod Kumar Kapoor	Deputy Team Leader, Egis India, Consultant, DRIP
Chandra Shekhar Mathur	Dam Design Engineer, Egis India, Consultant, DRIP
Vinod Kumar Verma	Dam Safety Specialist, Egis India, Consultant, DRIP
Ajit Kumar Sachdeva	Hydro-Mechanical Expert, Egis India, Consultant, DRIP
Hemant Joshi	Design Engineer, Egis India, Consultant, DRIP
Vaibhav Singh	Design Engineer, Egis India, Consultant, DRIP
Pankaj Kumar Awasthi & Anil Kumar	Digital Support, Egis India, Consultant, DRIP

---

## CONTENTS

<b>Message</b> .....	<b>iii</b>
<b>Foreword</b> .....	<b>v</b>
<b>Preface</b> .....	<b>vii</b>
<b>List of Figures</b> .....	<b>xv</b>
<b>List of Tables</b> .....	<b>xvii</b>
<b>Acronyms</b> .....	<b>xviii</b>
<b>Chapter 1. Overview of Dam Rehabilitation</b> .....	<b>1</b>
1.1 Dam failures .....	2
1.2 Institutional Support for proper maintenance and rehabilitation of Dams .....	3
1.3 Purpose of this manual .....	3
1.4 Publication and Contact Information.....	3
1.5 Acknowledgments .....	3
<b>Chapter 2. Planning Aspects for Rehabilitation</b> .....	<b>5</b>
2.1 Design Aspects.....	5
2.2 Construction Aspects .....	6
2.3 Risk Management .....	7
2.3.1 Probabilistic Risk Analysis.....	7
<b>Chapter 3. Field Investigations For Dam Rehabilitation</b> .....	<b>9</b>
3.1 Phases of investigations .....	9
3.2 Minimum Design Studies required.....	9
3.3 Investigations & Testing.....	9
3.3.1 Embankment Dam.....	9
3.3.2 Concrete/Masonry Dams.....	11
3.4 Special Investigations .....	11
3.4.1 Geophysical Investigations for masonry/concrete dams for determination of permeable locations/zones.....	11
3.4.2 Geophysical Investigations for Embankment dams for determination of permeable locations/ zones.....	13
3.4.3 Determination of Site Specific Seismic Parameters.....	13
<b>Chapter 4. Materials for Rehabilitation</b> .....	<b>15</b>
4.1 Introduction.....	15
4.2 Methodology for Concrete Repair and Rehabilitation .....	15
4.3 Analysis of causes of distress & deterioration in concrete and their symptoms .....	16
4.3.1 Causes.....	16
4.3.2 Symptoms of Distress and Deterioration .....	16
4.3.3 Criteria for Selection of Repair Materials & Methodology.....	16
4.4 Repair Materials & their Suitability .....	16
4.4.1 High Performance Concrete .....	16
4.4.2 Bonding Agents .....	18
4.4.3 Cementitious Mortar for Structural repair [Based on EN 1504-3 (R4)].....	18

4.4.4 Free Flow Micro Concrete .....	20
4.4.5 Various Types of Grouts .....	20
4.4.6 Epoxy Compounds .....	20
4.4.7 Patching Materials.....	22
4.4.8 Resurfacing Materials .....	22
4.4.9 Steel Liner .....	23
4.4.10 Fiber Reinforced Concrete.....	23
4.4.11 Polymer Concrete and Coatings.....	23
4.4.12 Geo-Synthetic & Geomembrane as Sealing Systems for Dams.....	23
4.5 Materials for rehabilitation for bank protection.....	24
4.5.1 Poly Propylene rope gabions .....	25
4.5.2 Mechanically Woven Double Twisted Hexagonal Wire Mesh Gabion.....	26
4.6 Laboratory Studies on Epoxy / Cementitious Repair Materials.....	27
4.6.1 Mix Viscosity and Pot Life (IS: 9162).....	27
4.6.2 Compressive Strength (IS: 9162) .....	28
4.6.3 Tensile Strength (IS: 4456, IS: 9162).....	28
4.6.4 Penetrability .....	28
4.6.5 Bond Strength under Tension.....	29
4.6.6 Bond Strength with Concrete under Shear.....	29
4.6.7 Slant Cone Test (ASTM C-882).....	30
4.6.8 Flexure Test.....	30
4.6.9 Pressure Bearing Capacity of the Sealing System.....	30
4.6.10 Modulus of Elasticity (IS: 9221) .....	31
4.6.11 Bond Strength with Steel under Tension.....	31
4.6.12 Bond Strength with Steel under Shear .....	31
4.6.13 Bond Strength with Steel & Concrete under Tension .....	32
4.6.14 Abrasion Resistance of Epoxy Mortar (BS: 812).....	32
4.6.15 Flowability / Workability (IS: 2250) .....	32
4.6.16 Assessment of Strength Improvement.....	33
4.7 Laboratory Experimentation for Selection of Ideal Cementitious Grout System.....	34
4.7.1 Flowability test by Marsh Cone Apparatus.....	34
4.7.2 Settlement/Segregation Test.....	34
4.7.3 Gelification Test .....	34
4.7.4 pH Value .....	34
4.7.5 Compressive Strength.....	35
4.8 Test on Steel Fiber Reinforced Concrete (SFRC).....	35
4.8.1 Toughness Index (ASTM C-1018).....	35
4.9 Precautions to be observed during use of Repair Materials .....	38
<b>Chapter 5. Rehabilitation of Concrete and Masonry Dams .....</b>	<b>39</b>
5.1 Rehabilitation of the Foundation .....	39
5.1.1 Loss of strength under permanent or repeated actions .....	39
5.1.2 Erosion and Solution .....	41

5.1.3 Grout Curtains and Foundation Drains .....	42
5.2 Rehabilitation of the dam body .....	43
5.2.1 Chemical reactions resulting in swelling.....	43
5.2.2 Deficiencies on account of increased seepage.....	45
5.2.3 Shrinkage and Creep Leading to Contraction .....	52
5.2.4 Degradation at Dam Faces.....	52
5.2.5 Loss of strength because of repeated actions .....	53
5.2.6 Structural Joints.....	54
5.2.7 Pre-stressed structures .....	54
5.3 Improvement in Stability .....	55
5.3.1 Design Aspects.....	56
Annexure – I Recommended grouting guide/specification for rehabilitation of masonry/concrete dams.....	59
<b>Chapter 6. Rehabilitation of Embankment Dams .....</b>	<b>69</b>
6.1 Deformation .....	69
6.2 Seepage flows .....	70
6.3 Internal Erosion.....	70
6.3.1 Filters and Drains .....	71
6.3.2 Grouting.....	71
6.3.3 Diaphragm Walls and Cutoffs .....	73
6.3.4 Sheet Piling .....	75
6.3.5 Clay Blanket.....	75
6.3.6 Reconstruction and Replacement of the Core Section .....	75
6.3.7 New filters and Drain Provisions.....	76
6.4 External Erosion .....	76
6.4.1 Upstream Protection .....	76
6.4.2 Crest of the dam, Parapet walls & downstream slope of the Embankment Dam .....	77
6.5 Loss of Bond between Concrete Structure and Embankment.....	78
6.6 Slope Stability Improvement.....	78
6.7 Rehabilitation to Enhance Resistance to Seismic Effects.....	80
6.7.1 Rehabilitation Measures.....	81
6.8 Rehabilitation of Upstream Faces .....	81
6.8.1 Asphaltic Concrete Faces .....	81
6.8.2 Concrete Faces.....	82
<b>Chapter 7. Rehabilitation of Appurtenant Works.....</b>	<b>83</b>
7.1 Principal Causes of Deterioration.....	83
7.1.1 Local Scour .....	83
7.1.2 Erosion by Abrasion .....	84
7.1.3 Erosion by Cavitation .....	86
7.1.4 Obstruction by floating Debris in the Flow .....	88
7.2 Rehabilitation of Outlet Works.....	89

---

7.2.1 Outlet Tunnels and Conduits .....	90
7.2.2 Bottom Outlets .....	90
7.2.3 Rehabilitation of spillways and energy dissipaters .....	91
7.2.4 Protection of Abutments.....	93
7.3 Rehabilitation of Gates and Other Discharge Equipment's.....	93
7.3.1 General.....	93
7.3.2 Rehabilitation works including inspections/monitoring .....	95
7.3.3 Investigations/testing before rehabilitation works - Integrity Review Protocol Requirements.....	98
7.3.4 Protection Measures.....	99
7.3.5 Checks before and after rehabilitation.....	99
7.3.6 Photographs of some recent case histories.....	103
<b>References.....</b>	<b>107</b>
<b>Appendix A – Case Histories of Dam Rehabilitation In India.....</b>	<b>A1</b>
<b>Appendix B – Glossary of Terms for Dam Rehabilitation.....</b>	<b>B1</b>



## LIST OF FIGURES

Figure No.	Description	Page No.
1.1	Summary of the completion year of India's large dams (CWC 2016).	1
1.2	Year-Wise Number of Dam Failure in India	3
2.1	Global management of dams and reservoirs safety and links between the risk model and the Dam Safety file.	8
3.1	Typical Sonic Tomograms showing Velocity Contours and a view of the receiver points on downstream side	12
3.2	Typical Section showing Density values distribution in Dam section	13
4.1	Brookfield Viscometer Ford	27
4.2	Ford Viscosity Cup	27
4.3	Compressive strength test of cube specimen	28
4.4	Briquette/Dumbbell Shaped Specimen	28
4.5	Briquette/Dumbbell Shaped Specimen test in progress	28
4.6	Grouting of gap between beams and penetrability test	28
4.7	Grouting of gap between beams and penetrability test	29
4.8	Specimen for bond strength	29
4.9	Bond strength test in progress	29
4.10	Specimen for double shear	30
4.11	Double Shear Strength Test in Progress	30
4.12	Specimen for slant cone	30
4.13	Underwater water grouting of slant cone	30
4.14	Flexure Test in Progress	30
4.15	Specimen for Pressure Bearing Capacity	31
4.16	Pressure bearing capacity test in progress	31
4.17	Test set up for modulus of elasticity	31
4.18	Specimen for Bond Strength with steel	31
4.19	Bond Strength with Steel under Tension Test in Progress	31
4.20	Specimen for Bond Strength with steel under shear	32
4.21	Specimen for bond strength with steel and concrete in tension	32
4.22	Dorry's Abrasion Equipment	32
4.23	Flow-ability Test in Progress	33
4.24	Chipped off Concrete Cylindrical Specimen	33
4.25	Repair Mortar Application on Specimen	33
4.26	Flow-ability test by Marsh Cone apparatus in progress	34
4.27	Segregation test set up	34
4.28	Gelification Test Set-Up	34

4.29	pH Value Test Set-Up	35
4.30	Load Deflection Curve of FRC & normal concrete	36
4.31	Load Deflection Curve for determination of toughness index for FRC	36
4.32	Flexure test setup for measuring toughness index	37
4.33	Toughness index tested beams	37
5.1	Ajaure Dam, Sweden – Typical Cross Section	40
5.2	Chambon Dam, France - Slot Cuts	44
5.3	Treatment of Contraction Joints (Alternative-1)	50
5.4	Treatment of Contraction Joints (Alternative-2)	51
5.5	Details of Shear key	57
5.6	Sequence of Construction	57
5.7	Drainage Arrangement	58
6.1	Longbjorn Dam, Sweden - Cross section of abutment (Horizontal drains and stabilizing berm)	71
6.2	Grundsjon Dam, Sweden - Cross section of damaged core	76
6.3	Giffaumont Dam, France - Cross section of rehabilitated embankment	78
6.4	Ajaure Dam, Sweden – Typical Cross Section	79
6.5	Ajaure Dam, Sweden – Influence of d/s berm on factor of safety	80
7.1	Routine Site Instruments, Tools for H.M Works	98
7.2	Vertical Lift Gate	100
7.3	Spillway Radial Gates – Cross Section	101
7.4	Spillway Radial Gates – Downstream Elevation	101
7.5	Rope Drum Hoist	101
7.6	Gantry Crane	102
7.7	Inspection tools at site	103
7.8	Before Rehabilitation	104
7.9	After Rehabilitation	104
7.10	Strengthening of Spillway Radial Gates by Zinc Metalizing	105

**LIST OF TABLES**

Table No.	Description	Page No.
1-1	Year-wise figures for failures of Large Dams worldwide	2
4-1	Causes & Symptoms of Distress	17
4-2	Ingredients of High Strength Concrete	18
4-3	Repair method Recommended as per Damaged Depth of Concrete	18
4-4	Fields of application in accordance with ENV 1504-9	19
4-5	Performance Requirements as per EN: 1504-3 (R4)	20
4-6	Three Types of Epoxy and their application	21
4-7	Classes of epoxy and their use as per range of temperature	22
4-8	Mechanical properties of epoxy resin bonding system	22
4-9	Total dams with Geo-membrane	24
4-10	PVC-P Geo-composite Performance Requirements	25
4-11	Physical/ Mechanical properties of Polypropylene ropes	26
4-12	Value of Toughness Indices	37
5-1	Useful co-relation between the observed trends in seepage and in piezo-metric pressure.	41

## ACRONYMS

The following acronyms are used in this publication:	
ALARP	As Low as Reasonably Practicable
ASCE	American Society of Civil Engineers
ASR	Alkali-silica reaction
BDS	British Dam Society
BRE	Building Research Establishment
BSI	British Standards Institution
DSO	Dam Safety Organization
CIRIA	Construction Industry Research and Information Association
CWC	Central Water Commission
D&R	Design & Research Wing
DRIP	Dam Rehabilitation and Improvement Project
FMECA	Failure Mode, Effect, and Critically Analysis
HAZOP	Hazard and Operability
ICE	Institution of Civil Engineers
ICOLD	International Commission on Large Dams
PAR	Population at Risk
PMF	Probable Maximum Flood
PMP	Probable Maximum Precipitation
SDSO	State Dam Safety Organization
USACE	U.S. Army Corps of Engineers
USBR	U.S. Bureau of Reclamation
USCOLD	U.S. Commission on Large Dams
USSD	U.S. Society on Dams

## Chapter 1. OVERVIEW OF DAM REHABILITATION

Dams are constructed for utilization of river waters for irrigation, flood-control, hydro-power development, domestic and municipal supplies etc. Over the last fifty years, India has invested substantially in dams and related infrastructures. At independence, in 1947, there were fewer than 300 large dams in India; but, now there are 5254 large dams completed and another 447 dams that are under construction (NRLD 2017) – besides several thousands smaller dams. India now ranks third in the world in dam building, after China and USA (ICOLD 2017).

Post-independence, a substantial number of dams have been added and close to 80% of India's large dams have now become more than 25 years old. Besides, there are 213 large dams which are over 100 years old. Figure-1-1 shows the journey of dam building activity in India.

A substantial proportion of Indian dams have now become old. Like all pieces of infrastructure, dams age and deteriorate, posing a potential threat to life, health, property, and the environment. Lack of maintenance, upstream and downstream development and weather amplify the problems. Many of these ageing dams have various structural deficiencies and shortcomings in operation and monitoring facilities, while few of them do not meet the present design standards – both structurally and hydrologically. Thus, an increasing number of dams fall in the category where they need rehabilitation. Safety of these dams is very important for safeguarding the national investments and the benefits derived.

Without proper maintenance, repairs, and rehabilitation, a dam may not be able to serve its intended purpose and could be at risk for failure. State Govt. and other dam owning agencies can identify deficiencies in dams through regular inspection programs, but inspections alone will not address safety

concerns posed by inadequately maintained or deficient dams.

A “deficient dam” is one that does not meet the minimal dam safety standards and that poses an unacceptable risk to the public. The term “rehabilitation” means the repair, replacement, reconstruction, or removal of a dam that is carried out to meet applicable dam safety standards.

Establishment of good dam safety practices will involve rehabilitation of deficient dams with interventions such as:

- Seepage control through masonry and concrete dams and reduction of seepage through dams and their foundations, and improving dam drainage;
- Rehabilitation of embankment dams in poor condition for deficiencies such as cracking in dam, piping, excessive seepage, disturbed rip-rap,

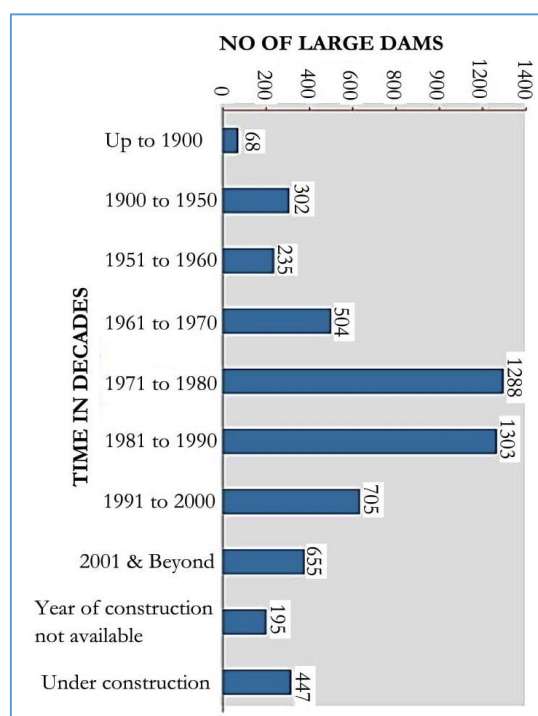

Figure 1-1: Distribution of large dams in India decade-wise (CWC 2017).

rain cuts, vegetation etc.

- Structural strengthening of dams, where required;
- Rehabilitation and improvement of spillways, head regulators, draw-off gates and their operating mechanisms, stilling basins, and downstream channels;
- Increasing spillway capacity as required by hydrological reassessments, in cases where they are physically possible, otherwise non-structural measures to be worked out;
- Improving approach roads; communication facilities, improving dam safety instrumentation and implementation of emergency and disaster management plan

## 1.1 Dam failures

As per an ICOLD publication – Lessons from Dam Incidents (1973) – there have been about 200 notable failures of large dams in the world up to 1965 (see Table 1-1 below).

A more detailed statistical analysis of 179 dam failures by ICOLD (1995) indicates that the percentage of failure of large dams has been falling over the last four decades – about 2.2% of dams build before 1950 have failed while the failure rate of dams built since 1951 has been less than 0.5%. It was also noted that most failure involved newly-built dams – over 70% failures occurred chiefly in the first ten years, and more especially in the first year after commissioning.

In concrete dams foundation problems are the most common cause of failure with internal erosion (alternating stresses leading to foundation deformations, changes in hydraulic gradients leading to washing of joint fillings, shear zone and fault materials, solutioning of weak rocks like limestones and gypsum, damaged grout curtain, choked foundation drains etc.) and insufficient shear

Table 1-1 Year-wise figures for failures of Large Dams worldwide

Year	Approximate number of significant failures
Prior to 1900	38
1900 to 1909	15
1910 to 1919	25
1920 to 1929	33
1930 to 1939	15
1940 to 1949	11
1950 to 1959	30
1960 to 1965	25
Date unknown	10
<b>Total</b>	<b>202</b>

strength of the foundation/abutments (sliding along dam base, weak planes in the foundations) each accounting for 25 per cent.

With earth and rock fill dams, the most common cause of failure is overtopping (31 per cent as primary cause and 18 per cent as secondary cause), followed by internal erosion (piping) in the body of the dam (15 per cent as primary cause and 13 per cent as secondary cause) and in the foundation (12 per cent as primary cause and 5 per cent as secondary cause).

India too has had its share of dam failures. The first such failure was recorded in Madhya Pradesh during 1917 when the Tigr Dam failed due to overtopping. As per dam failure records maintained in Central Water Commission (CWC), in all there have been 36 reported failures since then. Maximum number of dam failures has been reported over two decades corresponding to the period 1951 to 1970, as illustrated in Figure 1-2. An analysis of this data shows that most of the failures have been in respect of earth dams (30 failures) plus a few composite dams (3 failures). Only three failures have been reported for masonry dams in the last 90 years, while none of the concrete dam has failed.



The most common causes of Earth dam failure in India have been overtopping, piping through dam body/foundation & slope failure.

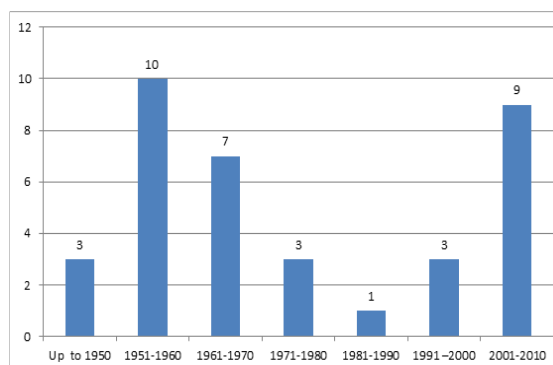

Figure 1-2: Year-Wise Number of Dam Failure in India

Knowing the causes of failure and requisite analysis helps to structure the future dam safety programme. Investigations of such failures have also confirmed that a majority of failures could have been avoided by proper design, construction and regulation. It therefore becomes a national responsibility to see that manmade reasons for the possibility of dam failures are minimized, and their consequence on the unsuspecting people is avoided.

## 1.2 Institutional Support for proper maintenance and rehabilitation of Dams

For ensuring continued benefits from the dam, a constant periodic surveillance and corrective measures will be needed to be implemented by the States for which fund constraints are routinely experienced, as specific rehabilitation measures may far exceed the allocations available out of normal O&M funds. Adequate funds for maintenance and up-gradation of dams will be needed on regular basis to maintain these structures in good and safe condition.

There is an urgent need in the country for institutional strengthening and giving adequate importance to support regular maintenance. Sensitizing the organization with the

responsibility of operation and maintenance for the dam infrastructure is certainly more effective than to provide expensive aid to undertake large rehabilitation works. Good quality maintenance procedures, faithfully executed are important in combating the need for expensive rehabilitation.

## 1.3 Purpose of this manual

The purpose of this Manual is to provide an overview of the latest practices in dam rehabilitation, to highlight the major innovations, and to give enough references for the benefit of Indian Engineers. Several case histories of dams repaired and upgraded in India both under the Dam Rehabilitation and Improvement Project (DRIP) and earlier to illustrate modern, innovative means of rehabilitating dams are presented in Appendix A for reference.

## 1.4 Publication and Contact Information

This document is available on the CWC web site (<http://www.cwc.gov.in>) and in the Dam Rehabilitation and Improvement Project (DRIP) website (<http://www.damsafety.in>).

For any further information contact:

The Director  
 Dam Safety Rehabilitation Directorate  
 Central Dam Safety Organization  
 Central Water Commission  
 3rd Floor, New Library Building  
 R. K. Puram, New Delhi – 110066  
 Email: [dir-drip-cwc@nic.in](mailto:dir-drip-cwc@nic.in)

## 1.5 Acknowledgments

In preparing this manual, work of others in India, the United States, and elsewhere has been drawn from liberally. Grateful appreciation is extended to the following organizations whose publications and websites have given valuable information on various aspects of dam rehabilitation:

- International Commission on Large Dams (ICOLD)
- United States Society on Dams (USSD)
- U.S. Army Corps of Engineers (USACE)
- U.S. Bureau of Reclamation (USBR)
- British Dam Society (BDS)
- American Society of Civil Engineers (ASCE)
- Institution of Civil Engineers (ICE)
- Bureau of Indian Standards.
- Central Board of Irrigation & Power.

## Chapter 2. PLANNING ASPECTS FOR REHABILITATION

In this chapter the planning aspects involved in rehabilitation of dams and their appurtenance structures are discussed.

The rehabilitation should be programmed to first deal with critical works to make the structure safe and operable. Adequate investigations are desirable for carrying out rehabilitation designs and avoiding surprises. Risk analysis is in these days becoming popular, especially in the developed countries, for prioritizing of works.

Good practices generally adopted world-wide for dam safety monitoring typically require that:

- Inspections of the dam, reservoir and the downstream areas should be carried out on a regular basis. For details refer Guidelines for safety inspection of dams, CWC (2018). When any unusual behavior is noted, independent inspections by expert panels may be got conducted, as necessary.
- Sufficient monitoring equipment in dams is desirable to allow a basic assessment of the behavior of the structure & its foundations.
- Measurement data should be evaluated on a regular basis and structural behavior reports should be prepared.

A regular program of inspections & maintenance can go a long way in reducing major rehabilitation works in future.

### 2.1 Design Aspects

The requirement for rehabilitation is generally based on the observations/ recommendations brought out in various inspection reports of the project. Various factors which are taken into account are:

- Reports of earlier comprehensive and other inspections.
- Condition of the dam & appurtenant structures.
- Performance/condition of Hydro-Mechanical equipment.
- Evaluation of instrumentation data.
- Photographs taken at different points of time.
- Original designs & drawings, material properties considered.
- Details of any earlier dam incident including rehabilitation works carried out.
- Risk analysis, if carried out.
- Further investigations, as required.

Rehabilitation options which will need to be considered will include:-

- Continued monitoring of the structure through additional instrumentation, inspections etc.
- Carry out additional studies & investigations to determine the actual position & to work out rehabilitation plan.
- Immediate steps required like lowering of FRL, for handling of emergent situations which have a direct impact on dam safety, repairs of spillway gates etc.

The following factors will also need to be considered while formulating rehabilitation plans:

- Review of design flood studies which may suggest an increase in spillway capacity.
- Revised water availability studies which may suggest an in-

- crease/decrease in hydro-electric capacity, irrigation or water supply.
- Impact of any recently constructed projects on the upstream.
- Reservoir operation experience of the operating personnel in respect of Hydro-Mechanical equipment etc.
- Any changes in river morphology.

It is difficult to affect closure of any important hydraulic structures for long periods. Planning has to also take into account the operational constraints. As such the investigations (as required) and the rehabilitation works will need to be planned accordingly so as not to cause delays.

Foresight is needed to know that what data will be required and when. Experienced personnel are required.

When the available data has been analyzed and the problems identified, a feasibility study needs to be carried out to find possible solutions. Discussions involving experts/personnel from different connected disciplines are desirable. Solutions are usually compared based on techno-economic considerations.

Arrangements for financing of the rehabilitation work is equally important. The source of funding depends on several factors. If there are definable and reliable funds for the project, it may be possible to arrange private financing in which an investor takes an equity share in the project for an agreed period. Where the funds are neither well-defined nor reliable, grants or loans from a funding agency may have to be resorted to. The financial arrangements depend on how the rehabilitation project may be structured into fundable contracts without affecting the progress of the works unfavorably.

The following factors will also need to be taken into account when carrying out the detailed design of rehabilitation works.

- Consideration of construction techniques.
- The effect of the methods of rehabilitation which might include grouting, pre-stressing, blasting etc. on the existing structure.
- The effect of using materials that have different properties than the original materials on the structure.
- Mitigation of environmental impact.

## 2.2 Construction Aspects

Surprises are common in rehabilitation works. A good contract for rehabilitation work, therefore, requires that the work is defined accurately. The selected form of contract must be fair for both parties, minimizing the points of conflict, and allowing quick and equitable agreement on additional items. Alternative forms of contract for rehabilitation work include: item rate contract, turnkey contract & EPC contract.

Careful structuring of pre-qualification documentation ensures that the owner and the funding agency receives proper information to judge which contracting companies are to be included in the tendering list. Joint ventures can also be considered, both through National & International agencies. The form of the joint venture can be specified in the contract. Specialized agencies should be preferred for execution of item of works of special nature. For such works performance warranty of suitable duration (around 5 to 10 years) should be obtained from the agency.

The Engineer-in-charge apart from Construction supervision, Quality Control and Quality Assurance would also prepare periodical progress reports to ensure that the works are adhering to the construction schedule. Experience is required to predict problems before they arise and to arrange for the necessary data to be collected in a timely manner. The site supervisory team must be organized so that every item of

rehabilitation works is supervised. Each position in the team carries well-defined responsibilities. The Engineer-in-charge should have sound technical skills and contract management experience. It is to be ensured that best practices of achieving quality of rehabilitation works are adopted including OK card system for all important works.

## 2.3 Risk Management

Risk Management is being covered in a separate Guideline. Only an overview is presented here.

Risk Management has become increasingly popular in developed countries for identification and quantification of potential threats to the works, and to manage the risk effectively (Hartford and Batchner 2004). This allows better decisions to be made concerning the rehabilitation of ageing structures, considering both the value of the asset to the business and the safety of the public (Combelles 1991). There is often inadequate operating data available to assess failure frequency, underlining the value of experience and generalized statistical data. It also emphasizes the importance of a comprehensive database of operating incidents in a project.

The main purpose of assessing risk in dams that need to be rehabilitated is to prioritize them in order to effectively reduce the risk, integrating in the assessment all the dam safety aspects (i.e. monitoring, health, maintenance, emergency action plan, operation rules etc.) which normally are analyzed separately. Several approaches to risk analysis have been proposed to supplement the direct method of visual inspection, analysis, and reporting which suffer from the limitation that they can principally identify only those defects that have already developed. Any of the approaches based on the decision making process of the risk models is shown in Fig.2.1.

### 2.3.1 Probabilistic Risk Analysis

Typical of the probabilistic approach applied to dams is the procedure detailed by Bowles et al. (1990) and Vick and Stewart (1996). This procedure involves listing all the failure scenarios that could happen as the result of a triggering event and using them to create an event tree. A probability of failure is then given to every stage of each scenario. Thus, the probability of each of the elements of the tree occurring is assessed, and the overall probability of each of the failure modes evaluated is calculated as the product of all the items in that branch of the tree.

This technique gives a quantitative risk of failure for every failure path and for each event that is possible. It is, therefore, feasible to use this to justify whether to carry out works based on a comparison of the calculated danger with a predetermined acceptable risk of loss of life or cost to the community or operator. It must, however, be borne in mind that the overall risk has been developed as a product of many components. A small error in each part may have a significant effect on the overall assessment. Calculation of the correct probabilities of failure for the various elements of the event tree can be difficult and usually involves significant costs.

None of the techniques can remove all risks. The aim is to reduce the likelihood of failure to a value that is *As Low as Reasonably Practicable* (ALARP). The basis for ALARP is that risks are acceptable only if practical measures have been taken to reduce risks. This is usually taken to mean that the risks have been reduced to the point where it is no longer cost effective to reduce them further.

With all the methods of risk assessment, the procedure should involve a team including engineers with experience in design, operations, and maintenance and may also require advice from specialists in hydrology, geology, and seismology to develop a comprehensive assessment. A site visit by the

team to inspect all aspects of the works is essential including discussions with the local operators, study of available construction drawings, operational records etc.

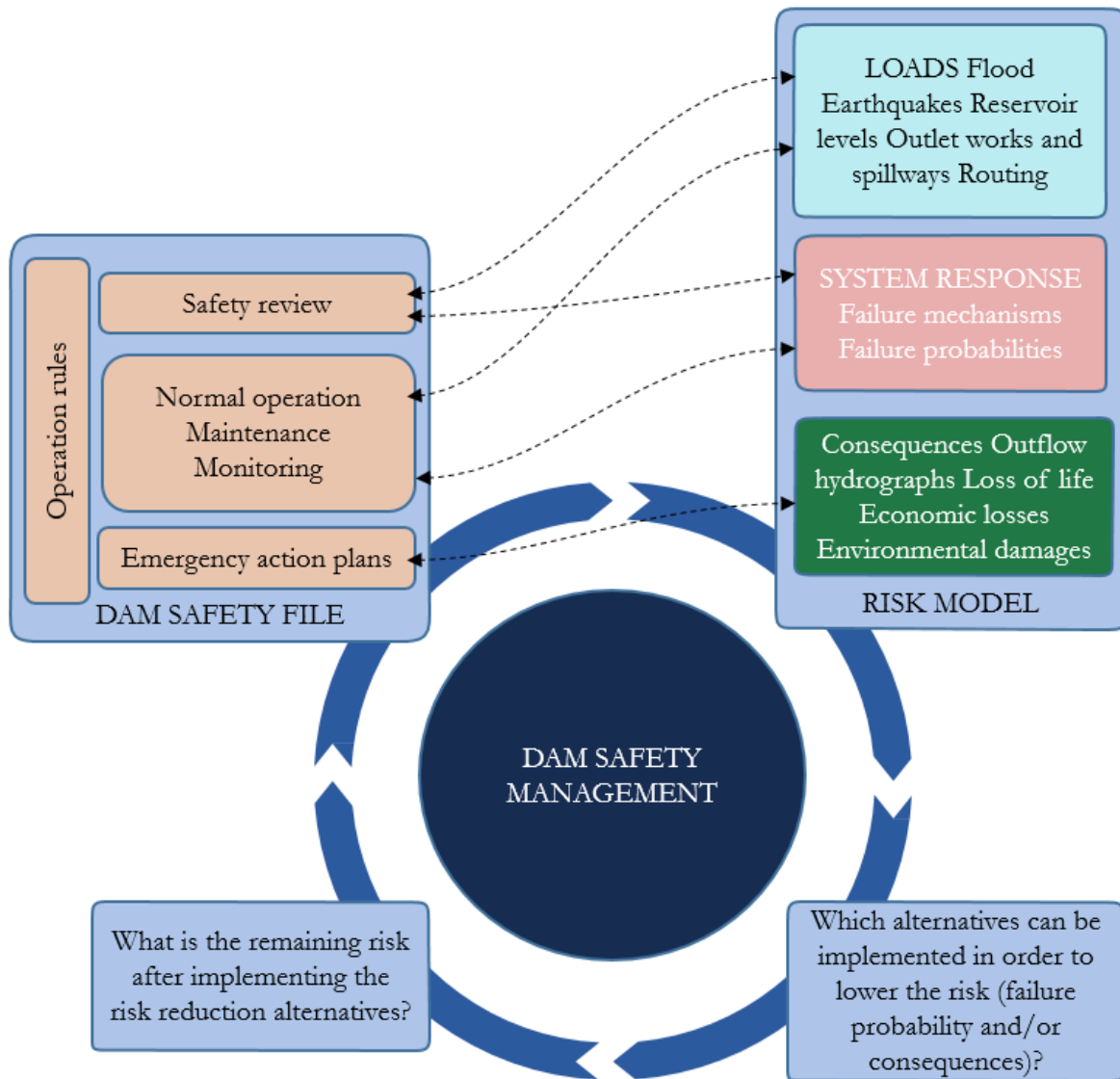

Figure 2-1: Global management of dams and reservoirs safety and links between the risk model and the Dam Safety file.



## Chapter 3. FIELD INVESTIGATIONS FOR DAM REHABILITATION

This chapter deals with the investigations required to be carried out for conducting detailed design studies and working out the rehabilitation plan based on findings of the inspection carried out.

### 3.1 Phases of investigations

Investigations of dam projects are proposed to be undertaken in two phases. Phase-I would be an inspection to assess the general condition of the dam and to determine the need for any additional engineering investigations and analyses. In this phase, a detailed review/study will be made of the existing and available engineering data relating to design, construction and operation of the dam and its appurtenant works including hydro-mechanical equipment along with instrumentation data and interpretation reports. Thereafter a detailed systematic visual inspection will be performed covering all features of the dam. All rehabilitation works can be identified based on Phase-I investigations.

The Phase-II investigation will be supplementary to Phase-I and should be conducted when the results of Phase-I investigation indicates the need for additional in-depth studies and further investigation or analyses necessary to evaluate the safety of the dam. Works involved may include additional inspections(if required), all necessary explorations and testing of materials both in the dam body and in the foundation and all design studies required to check the safety of the dam.

### 3.2 Minimum Design Studies required

- a) Review and determination of Revised Design flood viz. Probable Maximum

Flood (PMF), Standard Project Flood (SPF) or 100-year flood return period flood, on case to case basis.

- b) Determination of Maximum Water level for the revised design flood by Flood routing studies.
- c) Check for freeboard in the dam for the MWL condition.
- d) To check the need for any Structural / Non- Structural measures in case of any upward revision of design flood.
- e) Identification of site in case an additional spillway is required.
- f) All topographical & geological investigations for the selected possible additional spillway sites.
- g) Re-checking of freeboard considering the planned structural provisions.
- h) To carry out a seismic study for determination of seismic design parameters (if necessary) and to obtain approval from NCSDP, if required.
- i) Review of stability of the dam & spillway based on actual material properties etc.

### 3.3 Investigations & Testing

The Geotechnical investigations/tests to be carried out will depend upon the issues involved. A list of tests generally carried out for the embankment dams and concrete /masonry dams are given below.

#### 3.3.1 Embankment Dam

The following is a list of field & laboratory test that may be required to be conducted in respect of an existing embankment dam. Undisturbed samples will have to be taken out from the existing dam from desired locations & tested for various

parameters. As regards additional materials that may be required for strengthening/increase in dam section, suitable borrow areas will need to be identified. From these borrow areas disturbed samples can be taken for testing.

- Standard Penetration Test – As per IS: 2131
- Static Cone Penetration Test– As per IS: 4968 (Part - 3)
- Insitu Field Density Test
  - Determination of Dry Density of Soil In-Place by Core Cutter Method - As per IS: 2720 (Part-29)
  - Determination of Dry Density of Soils, In-Place, by Sand Replacement Method - As per IS: 2720 (Part-28)
  - Determination of Density of Soil In-Place by Rubber-Balloon Method - As per IS: 2720 (Part - 34)
  - Determination of the Density In-place by Ring and Water Replacement Method - As per IS: 2720 (Part-33)
  - Nuclear Density and Moisture Gauge Method
  - Permeability of the existing embankment In-situ Permeability Test - As per IS: 5929.
- Undisturbed Soil Samples
  - Mechanical Analysis - As per IS:2720 (Part-4)
  - Atterberg limits - As per IS:2720 (Part-5)
  - Soil classification - As per IS: 1498
  - Insitu Density/Natural Moisture Content - As per IS:2720 (Part - 29)
- Specific Gravity - As per IS:2720 (Part-3)
- Triaxial Shear Test - Consolidated Undrained test with Pore pressure measurement - As per IS:2720 (Part-12)
- Direct Shear Test As per IS:2720 (Part-13)
- Chemical analysis of soils
- Disturbed Soil Samples
  - Mechanical Analysis - As per IS:2720 (Part-4)
  - Atterberg limits - As per IS:2720 (Part-5)
  - Soil classification - As per IS 1498
  - Shrinkage Limit - As per IS:2720 (Part-6)
  - Standard Proctor Compaction - As per IS:2720 (Part-7)
  - Specific Gravity - As per IS:2720 (Part-3)
  - Triaxial Shear Test - Consolidated Undrained test with Pore pressure measurement - As per IS:2720 (Part-12)
  - One Dimensional Consolidation - As per IS:2720 (Part-15)
  - Laboratory Permeability - As per IS:2720 (Part-17)
  - Chemical Analysis of Soil
- Expansive Soils
  - Differential Free Swell Index Test - As per IS:2720 (Part-40)
  - Shrinkage Limit Test - As per IS:2720 (Part-6)
  - Swelling Pressure Test - As per IS:2720 (Part-41)
- Dispersive Soils

- Soil Dispersivity Identification Tests (As per standard procedures)
- Pin-Hole Test - As per ASTM D4647
- Double Hydrometer Test - As per ASTM D4221
- Crumb Test - As per ASTM D6572
- Chemical Analysis of Pore-Water Extract Test - As per ASTM D4542
- Chemical Analysis of Soil
  - pH - As per IS:2720-26
  - Total Soluble Salts - As per IS:2720 (Part-21)
  - Calcium Carbonate - As per IS:2720 (Part-23)
  - Water Soluble Sulphate - As per IS:2720 (Part-27)
  - Organic Matter - As per IS:2720 (Part-22)

### 3.3.2 Concrete/Masonry Dams

Representative cores will need to be extracted from the existing concrete/masonry dam for conducting necessary testing, as required. In general, the following tests may be required to be conducted.

- Non Destructive testing of concrete/masonry – As per IS 13311 (Part-I)
- Density of Concrete/Masonry
- Compressive strength of concrete/Mortar in masonry - As per IS 516
- Static Modulus of Elasticity of concrete masonry – As per IS 516
- Water Permeability of Concrete / Masonry - As per IS 11216/DIN 1048

- Chloride Content & pH of concrete – As per IS 456
- Corrosion activity in concrete
- Water Quality Analysis of the reservoir water / seepage water
- Splitting tensile strength of concrete- As per IS 5816

### 3.4 Special Investigations

This may be required for specific issues like determination of permeable locations in the dam for planning directional grouting or for conducting a seismic study to determine the site-specific seismic parameters.

#### 3.4.1 Geophysical Investigations for masonry/ concrete dams for determination of permeable locations/zones

IS:15681 Code of Practice for geological exploration by Geophysical Methods (Seismic Refraction Method) deals with various aspects of seismic refraction technique and its application to shallow subsurface exploration of engineering sites. The primary purpose of the standard is to provide working knowledge of the method, with relevant references, and with a basis to weigh the applicability of the method to various engineering geological problems. In particular, it seeks to provide an understanding of the proper planning of surveys, so as to obtain adequate and relevant coverage and highlight the most important area of interpretation of seismic data.

For concrete/masonry dams sonic tomography can be carried out where necessary (for existing dams).

The sonic methods envisage generation of elastic energy (P waves) using various sources which is propagated through the investigated structure.

The elastic waves are recorded by specific sensor(Accelerometer) in the form of electric signals.

For transverse dam sections, geophysics surveys are performed following sonic tomography methods with transmission points located on the upstream side (reservoir side) while the receiver point are placed on the downstream side.

To generate P waves a “sparker” source is used, that produces explosive energy from a spark pulse generated between two electrodes in salt water. The compressional wave is transmitted through the water and therefore to the investigated surface. Then sonic signal is recorded by the transducers (accelerometer) and transformed in electrical signal sent to surface through the connection cable.

Velocity analysis envisage estimation of time needed by the elastic impulse to cover the distance between the transmitter-receiver couple. Therefore the second step consists in time-distance processing of data set to calculate sonic velocity distributions and to estimate a tightly linked parameters with

elastic properties of investigated area.

The results of the processing are plotted as colored tomograms, which show the variations of the P-waves velocity field, along with the representation of the measuring paths as obtained from the ray-tracing processing.

Typical Low Velocity & Low-Density Zones with Sonic Tomography in a dam block are shown in Figure 3-1 & 3-2.

Another alternative is Ground Penetrating Radar.(GPR) survey which is conducted to identify shallow cracks, cavities and voids in the dam body based on contrast in Dielectric Constant. The method can be used to obtain high-resolution subsurface images showing cavities besides buried objects, cables pipes etc. The data of GPR is critical for interpreting Streaming Potential (SP) data and removal of voltage peaks generated due to buried metal objects, reinforcement etc.

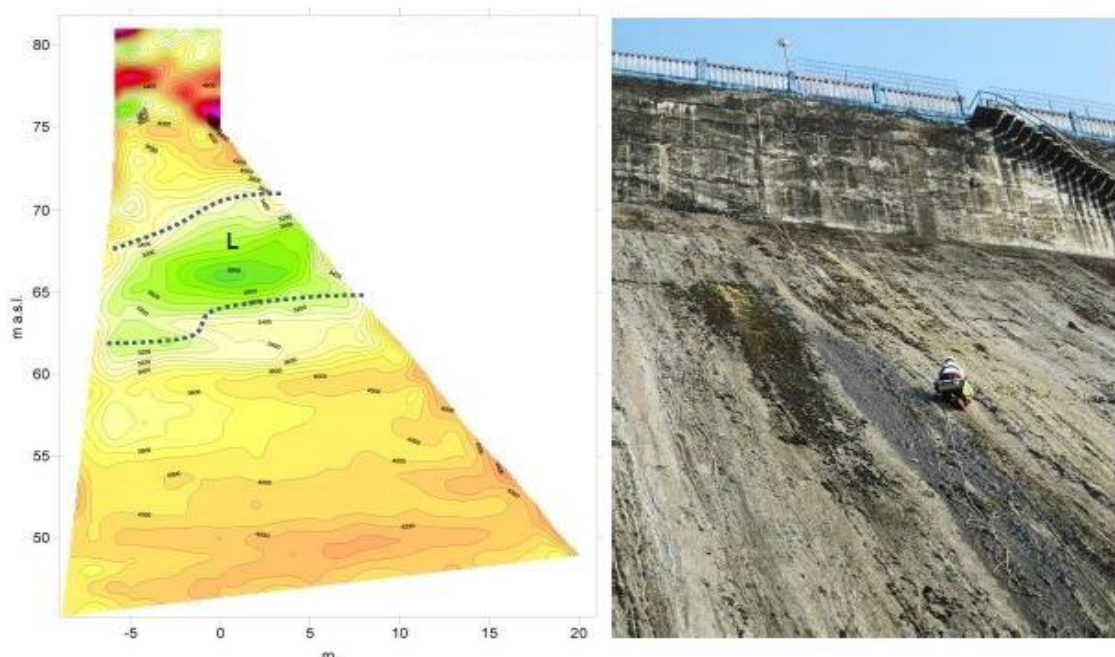

Figure 3-1: Typical Sonic Tomograms showing Velocity Contours and a view of the receiver points on downstream side

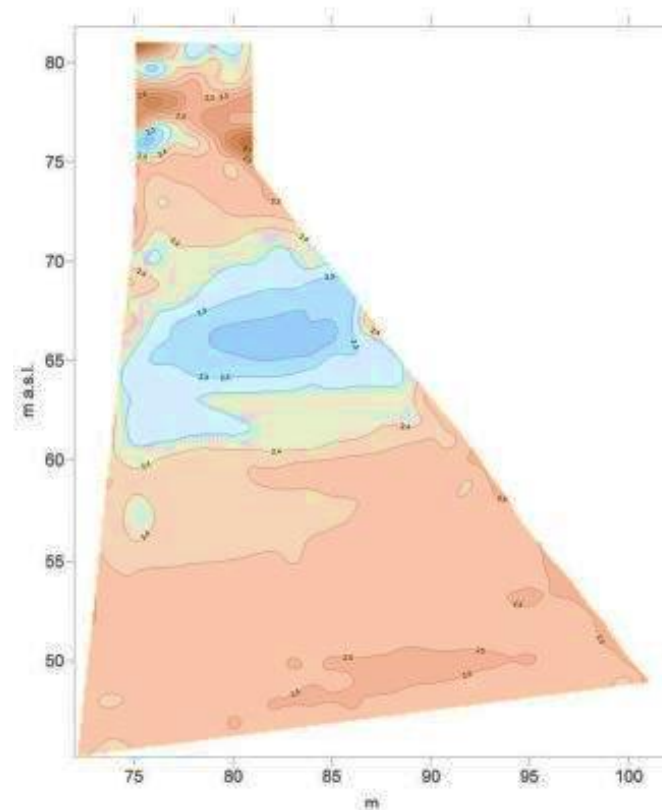

Figure 3-2: Typical Section showing Density Contours in Dam section

### 3.4.2 Geophysical Investigations for Embankment dams for determination of permeable locations/zones

IS:15736 Code of Practice for geological explorations by Geo-Physical Methods (Electrical Resistivity Methods) can be referred to for application of electrical resistivity method.

ERT (Electrical Resistivity Tomography) provides depth and location of anomalous zones based on lowering of resistivity values due to higher water content. Streaming Potential (SP) provides information on the flow of water through saturated zones and helps to differentiate between zones having higher moisture content and zones contributing to seepage.

### 3.4.3 Determination of Site Specific Seismic Parameters

Where this study is required to be conducted, relevant literature will need to be referred to. The report is to be prepared in accordance with the Guidelines for preparation & submission of site specific seismic study report of river valley projects to National Committee on Seismic Design Parameters (NCSDP) prepared by CWC & put up to NCSDP for approval.

This page has been left blank intentionally.

## Chapter 4. MATERIALS FOR REHABILITATION

### 4.1 Introduction

Dam and appurtenant structures are subjected to damages/deterioration owing to various reasons like floods, earthquakes, landslides, ageing etc. Damages occur more frequently on spillway glacis, piers, energy dissipation arrangements etc. If not paid due attention, these structures deteriorate progressively with time there by raising dam safety concerns. It is advised to plan repairs works using repair materials and methodology based on the experience gained with suggested repair/remedial measures in various projects, study of literature available on the subject, internationally adopted repair methodology/systems, relevant BIS codes, ASTM, ACI, European Code's, ICOLD's, etc.

It is imperative to take into account the compatibility of repair material with the parent material and its selection/suitability for specific repair. Repair materials like HPC (High performance concrete), Cementitious mortars, Epoxies etc. have been discussed in detail. Their applications along with advantages and limitations are also brought out.

### 4.2 Methodology for Concrete Repair and Rehabilitation

A basic understanding of causes of damages in structures is essential to perform a successful repair. The following general procedure should be followed for evaluating the condition and repairing the damages in a structure:

- Evaluation of condition of the structure
- Analysis of causes based on the observations made
- Selecting repair materials and methodology

- Preparation of drawings and specifications
- Execution of the repair works.

After completion of the repair work, monitoring shall be carried out for performance evaluation.

#### 4.2.1 Evaluation of Condition (Damages) of Structures

A detailed evaluation of the structure is necessary when a major repair or rehabilitation is required for smooth operation and functioning of the structures. A thorough review of engineering data including design, drawing, construction history, instrumentation data, O&M records and periodical inspection reports is required to understand the current condition.

#### 4.2.2 Condition Survey & Mapping

Various types of concrete deficiencies should be mapped after carrying out a visual inspection and condition survey. Concrete deficiencies may be in the form of the following or in combination thereof.

- Cracking
- Disintegration
- Distortion & Movement
- Spalling
- Delamination
- Seepage
- Joint Sealant Failure
- Erosion

#### 4.2.3 Surface Mapping

It should be carried out along with condition survey. Detailed drawing identifying all the above deficiencies should be prepared. Photographs and video clips also help in

describing the damages. Under water inspections, non-destructive testing may also be carried out as per requirement.

### **4.3 Analysis of causes of distress & deterioration in concrete and their symptoms**

#### **4.3.1 Causes**

It is necessary to establish the cause for the damage that is observed in the concrete to make an intelligent choice concerning selection of repair material & methodology. The causes either isolated or in combination may result in spalling, cracking, corrosion of steel, disintegration, seepage, joint failures, etc.

Some of the causes are given below:

- Accidental loadings
- Acid attack
- Alkali Silica reactions
- Sulphate attack on concrete
- Construction errors
- Differential settlement and movement
- Shrinkage
- Temperature changes
- Cavitation, abrasion and impact
- Freezing and thawing

#### **4.3.2 Symptoms of Distress and Deterioration**

The symptoms of distress and deterioration need to be related to the cause of concrete deterioration. Table 4-1 may be seen in this regard.

#### **4.3.3 Criteria for Selection of Repair Materials & Methodology**

Based on the symptoms observed, the possible causes of damages need to be identified. There after each of the causes should be studied & investigated, as necessary to

zero in to the actual cause of distress. The repair methodology should as far as possible focus on methods to eliminate the cause. Efforts also need to be concentrated on selection of appropriate repair materials which are discussed in the paras below.

### **4.4 Repair Materials & their Suitability**

Following repair materials are discussed in detail:

- High performance concrete (HPC)
- Bonding Agents
- Cementitious Mortar [Based on EN 1504-3 (R4)]
- Free flow Micro-Concrete
- Various Types of Grouts
- Epoxy compounds
- Patching Materials
- Resurfacing Materials
- Steel liner
- Fibre - reinforced concrete
- Polymer concrete and coatings
- Geo-Synthetics & Geo Membrane as sealing system for dams

#### **4.4.1 High Performance Concrete**

High performance concrete is a concrete mixture, which possess high durability and high strength when compared to conventional concrete. This concrete contains additional cementitious materials such as Silica fume and a superplasticizer. The use of these materials enhances the strength, durability and workability considerably. High Performance Concrete can be designed to give optimized performance characteristics for a given set of loads, usage and exposure conditions consistent with the requirements of cost, service life and durability. The high performance concrete does not require spe-



Table 4-1: Causes &amp; Symptoms of Distress

Causes	Symptoms							
	Construction Faults	Cracking	Disintegration	Distortion/movement	Erosion	Joint Failure	Seepage	Spalling
Accidental loadings		√						√
Chemical reactions		√	√				√	
Construction errors	√	√				√	√	√
Corrosion		√						√
Freezing & Thawing		√	√					√
Settlement & Movement		√		√		√		
Shrinkage	√	√		√				
Temperature Changes		√				√		√
Erosion			√		√			

cial ingredients or special equipments but requires proper mix design and production.

High performance concrete (HPC) is designed to provide high erosion resistance in the construction/repair of various hydraulic concrete structures like spillway crest, glacis, energy dissipaters, silt excluder tunnels, tunnel spillways, etc.

It has been observed that the damages in the above structures mainly occur due to abrasion by silt laden water. This can get aggravated by the impact of large sized rolling boulders, where applicable.

Repairs carried out with High Performance concrete/Silica fume concrete has following main advantages:-

- High Compressive strength
- Very low permeability of the concrete
- High resistance to chemical attack.
- High workability and control of slump
- Low water cement ratio

- Low bleeding and low plastic shrinkage

Generally repair work is conducted during lean season. It will be desirable that the works of identification of quarries for fine & coarse aggregates, aggregate sampling & testing and concrete mix design are carried out before award of such repair works to an agency, so that the repair works can be completed in a timely manner during the working season.

The abrasion resistance can be significantly improved by using maximum amount of hardest available coarse aggregates. The aggregate occupy the largest volume in the concrete. The proportioning of it is also very important. It is desirable that the Los Angeles abrasion value, Crushing value and Impact value of aggregate shall be less than 25%. High range water reducing admixture (i.e. super plasticizer) and blending of Silica fume with cement can be used to develop high strength concrete. The cementitious material may vary from 450-500 kg/cum with a w/c ratio of less than 0.3. A compatible super-plasticizer (PCE based) helps in obtaining required slump and workability.

Proper curing is essential to minimize micro cracks. The ingredients of high strength concrete for concrete repair works are given in Table 4-2.

#### 4.4.2 Bonding Agents

These are natural, compounded or synthetic materials often used in repair applications for bonding old concrete with fresh repair

Table 4-2: Ingredients of High Strength Concrete

Ingredient	Code	Important Parameters
Cement	IS:269	53 Grade High strength OPC
Silica Fume (8-10% by wt. of cement)	IS:15388	SiO <sub>2</sub> (Min.% by mass) – 85% Specific Surface(Min.) – 15000sqm/kg
Super Plasticizer	IS:9103	High Range PCE based
Epoxy for Bonding new & old concrete	ASTM C-881 Type-II, Grade-2, Class B+C	Bond strength – 10 MPa (14 days) as per ASTM C 882.
Fine Aggregate	IS:383	
Coarse Aggregate	IS:383	

Epoxy grouted 25 mm diameter L-shaped steel anchors along with epoxy bonding layers between old and new concrete can create the required bond between the old and fresh concrete. The repair methodology is normally based on the depth of damaged concrete. The approach recommended is given in Table 4-3.

Any damages to reinforcement bars are to be repaired/rectified suitably.

The frequency of repairs may vary depending on parameters like annual sediment load, high velocity, hydraulic head, hardness & size of the sediment, rolling boulders etc.

The defect liability and free maintenance period may be included in technical specification for maintaining high quality standards.

concrete or mortar etc. Latex emulsion and epoxies are the two main types of bonding agents in use. However, bonding action of epoxy is considered ideal for repair works of large magnitude because of its excellent bonding characteristics with substrate concrete.

#### 4.4.3 Cementitious Mortar for Structural repair [Based on EN 1504-3 (R4)]

Erosion is often been observed in the concrete of spillway piers. The depth of erosion varies from few to several centimeters causing reduction in the provided cover of concrete or exposure of reinforcement at some places. Generally it is observed that the erosive forces on the piers are relatively less compared to those at glacis of spillway. As piers are structural members transferring the water pressure on gates to the spillway and

Table 4-3: Repair method recommended as per damaged depth of concrete

Damaged Depth	Repair Method
Upto 100 mm	Delay the repair judiciously
Between 100 mm to 500 mm	High Performance concrete (60 MPa or more with MSA of 20 mm)
Greater than 500 mm	500 mm thickness of HPC with standard concrete M25 A20 below

thereafter to the foundation, such damages may become cause of concern from dam safety point of view. Cementitious mortars are preferred because the physical & mechanical properties of these mortars are similar to that of parent concrete. The methodology of repair may vary depending on the depth of erosion. Depth of 12-50 mm may be repaired with High Performance Cementitious Mortar complying with EN: 1504-3 (R4). In such repair, bonding of cementitious mortar with the old concrete is an important concern. As per EN: 1504-3(R4), minimum adhesive bond strength of 2 MPa has been specified. Due to above properties the repaired layer becomes integral part of the structure.

EN: 1504 is a European Standard titled as "Products and systems for the protection and repair of concrete structures – Definitions, requirements, quality control and evaluation of conformity". It covers all stages of the concrete repair process i.e. assessing the initial problem, methods of remediation, recommended site practice and specifications for products to ensure the future integrity of the structure. It consists of 10 parts from EN 1504-1 to EN 1504-10.

European Standard EN: 1504-3: Structural and non-structural repair (mortars) specifies requirements for the identification, performance (including durability) and safety of products and systems to be used for the structural and non-structural repair of concrete structures. This European Standard covers repair mortars and concretes used in conjunction with other products and systems, to restore and/or to replace defective

concrete and to protect reinforcement, necessary to extend the service life of a concrete structure exhibiting deterioration. The fields of application covered in accordance with ENV: 1504-9 are given in Table 4-4.

Technical specifications may be prepared to use this high performance cementitious repair mortar in repair of spillway piers, CFRD, freezing & thawing related damages and other structures.

In the Dam Rehabilitation and Improvement Project (DRIP) it has also been used in masonry dams for re-pointing the damaged pointing on the upstream face to control seepage, as it is UV-resistant and because of compatibility of its thermal properties. Also as its compression strength is high it provides the necessary impermeability.

The initial performance tests on repair products in accordance with Table 3 of EN: 1504-3, which need to be complied for structural repair mortar class R4 are at Table 4-5.

The repair materials/systems shall be CE certified meeting EN: 1504-3 Class R4 categories as per principles 3.1, 3.3, 4.4, 7.1 & 7.2 defined in EN: 1504-9.

The cementitious mortar complying with these properties are prepared using crystal-line technology or polymer based additives in the cement. Epoxies have also been used for repair of piers, however cementitious mortar due to similar physical properties as the parent concrete is being preferred.

Table 4-4: Fields of application in accordance with ENV: 1504-9

Principle	Description	Methods
Principle 3	Concrete restoration	3.1 Hand applied mortar
		3.3 Spraying concrete or mortar
Principle 4	Structural strengthening	4.4 Adding mortar or concrete
Principle 7	Preserving or restoring passivity	7.1 Increasing cover with additional mortar or concrete
		7.2 Replacing contaminated or carbonated concrete

Table 4-5: Performance Requirements as per EN: 1504-3 (R4)

Item No.	Performance Characteristic	Reference substrate (EN 1766)	Test Method	Requirement based on EN:1504-3 (R4)
1.	Compressive strength	None	EN:12190	$\geq 45$ MPa
2.	Chloride ion content	None	EN:1015-17	$\leq 0.05\%$
3.	Adhesive bond	MC(0,40)	EN:1542	$\geq 2.0$ MPa
4.	Carbonation resistance	None	EN:13295	$D_k \leq$ control concrete MC(0,45)
5.	Elastic modulus	None	EN:13412	$\geq 20$ GPa

The cementitious mortar with aforesaid properties can also be used for filling of shallow cavities.

The cementitious mortar shall not be used for repair works above previously applied epoxy surfaces as it can only bond with concrete substrate.

The defect liability and free maintenance period may be mentioned for maintaining high quality standards of repair.

#### 4.4.4 Free Flow Micro Concrete

Free flow micro-concrete is gaining popularity as a repair material because of its multiple advantages. It is a versatile material for repairs of damaged reinforced concrete especially in zones of low accessibility in the structure and where compaction of concrete by vibration is difficult. Micro-concrete usually consists of Portland cement, graded aggregates of less than 10 mm size, fillers and additives to impart strength and non-shrink characteristics. It is usually supplied by vendors in ready to use form and addition of water is only required at site. Usually its 28 days compressive strength is more than 50 MPa.

#### 4.4.5 Various Types of Grouts

Various types of grouts to suit specific application are available. They can be cement/cement-sand grouts, fiber reinforced grouts, expanding grouts, epoxy grouts etc. They provide flowable consistency, which can be pumped into cracks or remote locations of the structure. Grout should remain in position without cracking and should

have negligible shrinkage. Cementitious grouts or cement-sand grouts are sometimes prepared with graded aggregates of less than 5 mm size and admixtures to enhance certain properties. Fiber reinforced grouts, have a higher tensile strength, abrasion resistance and toughness. The percentage of fibers (glass, steel, polypropylene etc.) is usually 1 to 3% by volume. Epoxy grouts because of their low viscosity, negligible shrinkage and excellent bond with almost all construction materials are also widely in use.

#### 4.4.6 Epoxy Compounds

Epoxy compounds are used in the concrete structures due to their various desirable performance characteristics such as adhesion, high compressive & tensile strength, rapid hardening, chemical resistance & moisture resistance. Due to these qualities, epoxy compounds have found wide variety of uses such as sealants, grouts, binders in mortars, bonding agents & patching materials. Epoxy formulations have been developed which will bond to damp concrete and even bond to concrete under water.

The advantages of resin based repair materials are high bond strength, compressive strength and tensile strength. For repair of 6-18 mm thickness, epoxies are considered as one of the alternative in some cases. Epoxies have been used to repair the damages in concrete & steel liner of silt excluder galleries & crack filling. Epoxies can be applied up to a thickness of 18 mm, 3 layers of 6 mm each. Hence they are not suitable for higher depths. However for repairs of deeper cavities, epoxy mortar can be considered.

ASTM C 881 provides the technical specifications for the use of various epoxies in load bearing and non-load bearing for following applications:

- For various grout applications in cracks, foundations & anchoring
- As a binder in epoxy mortar
- As a bonding agent between hardened concrete to fresh concrete

ASTM C-881 is a standard specification for "Epoxy-Resin-Base Bonding Systems for Concrete". This specification covers two-component, epoxy-resin bonding systems for application to Portland-cement concrete, which can cure under humid conditions and bond to damp surfaces. Component A is an epoxy resin with or without reactive diluents. Component B is one or more curing agents, which on mixing with Component A causes the mixture to harden. Suitable inert filler is uniformly incorporated in one or both components as per requirement. The filler is either non-settling or readily dispersible in any component in which it is incorporated. This specification provides for the classification of epoxy-resin bonding systems by type, grade & class.

Type: The bonding system has been distinguished into 7 types depending upon the requirement. Out of these, the 3 types that have been identified for use in repair of hydraulic structures are at Table 4-6.

Grade - Three grades of systems are defined according to their flow characteristics and are distinguished by the viscosity and consistency requirements.

Grade 1 - Low viscosity (0 – 2 Pa.s)

Grade 2 - Medium viscosity (2 Pa.s – 10 Pa.s)

Grade 3 - Non-sagging consistency (0 – 6 mm)

Classes - Classes A, B, and C are defined for Types I through V in accordance with the range of temperatures for which they are suitable (see Table 4-7).

In case class C epoxy is applied at lower temperature, the substrate concrete need to be heated up to 15<sup>0</sup>C or above. Technical specifications need to be prepared for use of epoxy materials as epoxy grouts & epoxy mortars.

- Epoxy grout: The epoxy grout is a 2-components low viscous epoxy resin bonding system (Resin & Hardener) conforming to ASTM C881 Type-IV Class C. Epoxy resins are widely used as grouting materials. The cracks are filled either to seal them from the entrance of moisture or to restore the integrity of structures. Cracks up to 6 mm or less are most effectively filled with pourable or pumpable epoxy compounds whereas epoxy binders mixed with filler are used for wider cracks. Epoxy resins are also used for grouting anchor bolts in the hardened concrete. The Mechanical properties of epoxy resin bonding system (Neat Resin System) is given at Table 4-8.
- Epoxy mortar: The epoxy mortar comprises of epoxy binders and aggregate/filler. Epoxy binder is 2-component epoxy resin bonding sys-

Table 4-6: Three Types of Epoxy and their application

<b>Type I</b>	For use in non-load bearing application for bonding hardened concrete to hardened concrete and other materials, and as a binder in epoxy mortars or epoxy concretes.
<b>Type II</b>	For use in non-load bearing applications for bonding freshly mixed concrete to hardened concrete.
<b>Type IV</b>	For use in load bearing applications for bonding hardened concrete to hardened concrete and other materials and as a binder for epoxy mortars and concretes.



Table 4-7 Classes of epoxy and their use as per range of temperature

Class A	For use below 4 °C, the lowest allowable temperature to be defined by the manufacturer of the product.
Class B	For use between 4 °C and 15 °C.
Class C	For use above 15 °C, the highest allowable temperature to be defined by the manufacturer of the product

Table 4-8: Mechanical properties of epoxy resin bonding system

Sl. No.	Performance Characteristic	Test Method	Requirement
1.	Viscosity of Neat Resin System	ASTM D 1084	< 20 Poise (2.0 Pa.s)
2.	Compressive strength (7days)	ASTM D695	≥70 MPa
3	Tensile strength (7days)	ASTM D638	≥50 MPa
4.	Bond strength (14days)	ASTM C882	≥10 MPa

tem (Resin & Hardener) conforming to ASTM C881 Type-IV Class C.

The mechanical properties of Epoxy binder (Neat Resin System) are given at Table 4-8. Quartz sand/filler material is also used in preparation of mortar as per manufacturer's recommendation. The epoxy mortars are used for patching of repairing surface of concrete structures. The repair of hydraulic structures like silt flushing tunnels and hydraulic tunnels/shafts where continued submersion under water reduces the problems of thermal expansion can also be carried out using suitable under water epoxy mortar. Epoxies have additional advantage of having good adhesion strength with concrete as well as steel liners.

Epoxy can withstand abrasion & cavitation. However, there is wide difference in coefficient of thermal expansion of epoxy and concrete, so fillers such as silica are used to reduce the difference. Thermal stresses at the interface between concrete & epoxy mortar are generated causing peeling off the repaired layer from surface. Decomposition of the epoxies in sunlight due to ultraviolet rays is also reported. These aspects should be taken into account before using epoxy materials. Epoxy is not recommended for

repair in spillway glacis as HPC is considered more suitable. For repair of the spillway piers, cementitious mortars conforming to EN: 1504-3 (R4) are considered to be more suitable.

The defect liability and free maintenance period may be mentioned to motivate the contractor for maintaining high quality standards of repair.

#### 4.4.7 Patching Materials

These are either polymer modified or high strength cement concrete/mortar or pure polymer mortars. They are usually formulated to cope with demands of site conditions coupled with quick repair schedules. Usually use of admixtures and superplasticizers are made to reduce shrinkage and water content. Epoxy and cementitious mortar have been widely used as a patching material because of high strength and good adhesion with substrate concrete.

#### 4.4.8 Resurfacing Materials

Resurfacing materials are basically used to improve wear resistance, chemical resistance and appearance. They produce a finished wearing surface that contains more aggre-

gates and lower paste. Usually cement concrete overlays consisting of low slump dense concrete with super plasticizers, latex modified concrete, fiber reinforced concrete/mortar, silica fume concrete etc., are used as resurfacing materials for repair and rehabilitation purpose.

#### **4.4.9 Steel Liner**

The resistance of steel plates against cavitation and abrasion erosion is well established. However anchoring of new plates with old concrete structure is difficult as any vibrations of the liner plate leads to fracturing and eventual failure. Further cavitation can cause pitting in the steel plates. It is difficult to repair the damaged steel plate due to uneven shape and size. However, if the steel liner is installed properly with stiffeners and anchors during construction stage, it can resist erosion forces effectively. Grouting behind the plates to prevent vibration is recommended.

#### **4.4.10 Fiber Reinforced Concrete**

Typically steel fibre reinforced concrete has less coarse aggregates and contains more paste and mortar to accommodate fibres. This lowers resistance to erosion compared to conventional concrete. HPC blended with steel fibres was used for repair of spillway glacis and bucket of Salal Dam during 1996-97. Later on only HPC has been adopted for repair in Salal dam instead of FRC due to various observations like low workability, no significant increase in abrasion resistance and high cost of steel fibers.

#### **4.4.11 Polymer Concrete and Coatings**

They are of three types viz. Polymer concrete (PC), Polymer modified concrete (PMC) and Polymer impregnated concrete (PIC). PC is formed by polymerizing a monomer binder and aggregates. In PMC, monomer/polymer is added to freshly mixed concrete and cured. In PIC, monomer is impregnated into concrete and sub-

sequently polymerized. Generally polymer concrete has high bond strength and chemical resistance. Being cementitious in nature, they ensure homogeneity in repaired structure.

The types of polymers generally used in modifying mortars and concretes are either thermoplastic or thermosetting resins which can be classified into liquid resins, latexes and water soluble polymers and co-polymers. Selection of a particular type of polymer depends upon the intended use. The way in which nature of polymer system modifies a particular property depends on the type of monomer or resins that constitute the polymer and also on other ingredients added into the system such as surfactants, stabilizing colloids, antifoaming agents etc. The latex admixtures used are styrene butadiene rubber (SBA), polyvinyl acetate (PVA), acrylics or epoxy emulsions. Usually the addition of latex and epoxy to cement mortar makes it more workable and thus facilitates preparation of mortar of low w/c ratio. Curing is essential to prevent cracking.

However, there are difficulties in application as these systems can be hazardous and require care in handling and should be applied by skilled workmen experienced in their use. In addition to above, these materials are quite costly and their performance is yet to be proved in Himalayan Rivers.

Some coatings such neoprene, polyurethane, polyurea can reduce cavitation erosion damage but once there is tear or chip in the coating, the entire coating is soon peeled off.

#### **4.4.12 Geo-Synthetic & Geomembrane as Sealing Systems for Dams**

According to IGS, the International Geosynthetics Society, a geomembrane is “a planar, relatively impermeable, polymeric (synthetic or natural) sheet used in contact with soil/rock and/or any other geotech-

nical material in civil engineering applications”.

Geomembranes are made from relatively thin continuous polymeric sheets, but they can also be made by the impregnation of geotextiles with asphalt or elastomer sprays or as multilayered bitumen geocomposites. These sheets are prefabricated in a factory and transported to the job sites, where placement and field-seaming are performed to complete the job.

Geo-membranes have been used to provide a watertight facing on new RCC dams up to 188 m high, they have been employed for repair of old masonry and concrete dams up to 174 m high, and as impervious components on fill dams up to 198 m high. They have been installed in the dry and underwater. Table 4-9 shows the number of dam in which Geo-Membranes have been installed up to December 31, 2006 (ICOLD Bulletin 135).

Geo-synthetic products have following advantages:

- They are quality controlled and are manufactured in a factory environment with constant parameters.
- They are alternatives to conventional designs by way of replacement of conventional materials and sometimes the only feasible means of construction/repair & rehabilitation.
- They have made previously impossible designs and applications possible.
- They provide better structural quality (prevent deterioration of material, pro-

vide water tightness),

- They can be installed rapidly. They can be easily transported over great distance at relatively low costs.

“ICOLD bulletin 135: Geomembrane sealing systems for dams” deals with the repair and rehabilitation of concrete dams & fill dams and hence may be referred to for rehabilitation of dams with Geo-membrane. The geo-composite mostly used in exposed systems on concrete and masonry dams is PVC. Suggested values for PVC-P geo-composite have been provided at para 5.4 of the ICOLD bulletin no. 135, the same is reproduced for reference (Table 4-10).

In India, Geo-membrane sealing systems have been successfully used in Kadamparai Masonry Dam, Tamil Nadu to reduce seepage.

Under DRIP it is being used in Servalar Dam, Tamil Nadu & proposed to be used in Anathodu Dam, Kerala & Upper Bhavani Dams, Tamil Nadu to arrest seepage through these masonry dams.

#### 4.5 Materials for rehabilitation for bank protection

Following repair materials may be used for repair as bank protection measures and to control scour/erosion problems generally observed.

- Polypropylene rope (PP) Gabions
- Mechanically woven double twisted hexagonal wire mesh Gabions

Table 4-9: Total dams with Geo-membrane

Type of dam	Number of dams	% of total
Fill	183	69.1
Concrete	47	17.7
RCC	34	12.8
Unknown	1	0.4
<b>Total</b>	<b>265</b>	<b>100.0</b>



Table 4-10: PVC-P Geo-composite Performance Requirements

Property	Unit	Test method	2.0 mm + 200 gsm	2.5 mm + 500 gsm
Thickness (Only geomembrane)	mm	EN: 1849-2	2.0 ± 5%	2.5 ± 5%
Geomembrane Tensile strength Strain at break	KN/m %	EN: ISO 527-4	≥20 ≥230	≥28 ≥230
Geotextile Tensile strength Strain at break	KN/m %		≥20 ≥50	≥30 ≥50
Mass per unit area of geotextile	Kg/m <sup>2</sup>	EN: ISO 9864	200±10%	500±10%
Tear strength	N	ISO 34-1 method B without nick Fig.2 of ICOLD Bulletin No.135, speed 50mm/min	≥100	≥ 140
Puncture resistance	Mm	EN: 12691	≥ 1000	≥ 1700
Brittleness at low temperature	°C	EN: 495-5	No failure at -30°C	No failure at -30°C
Hydrostatic pressure resistance	bar	EN: 1928 method B	≥ 10	≥ 10
Dimensional stability	%	EN: 1107-2	≤ 2.5	≤ 2.5
Thermal ageing in water: maximum weight variation after 56 days at 50°C and drying for 24 h at 80°C	%	EN: 14415	≤ 2.0	≤ 2.0
UV radiation resistance : 3000 hours (350 MJ/m <sup>2</sup> )	-	EN: 12224	No cracks	No cracks

- Geo-synthetic materials comprising of geotextiles & geomembrane
- Tetra-pods

Out of the above, Polypropylene rope (PP) gabions and mechanically woven double twisted hexagonal wire mesh are discussed below in detail.

#### 4.5.1 Poly Propylene rope gabions

Polypropylene (PP) rope gabions are prefabricated, flexible & permeable rectangular/cubical collapsible gabions made of polypropylene ropes and usually filled with stones. The PP ropes used for fabrication of gabions are of various diameter, viz. 9mm, 10 mm, 12 mm, 16 mm & 24 mm etc. The ropes are woven in continuous net with aperture size of 100x100 mm or 150x150

mm with or without provision of slings. The gabions are fabricated in various sizes, viz. 1m x 1m x 1m, 2m x 1m x 1m, 3m x 1m x 1m, 4m x 1m x 1m etc.. The PP gabions are available in collapsed form, either folded and bundled or rolled for ease in shipping. Length of the gabion is decided taking into consideration the ease of handling and site conditions. PP gabions shall be adequately stabilized with suitable means for degradation against ultra violet effect.

They can be used while carrying out repairs under water also.

Advantages

- Gabions can be fabricated in various sizes with appropriate rope diameter and aperture dimensions to suit specific site conditions and design requirements.

- Excellent inherent flexibility of the rope and the continuous integral construction imparts excellent flexibility to the gabion, allowing it to adapt itself to uneven surface profiles and to accommodate significant amount of differential settlements and movements while retaining the structural integrity and continuity.
- High resistance to corrosion to the chemical and biological environments which are normally encountered in underwater applications.
- High tensile strength, abrasion strength, thermal stability & excellent durability.
- Ease of Installation as supplied in ready to fill collapsed form. Only the lid needs to be tied at the site after filling. Wherever required, pre-filled gabions can be easily lifted by means of built-in slings with the help of crane and can be placed suitably.

#### Applications

Polypropylene rope gabions may be used to engineer technically sound, cost-effective and easy to implement solutions for a range of problems as under:

- River bank protections – revetment, toe walls, aprons, etc.
- Erosion protection along slopes and embankments,
- Anti erosion structures such as weirs, drop structures and check dams,
- As a low height retaining walls
- Scour protection of hydraulic structures
- Construction of coffer dams for repair works by filling the gabion with bags

filled with clay/sand.

Following physical/mechanical properties of Polypropylene rope gabions are suggested for use in repair works. (Table 4-11)

Note:

Testing for diameter & structure of rope and linear density at Sl. Nos. (4) & (5) respectively shall be carried out as per procedures stipulated in IS: 7071 (Part 1 to 3): Ropes and Cordages – Method of Physical Test.

Breaking strength of rope at Sl. No. (6) shall be determined according to the test procedures as stipulated in IS: 7071 (Part 4): Method of Physical Test for Ropes and Cordages (Breaking Load and elongation at break).

#### 4.5.2 Mechanically Woven Double Twisted Hexagonal Wire Mesh Gabion

Introduction:

Gabions are baskets made of hexagonal /square woven wire mesh. They are filled with boulders at the project site to form flexible, permeable and monolithic structures such as retaining walls, channels and weirs for erosion control projects. In order to reinforce the structure, all mesh panel edges are selvedge with a wire having a greater diameter than the mesh wire.

The wires of gabions are zinc coated. The gabions boxes are supplied in various sizes, 2 m long by 1 m wide by 1 m high being the most popular size.

Table 4-11: Physical/Mechanical properties of Polypropylene ropes

Sl. No.	Properties	Specifications
1.	Material of rope	Polypropylene with adequate UV stabilizer
2.	Mesh opening size	100 mm x 100 mm
3.	Construction of net	Woven joint at the intersection of ropes
4.	Diameter & structure of rope	9 mm dia. 4-strand shroud laid
5.	Linear density of rope	40 ktex (gm/m) with a tolerance of $\pm 8$
6.	Min breaking strength of rope	1550 kg

The boulders to be used for filling the gabion boxes are normally obtained from sources on or near the site and should be durable and of sound quality with wire mesh of size varying from 100 mm to 200 mm.

It may be preferable to use them above water.

Description:

Gabions are rectangular baskets fabricated from a hexagonal/square mesh of heavily galvanized steel wire. The baskets are filled with boulders and stacked on top of one another to form a gravity type wall. Gabions depend mainly on the interlocking of the individual stones and rocks within the wire mesh for internal stability, and their mass or weight to resist hydraulic and earth forces. Gabions are considered to be a flexible structural solution. The material properties and other details shall conform to IS: 16014.

Advantages:

- Ease of handling and transportation
- Speed of construction
- Flexibility (Gabions tolerate movement)
- Permeability to water (Good drainage)
- Gabions offer an easy-to-use method for decreasing water velocity and protecting slopes from erosion.

Applications:

Gabions are used to slow the velocity of concentrated runoff or to stabilize slopes with seepage problems and/or non-cohesive soils. Gabions can be used at soil-water interfaces, where the soil conditions, water turbulence, water velocity, and expected vegetative cover are such that the soil may erode under the design flow conditions.

#### 4.6 Laboratory Studies on Epoxy / Cementitious Repair Materials

There are innumerable systems of different grades of epoxies and curing agents/ hard-

eners with different branded names available in the market. Therefore the selection of epoxy compound/cementitious repair materials for specific applications has to be made by conducting laboratory studies simulating field condition. Laboratory studies therefore form an integral part in determining the suitability of repair material for the particular application. Field tests are also desirable before selection.

After conducting the suitability tests on at least 4 to 5 repair materials, the comparative test results needs to be prepared for taking a final decision.

##### 4.6.1 Mix Viscosity and Pot Life (IS: 9162)

Viscosity is the resistance of the liquid to flow. Individual viscosity of epoxy resins, hardeners and their mix is determined either by Brookfield Viscometer (IS: 9162) or by a flow cup (ASTM) (Figure 4-1 and 4-2).



Figure 4-1: Brookfield Viscometer Ford

The flow cup test is relatively simple in which viscosity (in cps) is determined from the time of efflux of fluid at room tempera-



Figure 4-2: Ford Viscosity Cup

ture. Flow cup, being a handy apparatus, can be conveniently used at site for checking the viscosity. Pot life is the time available for use of epoxy system after its constituents are mixed.

#### 4.6.2 Compressive Strength (IS: 9162)

Generally the unconfined compressive strength of repair materials is determined by subjecting the cube specimens of hardened epoxy/cementitious material of 25 mm size to compression after a curing period of 7 days (Figure 4-3). For repair mortar, 50 mm size cube specimens are normally used for determination of compressive strength (IS: 9162).



Figure 4-3: Compressive strength test of cube specimen

#### 4.6.3 Tensile Strength (IS: 4456, IS: 9162)

The tensile strength test under uniaxial tension on hardened epoxy/cementitious material is conducted on a dumbbell shaped specimen (ASTM D638). However IS: 9162 recommends briquettes shaped specimen for this test (Figure 4-4 and 4-5).

#### 4.6.4 Penetrability

Penetration test involves estimation of pressure and the time required for an epoxy mix of known viscosity to travel through the gap of known width and length. In laboratory, two concrete beams either of size 150 mm x 150 mm x 700 mm or of size 100 mm x 100

mm x 500 mm cast on glass are used (Figure 4-6 and 4-7).

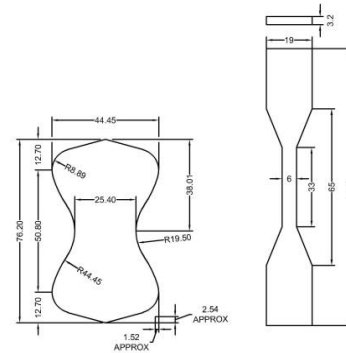

Figure 4-4: Briquette/Dumbbell shaped specimen (All dimensions are in millimetres)

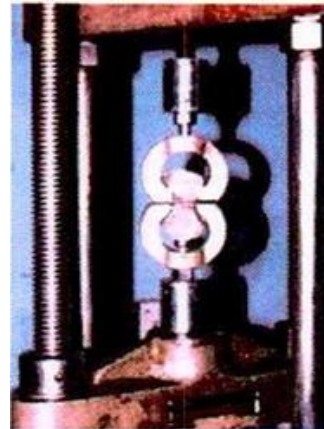

Figure 4-5: Testing of Briquette/Dumbbell shaped specimen in progress

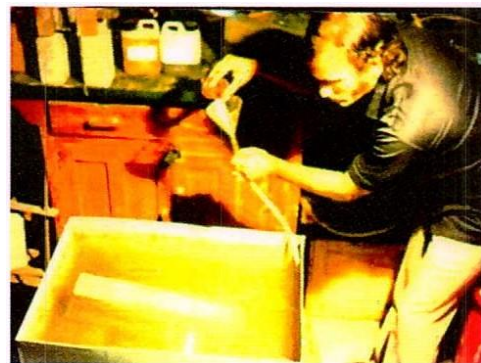
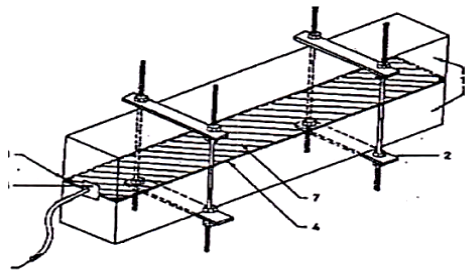

Figure 4-6: Grouting of gap between beams and penetrability test

A gap of required width as per site conditions is created between these two concrete beams using spacers. The gap between the beams is then sealed from both longitudinal sides. The epoxy mix is grouted from one cross sectional side under the permissible pressure as per site condition and the time required for the epoxy mix to travel from





Concrete beam 100mm X 100mm X 500mm  
Clamps  
Spacer  
Crack sealed by epoxy putty  
Grouting ripple  
Grouted epoxy layer

Figure 4-7: Grouting of gap between beams and penetrability test

one end to other is measured. This test serves as guide for judging the time required for grout to travel inside the crack.

#### 4.6.5 Bond Strength under Tension

This test has been devised in CWPRS and is known as Prism test and can be conducted for plain epoxy, epoxy mortar, epoxy concrete and cementitious mortar. A pair of pre-cast concrete prisms of size 71 mm x 71 mm x 125 mm suitably capped in mild steel caps and provided with hooks, are aligned leaving a predetermined gap (representing the cracks size) using suitable spacers between the two near ends. In case of epoxy/cementitious mortar, wider gaps can be kept in between two prisms. For underwater applications, the gap between the prisms is grouted underwater so that the water in the gap is replaced by grout system. The gap is then sealed from all the four sides of the specimen using sealing compound such as epoxy putty. Inlet and outlet nipples are fixed diagonally opposite to each other at bottom and top corners respectively of the test assembly. Once the sealing system is set, the epoxy grout system is injected through the inlet nipple using a small syringe till the flow of grout is seen through the outlet nipple. A gap of 10 to 20 mm is kept between the prisms for testing of repair mortars. After complete filling of the gap with

grout/mortar material, the specimens are then left undisturbed for curing. After completion of a curing period of 7 and 28 days, the inlet nipple, outlet nipple and sealing are removed. The assembly is then fixed with the help of hooks attached to caps in a tensile testing machine and tested to evaluate bond strength of epoxy compound with concrete in direct tension mode (Figure 4-8 and 4-9).

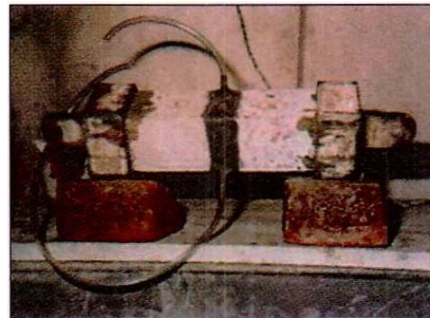

Figure 4-8: Specimen for bond strength

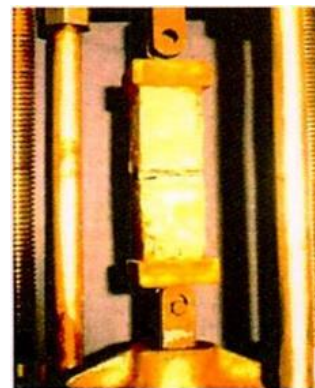

Figure 4-9: Specimen for bond strength test in progress

#### 4.6.6 Bond Strength with Concrete under Shear

This test has also been devised at CWPRS and known as double shear test. The test involves bonding of three concrete cubes of 100 mm size with a total bonding area of 100 cm<sup>2</sup>. Epoxy coat is applied on the prepared bonding surface of all the three concrete cubes. After curing period of 7 days the bond strength of epoxy with concrete is evaluated by holding the assembly (Figure 4-10 and 4-11) in restraining frame and loading the control cube (Middle cube).

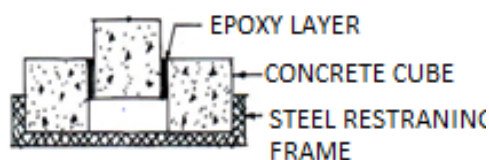

Figure 4-10: Specimen for Double Shear

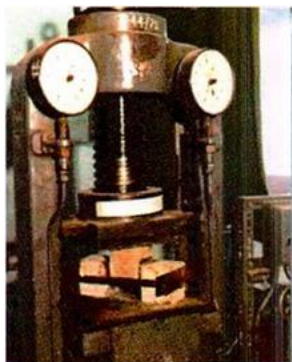

Figure 4-11: Double Shear Strength Test in Progress

#### 4.6.7 Slant Cone Test (ASTM C-882)

The test assembly consists of two equal sections of 76.2 mm x 152.4 mm of cement mortar cylinder. Each section has a diagonally cast bonding area of 9116 mm<sup>2</sup> at a 30° angle with vertical. These two parts are bonded together by repair system under study or by casting a composite cylindrical specimen of size 75 mm dia. x 150 mm height of which, one is pre-cast ordinary concrete portion and other one freshly casted repair mortar material bonded at an angle of 30° through bonding system at the interface of both parts (Figure 4-12 and 4-13). Bond strength is determined by subjecting the bonded specimen to compression after a specified curing period. The test is performed as per ASTM C-882. The test indicates the bond strength under combined effect of compression/shear.

#### 4.6.8 Flexure Test

Concrete beams of size 150 mm x 150 mm x 700 mm are cast with artificially created cracks of various depths and widths at the center of the beam. These cracks are then grouted by epoxy system under study. The



Figure 4-12: Specimen for slant cone



Figure 4-13: Underwater Grouting of Slant Cone

grouted beams and concrete beam of same size without crack are then tested under flexure mode (Figure 4-14) to compare load carrying capacity of the grouted beams.

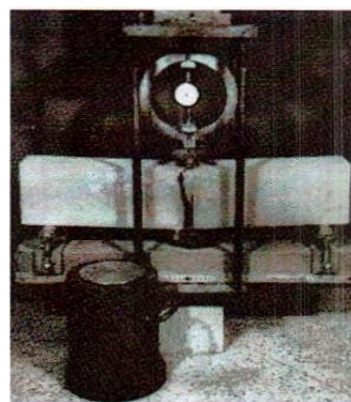

Figure 4-14: Flexure Test in Progress

#### 4.6.9 Pressure Bearing Capacity of the Sealing System

This test is also devised at CWPRS where two cubes of 100 mm side are clamped together with spacers in between to create a gap of required size. One of the cubes is provided with a through hole of 10 mm dia. at centre. The gap surface is then sealed from all the four sides with the sealing system (Figure 4-15) under prevalent site conditions. After a curing period of 7 days, wa-

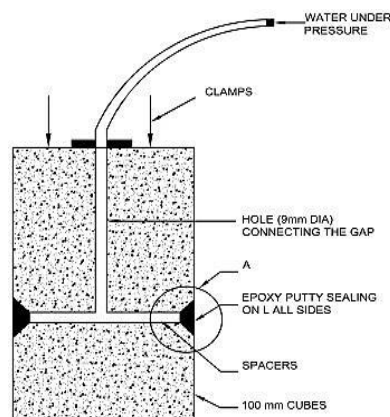

Figure 4-15: Specimen for Pressure Bearing Capacity

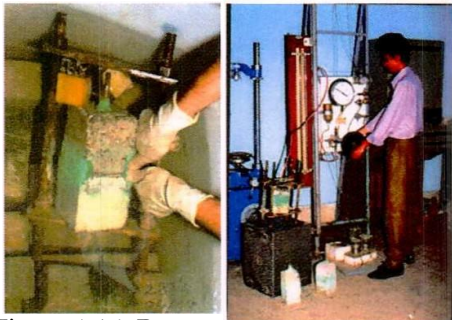

Figure 4-16: Pressure bearing capacity test in progress

ter is injected under pressure in the gap through the hole provided in one of the cubes (Figure 4-16). Water pressure is then gradually increased till failure of the sealing.

#### 4.6.10 Modulus of Elasticity (IS: 9221)

In this test, a cylindrical specimen of hardened epoxy or epoxy/cementitious repair mortar of size 50 mm dia x 100 mm height is subjected to compression by loading it at uniform rate and measuring the deformation/strain (Figure 4-17) as per IS Code for rock samples. The modulus of elasticity is then evaluated from the stress strain curve. In case of epoxy concrete, appropriate size of specimen depending upon the size of aggre-



Figure 4-17: Test setup for modulus of elasticity

gates is taken.

#### 4.6.11 Bond Strength with Steel under Tension

For this test, specimen consisting of two steel plates of 70 mm x 70 mm x 8 mm size welded to form a T assembly is used. Two of such "T" assemblies are then arranged back to back of the flanges, leaving a predetermined gap between them. Plain epoxy/epoxy mortar is filled in the gap. After the specified curing period, the bond plates are pulled apart using tensile testing machine and bond strength is evaluated (Figure 4-18 and 4-19).

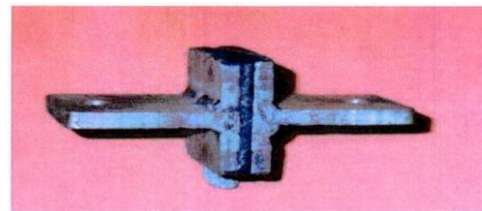

Figure 4-18: Specimen for Bond Strength with steel

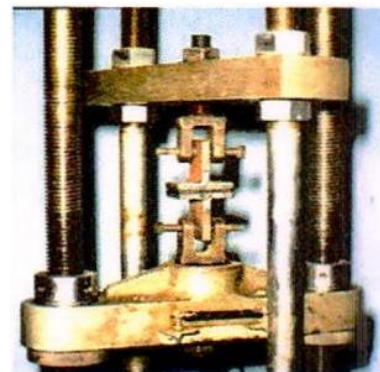

Figure 4-19: Bond Strength with Steel under Tension Test in Progress

#### 4.6.12 Bond Strength with Steel under Shear

This test has also been devised in CWPRS. The specimen consists of four steel plates - two of size 125 mm x 40 mm x 8 mm and other two of size 100 mm x 40 mm x 8 mm. These plates are assembled to form a specimen (Figure 4-20) for double shear test. Plain epoxy/epoxy mortar can be filled between the plates. The bonded specimen is



then tested in double shear mode by pulling the central pair of plates in tensile testing machine to evaluate the bond strength of plain epoxy/epoxy mortar with steel.

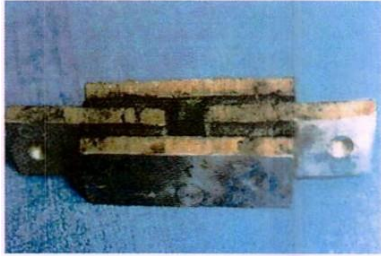

Figure 4-20: Specimen for Bond Strength with steel under shear

#### 4.6.13 Bond Strength with Steel & Concrete under Tension

This test is also devised in CWPRS where a steel plate of thickness 12 mm and of size 50 mm x 50 mm was taken and was provided with a hook at the center to facilitate application of tensile loading. From the cured concrete, prisms of 71 mm x 71 mm x 125 mm size or prisms of size 50 mm x 50 mm x 125 mm were cut. The end faces of the prisms are cleaned using wire brush so as to remove all the loose material and expose the aggregates. The epoxy system is applied over the wet cleaned surfaces of the prism and steel plate. The vertical alignment of the assembly is maintained while bonding (Figure 4-21). The squeezed epoxy from the concrete surface is removed. The bonded specimens are allowed to cure for 7 days at room temperature and are covered with wet gunny bags. After completion of the curing

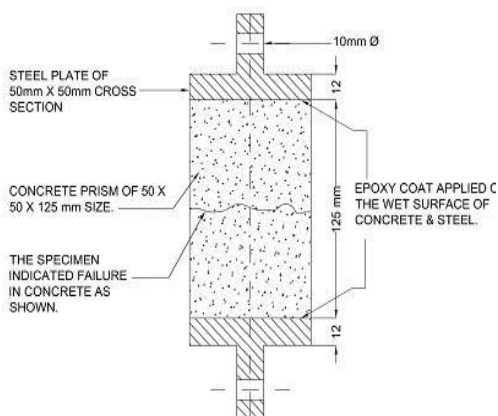

Figure 4-21: Specimen for bond strength with steel and concrete in tension

period, these specimens are tested in Universal Testing Machine under direct tension and bond strength is determined.

#### 4.6.14 Abrasion Resistance of Epoxy Mortar (BS: 812)

To determine the abrasion resistance of epoxy mortar/cementitious repair mortar, specimens are cast with a layer of epoxy mortar/cementitious repair mortar over a 40 mm square concrete piece. After a curing period of 7 and 28 days, the specimens are subjected to abrasion in Dorry's abrasion testing machine (Figure 4-22) using standard sand as an abrasive charge. Abrasion resistance is then evaluated as a loss in weight per unit area. Comparison of the abrasion resistance is made by conducting similar test on a piece of concrete of same size using the same abrasive charge.



Figure 4-22: Dorry's Abrasion Equipment

#### 4.6.15 Flowability / Workability (IS: 2250)

Test for flowability/workability is carried out as per IS: 2250. This property of freshly mixed mortar determines the ease and homogeneity with which it can be mixed, placed, compacted and finished. In this test, mould is placed at the centre of flow table. Then after a layer of repair mortar about 25 mm in thickness is filled in it and the layer tamped 20 times for uniform filling. Afterwards, the remaining portion of the mould is filled with repair mortar and tamped again. After cutting off the excess repair mortar on the top of the mould and cleaning the edge of the mould and flow table, the mould is lifted from the flow table and immediately dropped through a height



of 12.5 mm, 25 times in 15 seconds. The flow is determined as the resulting increase in average base diameter of the mortar mass of Cementitious/Epoxy mortar, measured along four diameters expressed as a percentage of the original base diameter. The percentage increase is expressed in terms of flowability (Figure 4-23).



Figure 4-23: Flow-ability Test in Progress

#### 4.6.16 Assessment of Strength Improvement

In mass concrete structures, compressive strength is the most important property of material in deciding the structural safety. This test method covers the determination of the improvement or reduction of compressive strength for distressed concrete when repaired with epoxy/cementitious mortar after applying a coat of bonding agent. For simulating distressed conditions of the structure and observing improvement/ reduction in the compressive strength of distressed concrete, cylindrical specimens of size 15 cm diameter x 30 cm height are cast using M-20 mixes concrete. After 24 hours, the concrete specimens are removed from the mould and outer surface of specimens is chipped off up to 15-25 mm thickness. After water curing for 28 days, curved surface of specimen is prepared for primer application by cleaning with wire brush followed by water jet cleaning and allowed to dry. After application of bonding system on damaged dry curved surface, the specimen is placed in cylindrical mould of size 15 cm diameter x 30 cm height with the annular portion filled with repair mortar to form composite cylinder of size 15 cm diameter x 30 cm height (Fig 4-24 and 4-25).



Figure 4-24: Chipped off Concrete Cylindrical Specimen



Figure 4-25: Repair Mortar Application on Specimen

Composite cylindrical specimens thus obtained are allowed first to cure with spray water for 3-7 days followed by moist curing. After 28 days curing period, composite cylindrical specimen is tested under uniaxial compression load in the Universal Testing Machine. Similarly, concrete cylinders are also tested for comparing the compressive strength with repaired specimen. The maximum load applied at failure is recorded and compressive strength is calculated by dividing maximum load by contact surface area of the cylindrical specimen. The appearance of composite cylindrical specimen and any unusual features in the type of failure are also noted and failure pattern of both specimens is compared to study the behavior of treated specimen.

## 4.7 Laboratory Experimentation for Selection of Ideal Cementitious Grout System

For assessing suitability of various types of grout mix it is always advisable to check the performance of the grout by conducting various tests in laboratory before conducting trial application of grouting in sample masonry structures.

### 4.7.1 Flowability test by Marsh Cone Apparatus

The test is conducted to assess the ability of the grout mix to spread in dam body. The marsh funnel (Figure 4-26) is a simple device used for measuring viscosity by observing the time in sec. The grout solution contains a mix of cement and fly-ash with admixtures. The funnel is held vertically with the end of the tube closed by finger. The grout system of 945 ml is poured into the cone and the finger is released and flow time of the grout mix is recorded by a stop watch. The flow time goes on reducing at higher w/c ratios. The optimum flow time of more than 30 seconds is suitable for proper spread of grouting in the masonry.

### 4.7.2 Settlement/Segregation Test

The test is conducted to devise the time of grout mix consumption. A properly mixed grout is taken in a measuring cylinder of



Figure 4-26: Flow-ability test by Marsh Cone apparatus in progress

standard size capacity (Preferably 1 liter measuring jar). The stability of the suspension is observed up to a period of 2 hours. For a stable grout mix the difference between water level and settled grouting after 2 hours should be less than 5-7% i.e. less than 70 ml (Figure 4-27).



Figure 4-27: Segregation test set up

### 4.7.3 Gelification Test

This test is conducted to observe the minimum time required for starting setting of grouting. Grout mix is kept in small containers (Figure 4-28) and process of gelification is observed by tilting the small containers to observe the resistance to flow of grout solution. The total quantity of the grout mix should be consumed before on set of gelification process.



Figure 4-28: Gelification Test Set-Up

### 4.7.4 pH Value

For checking the nature of grout solution i.e. acidic/alkaline, pH test is conducted. The value of pH of the grout mix is determined by using a digital pH meter (Figure 4-29). Before determining the pH value, the digital pH meter is calibrated using a standard solution to get proper results. The nature of the grout solution should preferably be maintained alkaline in nature to prevent the acidic attack on the dam body structure.

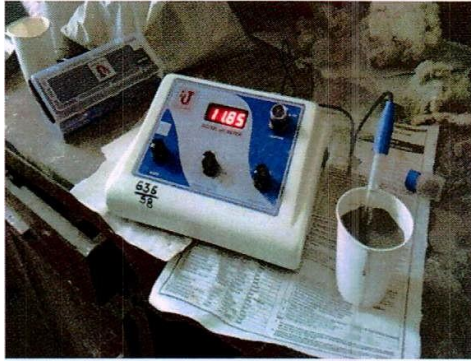

Figure 4-29: pH Value Test Set-Up

#### 4.7.5 Compressive Strength

For qualitative assessment of grout mix, compressive strength is computed by casting cube specimens of size 50 mm/70 mm prepared using grout mix solution at different water cement ratio as per the proportions of grout mix. The cast specimens are demoulded after 24 hours of casting and air cured for a period of 3, 7 & 28 days. After curing, the cube specimens are subjected to loading in a uniaxial compression testing machine. The compressive strength of the specimen is then calculated by dividing the maximum applied load at failure of the specimen during the test by the original cross-sectional area of the cube specimen.

### 4.8 Test on Steel Fiber Reinforced Concrete (SFRC)

Steel fiber reinforced concrete is a composite material made of hydraulic cement, fine and coarse aggregate, and a dispersion of discontinuous, small steel fibers. It may also contain pozzolonas and admixtures commonly used with conventional concrete. In applications where the presence of continuous tensile reinforcement is not essential to the safety and integrity of the structure, such as shotcrete linings, the improvements in flexural strength, impact resistance, toughness, and fatigue performance associated with the fibers can be used to reduce section thickness, improve performance, or both. Steel fibers are available in different sizes, shapes and qualities. Steel fibers have no

significant effect on abrasion resistance of concrete. However, under high velocity flow producing cavitation conditions and large impact forces caused by the debris, SFRC has significantly improved resistance to disintegration.

#### 4.8.1 Toughness Index (ASTM C-1018)

Toughness is a measure of the energy absorption capacity of a material and is used to characterize the material's ability to resist fracture when subjected to static strains or to dynamic or impact loads. The difficulties of conducting direct tension tests on Fiber Reinforced Concrete (FRC) prevent their use in evaluating toughness. Hence, the simpler flexural test is recommended for determining the toughness of FRC. The flexural test simulates the loading conditions for many practical applications of FRC. The flexural toughness and first-crack strength can be evaluated under third point loading using specimens meeting the requirements for thick sections or for thin sections outlined in ASTM C-1018. Specimens should be prepared and tested according to ASTM C-1018 to establish the load-deflection curve. The flexural strength may also be determined from the maximum load reading in this test as an alternative to evaluation in accordance with ASTM C-78. Energy absorbed by the specimen is represented by the area under the complete load-deflection ( $P-d$ ) curve (Figure 4-30). The  $P-d$  curve has been observed to depend on (a) the specimen size (depth, span, and width); (b) the loading configuration (midpoint versus third-point loading); (c) type of control (load, load-point deflection, cross-head displacement, etc.); and (d) the loading rate.

Usually during laboratory testing, it has been observed that the curve is concave upwards to the first crack though there are examples when the curve is convex upwards to the first crack. ASTM C-1018 provides a means for evaluating serviceability-based toughness indexes and the first-crack strength of fiber reinforced concretes. The procedure

involves determining the amount of energy required to deflect the FRC beam a selected multiple of the first crack deflection based on serviceability considerations. This amount of energy is represented by the area under the load-deflection curve up to the specified multiple of the first-crack deflection. The toughness index is calculated

as the area under the P-d diagram up to the prescribed deflection, divided by the area under the P-d diagram up to the first-crack deflection (first-crack toughness) as shown vide Fig.

Indices I-5, I-10, and I-20 at deflections of 3 times, 5.5 times, and 10.5 times the first-

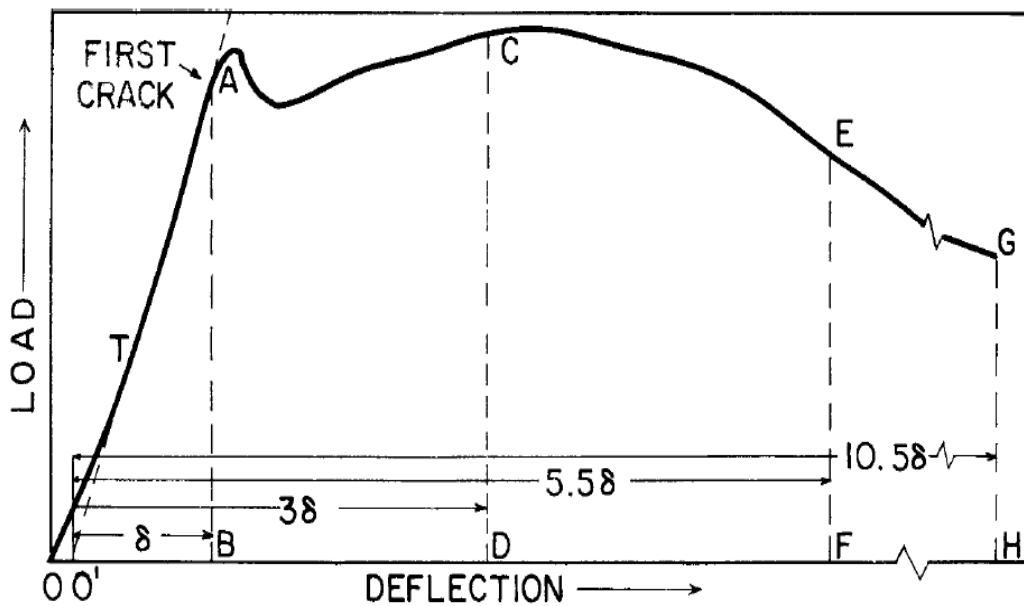

Figure 4-30: Load-Deflection Curve for determination of Toughness Index of FRC (ASTMC 1018)

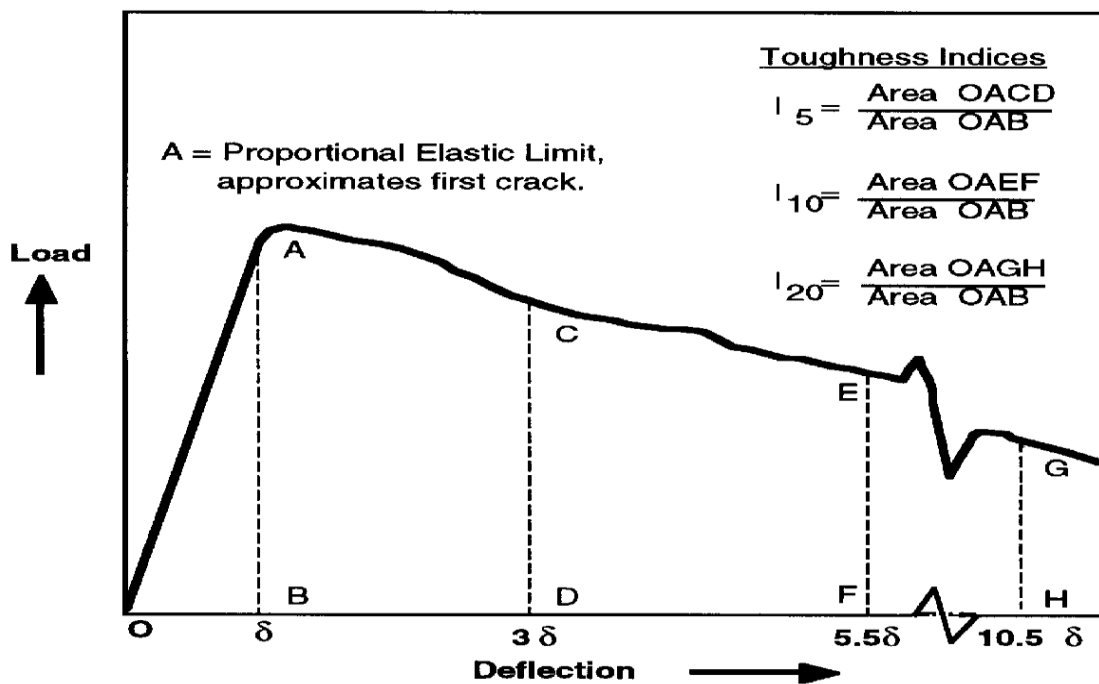

Figure 4-31: Computation of Toughness Index of FRC (ASTMC 1018)



crack deflection( $\delta$ ), respectively, are illustrated vide Figure 4.31. These indexes provide an indication of (a) the relative toughness at these deflections, and (b) the approximate shape of the post-cracking P-d response. The indexes I-5, I-10, and I-20 have a minimum value of 1 (elastic-brittle material behavior) and values of 5, 10, and 20, respectively, for perfectly elastic-plastic behavior (elastic up to first crack, perfectly plastic thereafter) as given below in tabular form (ASTM C 1018).

ASTM C 1018 requires that the first-crack load and the corresponding deflection and toughness be reported in addition to indexes I-5, I-10, and I-20.

Such behaviour is desirable for many applications requiring high toughness and can be reached or exceeded only by careful selection of fibre type, fibre concentration and concrete matrix parameters. The indices have the same meaning regardless of the cross-sectional size and the span of the test specimen. ASTM C-1018 allows extension of the toughness index rationale for calculation of greater indexes, such as I-50 and I-100, to accommodate tougher fiber reinforced composites such as slurry-infiltrated fiber reinforced composites. However, as previously mentioned, it is a measure of the improvement in toughness relative to the unreinforced matrix, while I-5, I-10, and I-20 provide measures relative to a particular fiber mixture's first crack strength.

Casted beams of fiber-reinforced concrete are tested in flexure using the third point

loading arrangement specified in Test Method IS: 516 (Figures. 4-32 and 4-33). Load and beam deflection are monitored



Figure 4-32: Flexure test setup for measuring toughness index



Figure 4-33: Toughness index tested beams

Table 4-12: Value of Toughness Indices

Sl. No.	Area Basis*	Index Designation	Deflection Criterion	Values of Toughness Indices		
				Plain Concrete	Elastic-Plastic Materials	Observed Range for Fibrous Concrete
1.	OACD	I <sub>5</sub>	3 $\delta$	1.0	5.0	1 to 6
2.	OAEF	I <sub>10</sub>	5.5 $\delta$	1.0	10.0	1 to 12
3.	OAGH	I <sub>20</sub>	10.5 $\delta$	1.0	20.0	1 to 25

\* Indices calculated by dividing this area by the area to the first crack OAB.

either continuously by means of LVDT, or by means of mechanical/digital dial Gauges read at sufficiently frequent intervals to ensure accurate reproduction of the load-deflection curve. A point termed first crack which corresponds approximately to the onset of cracking in the concrete matrix is identified on the load deflection curve. The first-crack load and deflection are used to determine the first-crack flexural strength and to establish end-point deflections for toughness calculations. Computations of toughness and toughness indices are based on areas under the load-deflection curve up to the first-crack deflection and up to the specified end-point deflection. Values of toughness indices, residual strength factors, and first-crack strength are obtained using the beam specimens of size 500 mm x 100 mm x 100 mm. Measuring devices are located in such a manner that ensures accurate determination of the net deflection at the mid-span exclusive of any effects due to seating or twisting of the specimen on its supports. Two transducers/digital devices mounted on the jig at mid-span, one on each side, measure deflection through contact with appropriate brackets attached to the specimen. The average of the measurements represents net mid-span deflection.

#### **4.9 Precautions to be observed during use of Repair Materials**

- Epoxy compounds being reactive chemicals, it is necessary to take certain handling precautions such as avoiding skin contact, use of protective masks and gloves and ensuring proper ventilation while conducting tests and also during carrying out actual repair application at site.
- The shelf life of repairs materials, admixtures etc. has to be verified before their application in repairs.
- The grout mixer used for cementitious grouting in masonry dams should have a high mixing speed of

1500 - 2000 RPM to obtain a proper colloidal grout mix.

- The quality control tests for cementitious grouts such as gelification test, flow test, segregation test, compressive strength etc., to assess the quality of the grout mix have to be also conducted during the actual grouting operation at site.

## Chapter 5. REHABILITATION OF CONCRETE AND MASONRY DAMS

Rehabilitation of dams is necessary for two main reasons. First is to counter the effect of the ageing process, which is sometimes aggravated by absence of maintenance. Second is the introduction of new standards as a result of developments in the field with time. For example latest stability criteria against flood and earthquake have resulted in rehabilitation at a large number of dams worldwide, many of which were designed based on the status of art at that time, which has undergone considerable modification subsequently. Also the criteria for consideration of uplift pressures have also witnessed substantial changes. This chapter is divided into three sections: rehabilitation of the foundation, rehabilitation of the dam body, and rehabilitation to improve stability.

### 5.1 Rehabilitation of the Foundation

#### 5.1.1 Loss of strength under permanent or repeated actions

Loss of strength of the rock mass foundations of concrete and masonry dams has been the cause of major incidents. This problem may occur at the beginning of the operation phase or after some years of operation.

The main cause of this scenario is related to alternating stresses in the foundations linked with variations in hydraulic gradient experienced when the reservoir level changes. Thermal effects have negligible impact on the foundation. The alternating stresses may lead to washing away of the joint infillings, foundation deformation, movements of rock joints, and initiation and propagation of cracks.

For concrete and masonry dams the rock mass is usually strong enough to adopt a new equilibrium state after several years of operation. However, sometimes the rock behavior changes due to:-

- *Periodic change of hydraulic gradient*  
Permanent deformation accumulates with time or may occur suddenly after an extended period of stable behavior. This irreversible phenomenon is often associated with a high fluctuating hydraulic gradient. Such conditions may cause significant joint movements and the washing out of the joint fillings and may cause permanent deformation of the dam foundation, or an increase in the amplitude of the reversible movements.
- *Long-term raising of the groundwater table adjacent to banks and foundation.*  
In porous limestone or sandstone foundations, filling of the reservoir raises the groundwater level in the reservoir banks and around the dam foundation. The new water level may modify the equilibrium of the rock mass, depending on the nature and geometry of faults and joints.
- *Chemical and physical alteration of rocks*  
Chemical and physical alteration of rocks may occur under the new conditions induced by the reservoir and this may lead to weakening of the rock, piping or subsidence.

Usually the loss of strength of the foundation occurs over a long period. Therefore, monitoring is necessary. Three measurements are important: seepage, uplift pressure, and inelastic foundation displacements.

Seepage measurement comprises the observation of quantity, origin and quality of seepage, particularly the existence of solids in the water. The source/origin of these solids (if any) needs to be found. Water Quality testing can be useful. The majority of the foundation area needs to be included in the monitoring.

Uplift pressure is measured at distinct points using piezometers. These must be reliable and stable over the long term. The type of the uplift measuring device depends upon the situation. If simplicity and long service life are important, one should select simple stand pipes. On the other hand where access is limited, automatic data collection using piezometers may be appropriate, provided they remain in working condition.

Loss of strength of a rock foundation is often accompanied by displacements, both elastic and plastic. This can be observed more easily in the dam than in the foundation. Useful observations can be made by geodetic survey, by pendulum or by inverted pendulum anchored deep below the dam.

A rapid response is needed particularly when unusually large irreversible displacements are observed. As a first step, the lowering of reservoir water level may be considered.

The problem will also need to be deliberated by experts.

The foundation rock may be strengthened by grouting. The uplift situation may be improved by a combination of grouting and drainage measures.

A case history of Venda Nova dam, Portugal is given below:-

Venda Nova arch-gravity dam, 100 m high, was built in 11951 on the Rabago River in Portugal (ICOLD 1994, Pedro et al 1998). The foundation is mainly granite, with schistose rocks occurring on the right bank at higher elevations. The rock mass is crossed by several sets of joints and local faults, generally clay and mylonite-filled. The initial treatment of this dam consisted of consolidation grouting at the dam-foundation interface, and a vertical grout curtain, down to a

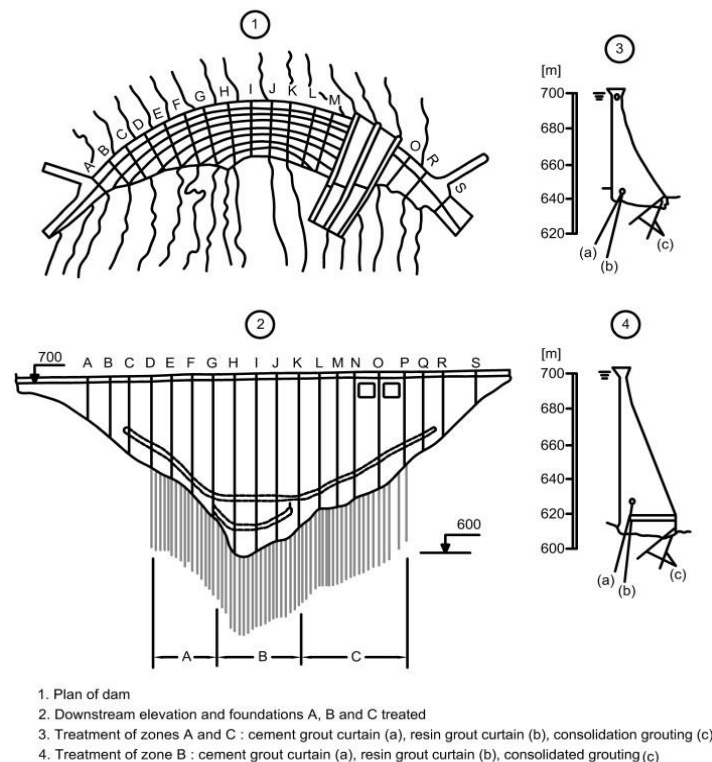

Figure 5-1: Venda Nova Arch Gravity Dam, Portugal



depth of 50 m. Heavy seepage of water was noticed after the first filling of the reservoir, which remained after the initial operation phase. Therefore further foundation treatment was carried out, similar to the initial treatment, and a drainage system installed in 1964.

A monitoring system installed in the dam showed the seepage remaining and the uplift pressure increasing. This was due to the opening of faults and sub-horizontal joints at the left bank and valley bottom. It was accompanied by washing out and the dissolution of filling materials. The dissolved salts in the reservoir were up to 22 mg/l, while the seepage water contained much more than this.

Repair work was carried out in two phases in 1984-85 to improve the hydraulic behavior of the foundation (see Figure 5-1). This aimed at improving the strength and water tightness at the lower zone of the foundation rock mass. In the first phase an upstream grout curtain was constructed with blast furnace cement up to a depth of 25 m. This was intended to create a barrier to allow the more efficient injection of a resin grout curtain in the second phase. At the same time the rock mass was consolidated in the downstream zone of the foundation down to a depth of about 15 m.

The second phase grout curtain was injected with an acrylic resin. This resin was easy to inject owing to its low viscosity before the polymerization reaction begins, and proved an appropriate material to fill joints and cracks, owing to its high ductility and swelling in presence of water after polymeriza-

tion. About 64000 liters of acrylic resin were used in 2755 m of drill holes.

The rehabilitation work was effective in reducing the seepage and the uplift in the foundation significantly. The maximum seepage was 1046 liter/m before the repairs and 12 litre/m after rehabilitation. The maximum uplift pressure was reduced by factor 4 to 5.

### 5.1.2 Erosion and Solution

Foundation erosion can occur due to dissolution and piping in faults & shear zones present in rock foundation, soluble rocks, soil foundations etc. This scenario is often associated with the foundation weakness referred to in earlier section.

The flow of water in erodible or fractured rock can lead to increasing leakage from the reservoir. Even when the foundation rock mass itself is not soluble, but contains faults, shear zones or joints filled with fine-grained loam or clay, erosion can be expected under a high hydraulic gradient. More dangerous for the dam are solution processes within the dam foundation, which can continue by attacking the rock mass itself. Large caverns may be the result. In extreme situations the dam may have to be abandoned. But even when the effects can be controlled, extensive rehabilitation work may still be required.

Seepage measurements and the measurement of uplift pressure during operation, as described in earlier section, will help to detect such developments.

Table 5-1: Useful co-relation between the observed trends in seepage and in piezo-metric pressure.

	Seepage increasing	Seepage decreasing
<b>Piezo-metric head increasing</b>	<b>Unfavorable situation:</b> Rehabilitation may be necessary urgently.	<b>Unfavorable situation:</b> It may be necessary to clean or enlarge the drains.
<b>Piezo-metric head decreasing</b>	<b>Surveillance required:</b> Risk of internal erosion, hence advisable to check whether there are fine materials in the seepage water.	<b>Safe situation:</b> No action necessary.

Table 5-1 shows a useful correlation between the observed trends in seepage and in piezo-metric pressure. When both are rising it is advisable to review the situation and where both are falling, stability is improving.

The choice of the most suitable remedial measures depends upon the nature of the problem. Cavities may be grouted/backfilled with concrete where accessible. The width of the cavities and the volume of the region to be rehabilitated will determine whether concrete, mortar, cement suspensions or chemical grouting material should be used.

More problematic is increasing seepage caused by solution processes. One must anticipate that the rehabilitation work with grouting will only have a limited lifetime. In addition to closing the seepage paths as perfectly as practicable it will be necessary to study whether it is possible to reduce high hydraulic gradients. Such measures are also valuable when erosion of joint infillings, materials contained in faults, shear zones etc. is expected or observed.

### **5.1.3 Grout Curtains and Foundation Drains**

Curtain Grouting is the most commonly used method to control seepage from foundation in concrete/masonry dams. Many old masonry dams have usually been constructed without a grout curtain. Grout curtains are intended to reduce the seepage through discontinuities in the foundation rock. Cement is the most common grouting material, its properties often being improved by mineral additives including bentonite, fly ash, Pozzolana, and granulated ground blast furnace slag. Grouts of silicates and acrylic resins have also been used. Foundation Drainage systems include foundation drainage holes drilled through foundation galleries in the dam and tunnels in the rock mass. In smaller structures, the drainage has also been provided through horizontal channels at the foundation interface.

Degradation of grout curtains and drainage systems may be accelerated under repeated loading cycles or when erosion or solution of the foundation occurs. Grout curtains may also deteriorate with time if they are inadequately designed and constructed. The foundation drainage holes can get choked.

Deterioration in grout curtains can be detected by monitoring the amount and turbidity of seepage water. There have been only a few reported cases of uplift pressure distribution being changed by the deterioration of grout curtains, although the deterioration of foundation drains increase the uplift pressures. Deterioration of grout curtains may occur slowly or suddenly. Slow deterioration may result from micro-ruptures, erosion or solution processes. Such events cannot be detected by a short inspection of the dam. Many years of seepage observations must be reviewed, together with observations of the water level in the reservoir, precipitation, and temperature.

When the grout curtain deteriorates suddenly, and the seepage volume grows quickly, more severe cracks may be expected demanding a quick response. The stability of the dam may need to be assessed.

The deterioration of foundation drainage systems in dams may become apparent when for no other reason, the seepage volume decreases, usually slowly. This is often accompanied by an increase in the uplift pressure near the drains. Sometimes, a choked foundation drains can cause a change in the flow regime, causing gallery walls that have been dry for years or decades, to become wet. Other drains in the vicinity may show increased discharges.

Long-term monitoring results of seepage and uplift pressure, starting from the first impoundment of the dam, should be studied to evaluate the status of grout curtains & foundation drains.

In many dams under the Dam Rehabilitation and Improvement Project (DRIP), additional foundation grouting is being proposed & choked foundation drainage holes have been reamed/re-drilled.

## 5.2 Rehabilitation of the dam body

### 5.2.1 Chemical reactions resulting in swelling

The Building Research Establishment (BRE) notes that two processes control the swelling of concrete dams (BRE 1988). These are an alkali-silica reaction (ASR) and the action of sulfates on concrete and mortar. Swelling in dams is detected by measurement of strain and displacement over time, and by the malfunction of electrical and mechanical equipments like gates in the dam. The effect of the swelling may not be uniformly distributed. The strength and integrity of the affected concrete are reduced by ASR (Sims 1991, Froehlich et al. 2017).

Alkali-Aggregate reaction depends on the nature of the cement and aggregate in the concrete. It requires an ample supply of water. The cycles of saturation and drying of concrete are also thought to be an important factor. In an unconfined or only partially confined locations aggregates are compressed due to swelling and the cement paste around the swelling region is radially tensioned. As a result cracking occurs, relieving the swelling-induced stresses.

The swelling resulting from the reaction varies throughout the dam body and is influenced by the confinement experienced by the structure. This confinement leads to compressive stresses and can reduce or even stop swelling in the confined directions. The swelling is usually confined along the horizontal axis of the dam. Strains of up to about  $10^{-4}$ /year are reported, raising the dam crest by the order of several mm/year (Sims et al, 1988).

Sulphate action occurs due to magnesium (in seawater), sodium or calcium sulphate. It may also result from the oxidation of iron sulphide (pyrite) contained in some aggregates.

Displacements, strain measurements and observations of cracking can assist in detection of swelling and Alkali-Aggregate Reaction in dams. Malfunction of Electrical and Mechanical Equipment like Gates in dams is often experienced as the clearances/ dimensions reduce. The pattern of cracking, microscopic examination/testing can be used to confirm existence of Alkali-Aggregate Reaction in concrete.

In Gravity dams the upstream face of the dam will be the most affected. A general deformation upward and downstream will develop. As the swelling process is not uniform over the whole cross-section, a stress field will result in which compressive stresses occur in the swelling regions and tensile stresses in the adjacent parts. This may lead to cracking at the upstream face, entry of water in the dam body and an increase in uplift.

No effective remedial measure against swelling caused by alkali-aggregate reaction is known. Attempts have been made to protect the vulnerable concrete from the effect of water by the use of coatings and by installing on the upstream face a drained PVC geomembrane system, but it is too early to say whether such attempts have been successful. Mitigation of the effects of swelling has been tried by several methods.

- Cutting slots to relieve the stress caused by the expansive reaction
- Reinforcement or post-stressing in an attempt to reduce the deformation
- Additional weight has been used to reduce the stress in the concrete so as to allow it to operate at a lower stress level, although no evidence has been found to show that this is a successful technique

- Waterproofing the upstream face of the dam to prevent direct contact of dam with reservoir water
- Confine the concrete in critical zones to isolate the effect
- Break out the damaged materials and replacing them by mortar
- Grouting of the dam periodically with special chemicals.

A case history of Chambon dam, France (Bister et al, 1991 & Taddei et al, 1996) is given below:

Chambon Dam (France) is a concrete gravity dam curved in plan, 90 m high and 300 m long. It was completed in 1934 and modified in 1992. The dam was affected by ASR swelling which led to progressive cracking and irreversible strains. The swelling had the effect of producing a 120 mm deformation upstream and an increase in height of 70 mm over 25 years. Initially grouting was carried out and upstream impermeable membrane was installed to reduce the volume of water feeding the reaction. Since the same was not successful the membrane was

removed in the work area and the dam was sawed by 11mm wide slots through full width of the dam to relieve the compression within the upper 20 m of the dam and to relieve the left abutment of the heavy thrust of the swelling concrete (See Figure 5-2). The work was done in three years: in 1995 cuts S3 and S6 were made. These are 21 m in height. Three further cuts have been made in 1996, and three more in 1997. After sawing and before refilling the reservoir, the upstream watertight membrane was re-stored.

Before the work started finite element studies were carried out in order to examine the structure's response during and after the work. In addition pendulums, joint meters, and long base extensometers were used to assess the effect of the sawing on the behavior of the dam. The effects of sawing were monitored on seasonal / annual basis.

Slots were made with sawing machine placed on the downstream face. A sawing cable 11 mm diameter and 68 m long with 40 diamonds per metre was used. High, upstream and downstream pulley blocks, mobile on rack rails were used to make sure

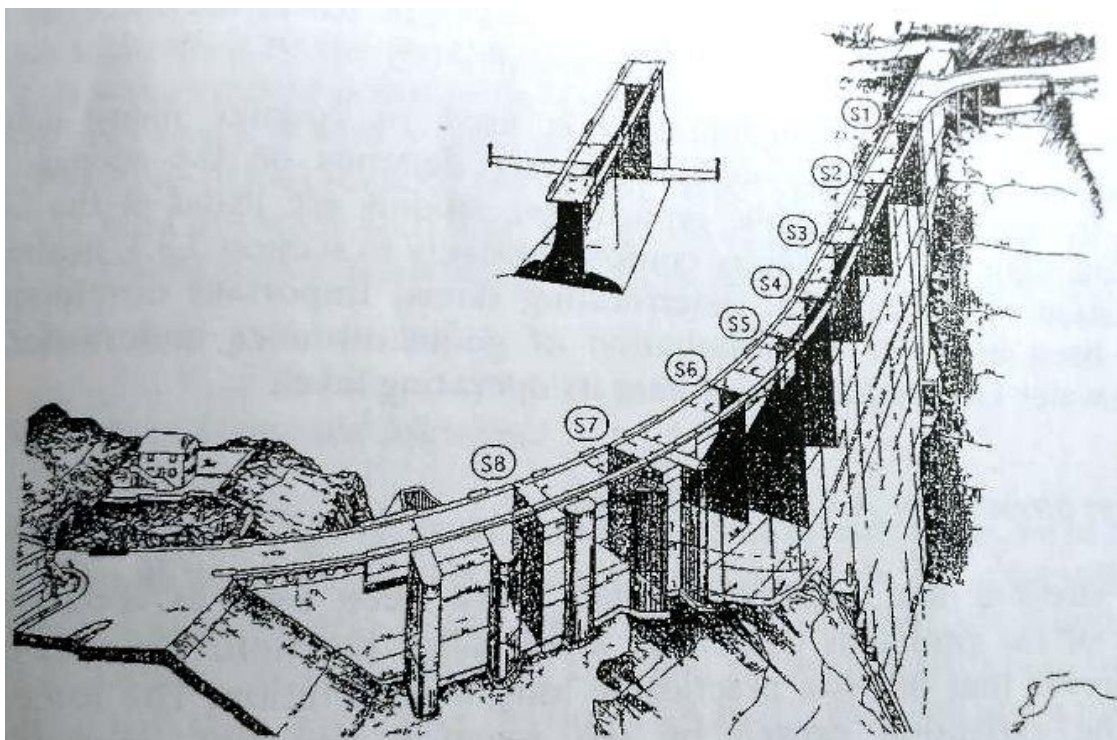

Figure 5-2: Chambon Dam, France - Slot Cuts

that slots were plane and vertical. The average sawing speed was about 2 m<sup>2</sup>/hour. After sawing and before refilling the reservoir it was necessary to restore the upstream watertight membrane in front of each slot.

In 1995 the influence of the saw cuts was detectable at about 60 m or 70 m on each side of the slot. There was a displacement of about 10 mm downstream and the slot, initially 11 mm wide, rapidly closed to about 8 mm and closed completely in a few weeks. During monitoring done in 1996 the influence of the slot was observed at intervals of about 40 m or 50 m and the downstream displacement was 6 mm to 8 mm. In 1997 the influence of the slot was observed at interval of about 30 m and downstream displacements were 2 mm or 3 mm. Several of the joints or slots are still open showing that decompression of the top of the dam has been achieved.

The works were effective in relieving the dam of the effects of the expansion caused by ASR. The dam owner anticipates that in 5 or 10 years it will be necessary to re-saw the structure. He considers that it will be possible to re-saw the original slots.

In our country the problem of Alkali-Aggregate Reaction has been detected mainly in two dams i.e. in Rihand dam, Uttar Pradesh & Hirakud Dam, Odisha. A management approach has been adopted in both cases & grouting of the cracks with suitable materials is being carried out periodically. In Rihand dam the cracks in the spillway piers were grouted with epoxy. The dam toe power house is also affected as the joint between the main dam & the power house had closed leading to transfer of forces from the dam to the power house. The power house columns in which the reinforcement had snapped were jacketed with steel plates. In Hirakud dam, grouting of the cracks on the upstream face of concrete dam was carried out with special chemicals under water.

## 5.2.2 Deficiencies on account of increased seepage

Seepage can play a significant role to aggravate the deterioration process in dams. Formed/porous drains are provided near the upstream face of the dam to trap the seepage through the dam body and to carry the same to the foundation gallery. Causes of increase in seepage, their monitoring and remedial measures in respect of concrete and masonry dams are deliberated as under:

### 5.2.2.1 Seepage problems in Concrete and Masonry dams

#### (a) Causes of seepage

Seepage normally occur through joints or cracks or voids in the concrete and masonry dams.

The main causes of increase in seepage from dam body are;

- Cracks in concrete
- Open joints in masonry on account of deterioration of upstream pointing, poorly packed mortar between stones etc.
- Poorly constructed lift joints in concrete
- Leaking pipes or conduits
- Broken seals/water stops at transverse contraction joints of dam
- Deteriorated or defective concrete

Evidence of seepage can vary from a moist or wet surface to a concentrated flow of water. The most common indicators of seepage in concrete and masonry dams are;

- Wetness on the downstream face of the dam.
- Wetness in the dam inspection and foundation galleries.
- Staining or build-up of calcinations due to leaching in gallery/downstream face of the dam.

- Water sprouting or oozing out of joints or cracks on the downstream face of the dam.
- Significant flows in the gallery drains, drainage system and formed/porous drains.

Increased seepage can result in an increased rate of deterioration of concrete and mortar, leaching of concrete, loss of mortar and reduced structural strength.

Evidence of increased seepage through the foundation and abutments could also indicate the following conditions;

- Foundation deterioration
- Inadequate grout curtain, Non-functioning foundation drains leading to more seepage from other adjacent drains.
- Open/un-grouted joints or seams in the foundation or abutment material.

This could lead to appearance of;

- Wet areas on the abutments or foundation downstream of the dam.
- Vegetation growth in downstream area of the dam.
- Instruments indicating development of high uplift pressures build up (more than that assumed in design).
- Instability of slopes i.e. slumps or rock slides in the dam abutments.

Potential consequences of seepage through dam/foundation with choked drainage holes could result in increased uplift pressure and differential movement in the dam.

Further excessive seepage can lead to loss of useable reservoir water.

#### b) Monitoring of seepage

The amount of seepage is usually related with the level of the reservoir. Normally as

the reservoir level rises, the seepage flow rate increases.

During inspection, one should monitor the rate and trends of seepage. Previous records of seepage recorded in the dam gallery need to be co-related with the respective reservoir levels to check variation. This can provide information about any significant new seepage, changes in pattern or flow and turbidity in seepage.

Noticing turbidity in seepage flow indicates either erosion of dam material or transport of sediment from the reservoir through open joints in dam body and as such is cause of concern. Each time seepage is measured, clarity of the flow should be observed.

While monitoring seepage, increased flows are not the only the cause of concern. A noticeable decrease in seepage, if from foundation drains, can indicate that drains are blocked. Such blockade can lead to deterioration of the concrete, increased uplift/hydrostatic pressure and potential stability problems.

#### c) Measurements of seepage

There are various ways to measure the seepage flow coming in to the foundation gallery. Some commonly used methods are;

- Use of weirs (V-Notch) installed in the foundation gallery drain at appropriate location (s).
- Using bucket and stopwatch.
- Measurement of volume collected in the sump well in a unit time.

Excessive seepage into or through a concrete dam is a sign of presence of voids/openings in dam body, or that of poor bonding at construction lift surface joints. The location and seepage quantities should be noted. Flow in gallery gutters should be monitored to determine if the seepage is increasing.

### 5.2.2.2 Investigations for seepage

Visual examination is an essential tool by which the site engineer, technician, operator, owner or any other responsible party can ascertain, first hand, indications of excessive seepage, material deterioration which are signs of foundation or structural instability. However, the presence of any of the deficiencies brought out above does not necessarily indicate that there is a dam safety problem. Judgment is required based on an understanding of the deficiency, its cause, the short and long term effects, and how these might endanger the dam. The presence of any deficiency should be documented, and if there is any doubt about its effect on the condition on the dam, further investigation should be recommended.

All exposed surfaces of a concrete or masonry dam including adjacent areas should be examined thoroughly. These areas can be clubbed into the following heads:

a) Abutment and foundation areas.

They are often difficult to inspect. The inspection of the abutments and foundation includes the determination of whether any foundation movements or seepage are occurring. The possibility of piping through shear zones, faults etc. or solutioning in the rock mass at abutment and foundation (if the foundation rock consist of lime stone, gypsum etc.) should be investigated if seepage is present.

b) Upstream and downstream faces of the dam.

They should be examined for indications of distress or signs of movement. Areas of seepage on the downstream face should be investigated to determine the source of the water. The faces of the structure can be examined from the top of the dam, the abutments, and other upstream and downstream observation points. The faces can be examined first

from a distance and then more closely if necessary by the use of movable scaffolding or a cradle suspended from the top of the dam. Indications of deficiencies such as weathering, leaching etc. should be observed on the dam faces (especially d/s face) before they become a dam safety problem.

c) Galleries (including instrumentation and drainage system)

They provide information of the seepage through dam body & foundations as well as any cracking or movement as seen in the galleries. Evidence of a reactive aggregate condition may also be observed on the walls of the gallery. The examination of the foundation and formed/ porous concrete drains may indicate changes in flow and potential dam safety problems by way of increase in uplift pressures. Galleries contain instrumentation pertinent to dam safety such as weirs/V-notches, plumb lines, uplift pressure gauges, foundation movement gauges, etc. The instrument readings should be examined and compared with previous readings to determine if any unsafe changes or trends are occurring.

After general inspection, the following vulnerable issues need specific investigations:

a) The upstream face of the concrete dam may be inspected closely for presence of any cracks or points of distress with the help of hanging cradle from top of the dam or by boat. Where the reservoir cannot be lowered, the condition of the upstream face can be assessed with the help of ROV (Remotely Controlled Vehicle)/divers.

b) The contraction joints of the concrete and masonry dams are provided with water stops/sealing arrangements. It needs to be established that the joint sealing system is intact. This can be judged from the excessive leakage coming from the contraction joint into the



- foundation/inspection gallery of the dam.
- c) The seepage observed in the foundation gallery should be checked for turbidity. In case of turbidity, the material must be analysed and co-related.
- d) Assessment of density/porosity of the concrete or masonry dam and its comparison with original design values. Core sampling and geo-physical methods could be used. Sonic tests are also performed to assess the development of cracks in the dam body.
- e) To check whether the dam body drains /porous drains and foundation drainage holes are operative or not. Status of these drains is to be assessed.
- f) Where excessive seepage is noticed especially in masonry dams, Geophysical investigations may be required to pin point the exact locations of seepage for remedial measures.
- adopted to control the seepage in concrete dams.
- i) After identification of cracks on the upstream face of the dam, the same are to be mapped and filled with cementitious grout material under low pressure. All cavities and honey combed areas appearing on the upstream face of the dam are to be repaired and properly filled with cementitious special mortars.
- ii) Lift joints of the concrete dam are vulnerable locations and paths for seepage. These joints need to be grouted with cementitious material with non-shrink admixtures under controlled pressures from the dam top near the u/s face and/or through directional periphery holes from the inspection and foundation galleries as per the pattern of grouting worked out.
- iii) In case the water stops/sealing arrangement provided in the transverse contraction joints/dam block joints are found to be defective (as seen by seepage from trap drains provided at transverse contraction joints coming into the foundation gallery), special treatment to seal the contraction joint is to be taken. The options of treating the joints are as under

### 5.2.2.3 Remedial measures to minimize seepage

It is imperative to study the complex problem of seepage through dam structures systematically and to carry out the necessary investigations such as geophysical methods, tracer techniques, nuclear logging, dam instrumentation for the same where necessary. The information gathered through these investigations is vital for adopting remedial measures necessary to reduce or prevent seepage effectively and economically. The potential of such methods in seepage analysis in adopting suitable cost-effective control measures for mitigating seepage could be very useful. A scientific approach is needed to be followed judiciously and systematically in practice to accomplish the task of reducing or controlling seepage by adopting proper seepage control measures.

#### a) Concrete Dams:

Following remedial measures could be

- The asphalt seal of the existing water stop system is to be re-drilled to remove the old asphalt and to be filled back with fresh asphalt from bottom to top adopting the proper heating system while pouring the asphalt.
- Reaming of the formed asphalt hole to 150 mm diameter may be carried out from dam top to about one metre below the dam foundation and fill the joint with hydrophilic polyurethane sealant following proper methodology under supervision of an experienced engineer. The hole should be sealed at top. The details are covered in Figure 5-3.



- In case the reservoir could be depleted to the level of dam foundation, the hydrophilic sealant can also be pushed into the contraction joint from the upstream face. The details are indicated in Figure 5-4.
  - In case formed asphalt seal is not existing, a fresh 150 mm diameter hole is to be core drilled along the contraction joint from the dam top to rock foundation at appropriate location just upstream of the formed trap drain, ensuring that the drilled hole is exactly along the contraction joint. Fill the hole with hydrophilic polyurethane sealant following proper methodology and the hole is to be sealed at dam top.
  - The trap drain hole of the existing water stop arrangements can be completely sealed with appropriate sealant or hydrophilic polyurethane sealant from bottom to top of the dam, in case no other option is available.
- iv) If required, grouting of the distressed areas in the dam body identified separately, can be undertaken through directional drill holes with double packers from dam top or from downstream face of the dam.
- v) In case the dam body formed drains are found choked, the same are to be made operative by resorting to reaming of the drains. The top end of the formed drains is to be provided with counter sunk plug at dam top and air plug at the exit end of the drains in the foundation gallery to minimize calcination formation. These provisions are to be made as per IS: 10135 *Code of practice for drainage system for gravity dams, their foundations and abutments*.
- vi) Additional curtain grouting & re-drilling of foundation drain holes may be carried out as required.
- vii) Where both grouting and cleaning of drainage holes is necessary, grouting

works are to be carried out first followed by cleaning/reaming of drainage holes.

**b) Masonry Dams:**

Following remedial measures could be adopted to control seepage through the masonry dams;

- i) The stone masonry joints are the vulnerable zones from where seepage can occur. In masonry dams the mortar of the stone masonry can also develop cracks and can leave the stone surface because of shrinkage/ageing. Sometimes proper packing of mortar in between stones is also not carried out.

Where the pointing on the upstream face of the dam is found defective/removed, re-pointing of the same is necessary to arrest seepage.

After depletion of the reservoir the defective/damaged mortar from all these stone masonry joints on the upstream face of the dam is to be removed and the masonry joints are to be raked to minimum 50mm depth cleaned properly and filled back and pointed with cementitious, non-shrink & UV resistant special mortar as per manufacturer's specifications and methodology.

Deeper cavities found in the masonry joints of the dam on the upstream face need to be filled with rich cement mortar upto a depth of about 30 cm and any cavity beyond that is to be filled with cementitious grout for which nozzles are fixed. Pointing at the surface is to be done after undertaking the above works.

In case the water level of the reservoir cannot be depleted below certain level, treatment/pointing of such areas of masonry joints up to river bed levels may be considered using special mortar suitable for under water application through divers.

It is desirable that pointing of the entire area of the upstream face of the masonry dam is carried out to get desired re-

sults.

- ii) After establishing the status of the Stone masonry structure in respect of porosity in the dam by Geo-physical investigations, the pattern of grouting can be worked out with drill holes from dam top and inclined holes from downstream face of the dam. Dam body grouting is undertaken to cover the weak/porous areas of dam using normal ordinary Portland cement, admixtures under low/appropriate grout pressures depending upon the depth of the stage under grouting.

Necessary water loss tests - both (pre-grouting and post grouting) are to be undertaken, properly recorded and compared. Additional water loss tests are done at random locations in separate holes other than the grouted holes to assess the overall permeability of the dam body.

Details of the grouting equipment, specifications and methodology are given at Annexure-1 at the end of this chapter.

- iii) In case the water stops/sealing arrangement provided in the transverse contraction joints/dam block joints are found to be defective (as seen by seep-

age from trap drains provided at transverse contraction joints coming into the foundation gallery), special treatment to seal the contraction joint is to be taken. The options of treating the joints are as under

- The asphalt seal of the existing water stop system is to be re-drilled to remove the old asphalt and to be filled back with fresh asphalt from bottom to top adopting the proper heating system while pouring the asphalt.
- Reaming of the formed asphalt hole to 150 mm diameter may be carried out from dam top to about one metre below the dam foundation and fill the joint with hydrophilic polyurethane sealant following proper methodology under supervision of an experienced engineer. The hole should be sealed at top. The details are covered in Figure 5-3.
- In case the reservoir could be depleted to the level of dam foundation, the hydrophilic sealant can also be pushed into the contraction joint from the upstream face. The details are indicated in Figure 5-4.

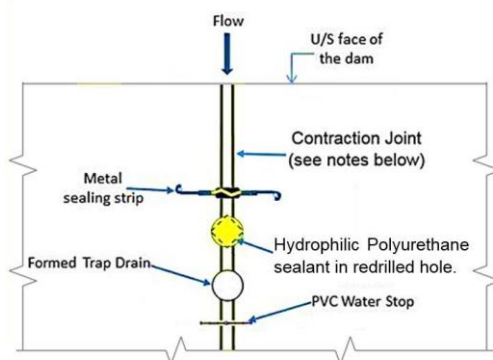

Typical Sketch of water stop arrangement (Designs can vary)

#### Steps for Contraction Joint Remedial Works

1. Material from asphalt seal is removed using auger / drilling.
2. Reaming of the formed asphalt hole to 150 mm dia. from dam top to the foundation of the dam.
3. After washing and drying, fill the hole with hydrophilic polyurethane sealant from bottom of the hole to top of dam.
4. Sealing the hole at dam top.

Notes:

- i) No gap is normally provided in the contraction joints at the time of construction. (Refer IS: 12200)
- ii) Two lines shown for contraction joint are representative of the gap created after contraction of the dam blocks.

Figure 5-3: Treatment of Contraction Joint (Alternative-1)

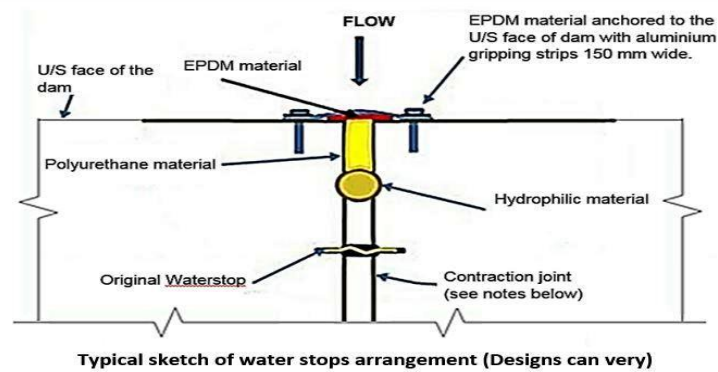

#### Steps for Contraction Joint Remedial Works

1. Raking / Slot cutting of contraction Joints-
  - Joint width: 15 to 50 mm.
  - Depth: 150mm to 200 mm.
2. Insertion of Hydrophilic material - to be pushed into contraction joint from upstream side of dam.
3. Filling of Polyurethane materials.
4. Application of adhesive and EPDM (Geomembrane) material.
5. Fixing of EPDM 150-mm-wide aluminium gripping strips to the dam.

#### Notes:

- i) No gap is normally provided in the contraction joints at the time of construction. (Refer IS: 12200)
- ii) Two lines shown for contraction joint are representative of the gap created after contraction of the dam blocks.

Figure 5-4: Treatment of Contraction Joint (Alternative-2)

- In case formed asphalt seal is not existing, a fresh 150 mm diameter hole is to be core drilled along the contraction joint from the dam top to rock foundation at appropriate location just upstream of the formed trap drain, ensuring that the drilled hole is exactly along the contraction joint. Fill the hole with hydrophilic polyurethane sealant following proper methodology and the hole is to be sealed at dam top.
  - The trap drain hole of the existing water stop arrangements can be completely sealed with appropriate sealant or hydrophilic polyurethane sealant from bottom to top of the dam, in case no other option is available.
- iv) All dam body porous drains, which are found choked, are to be made operative by resorting to reaming of the drains only after completing the dam body grouting where planned. The top end of the formed drains are to be provided with counter sunk plug at dam top and air plug at the exit end of the drains in the foundation gallery to minimize calcination formation. These provisions are to be made as per IS 10135: *Code of practice for drainage system for gravity dams, their foundations and abutments.*
  - v) The stone masonry joints on the downstream face of the dam may be repointed with 1:3 cement mortar, where required.
  - vi) Additional curtain grouting & re-drilling of foundation drains holes may be carried out as required.
- Under the DRIP the following works have been carried out in a number of dams:-
- i) Repointing of u/s face of masonry dam with special cementitious mortar which is UV resistant using anti-shrink admixtures.
  - ii) Grouting of the body of masonry dams using cement mortar with admixtures.
  - iii) Cleaning/reaming/re-drilling of dam body/foundation drainage holes.
  - iv) Grouting of the defective lift joints of concrete dam e.g. Almatti Dam, Karnataka.
  - v) Water stop treatment at contraction joints viz. provision of hydrophilic seals

in Kanhirapuzha dam & Kuttiyadi Irrigation dam.

- vi) Additional curtain grouting in the foundation from the foundation gallery.

### 5.2.3 Shrinkage and Creep Leading to Contraction

Shrinkage and creep need to be monitored closely during the early life of the concrete. Shrinkage is the deformation of concrete associated with the chemical process of setting. Creep tends to be higher if the concrete is loaded soon after setting. Measuring long term displacements using standard survey equipment, plumb-lines, or extensometers is an effective way of detecting these movements. Cracks can be spotted visually. The effect of shrinkage or creep can be severe if accompanied by heavy cracking and potential loss of strength.

The primary method of rehabilitation is to seal the cracks with suitable filler material by grouting under low pressure. However, Vouglans Dam, a 130-meter-high arch dam in France is an interesting example where after investigations and analysis it was found that no rehabilitation work was necessary because the dam had achieved a new position of equilibrium (Bister et al. 1991).

### 5.2.4 Degradation at Dam Faces

Current design practice is to use materials of higher strength near the upstream face of dam because it has long been recognized that the concrete here is vulnerable to deterioration. Four major parameters govern the extent of this degradation:

- The permeability of the dam body, which controls the seepage through it. Further the temperature variations may also cause both cracking and opening of joints, thereby influencing the overall permeability of the structure. The effect of seasonal/daily temperature variation is also covered in 5.2.5.
- The reservoir water may react aggressively with concrete or masonry e.g. acidic water.
- The growth of vegetation in the joints causing physical damage.
- In cold climate by repeated freezing and thawing.

Materials at the dam faces, being in direct contact with the environment are under the aggressive influence of external agents, particularly water at the upstream face and weathering at the downstream face. Skin effects develop, owing to temperature, moisture, frost, snow, ice, wind and rain, as well as chemical reactions with the elements transported by the water. Therefore, in order to prevent the deterioration of the dam materials near the dam faces it has become current practice to use materials of higher strength.

Watertight upstream facings were used in old masonry dams and in concrete dams constructed before the development of mass concrete technology. Typical of these is the Levy type multiple arch concrete structure formed by small arches supported on the upstream face of the dam. Also used were facings of steel, square stone pitching and earth fill, typically the Intel wedge so often found at older European masonry dams. Downstream faces were protected by square stone pitching and by means of earth fill. These facings are not used today and modern facings have since replaced many of them.

As concrete technology improved, it became possible to produce mass concrete watertight and strong enough to dispense with the use of special facings. Thus the use of facings in concrete dams was abandoned, but the practice persisted of using concrete with higher cement content near the upstream face.

Facings of conventional concrete, used also as forms during construction, have been incorporated in RCC dams. Recently some

RCC dams have been designed with a PVC membrane on the upstream face as the sealing element (Giovagnoli et al, 1996).

Deterioration is detected visually or by taking core samples followed by laboratory testing. Remedial works aim either to prevent the access of water into the dam body or to reduce the effect of extreme temperature variations.

Methods now available to reduce percolation through the dam include barrier coatings of a variety of materials like bitumen, mastic asphalt, resins, chemical impregnation of concrete etc. grouting the upstream part of the dam body, and repair of the facing. Experiments at La Girotte dam in France compared the effectiveness of coatings on the upstream face (Bister et al. 1993). This is a concrete multiple arch dam in the French Alps that had been damaged by alternate freezing and thawing and attack by the acidic water. An epoxy coating was found to last between 12 and 15 years before it needed to be renewed. A PVC geomembrane did better than the epoxy, and shotcrete performed poorly.

For all repair methods, it is necessary to empty the reservoir, with a consequent loss of production to the owner. However PVC membranes can be installed underwater thereby avoiding the downtime (Scuero and Vaschetti 1998, Megalamani et al. 2017). The first reported example of such a repair underwater is at the Lost Creek Dam in the United States (Harlan et al. 1998).

In India problem due to acidic water have been faced in the projects in North-East e.g. Myntodu-Lyskha H.E. Project, Meghalaya.

### **5.2.5 Loss of strength because of repeated actions**

Some concrete and masonry dams are unable to withstand the varying loads associated with changes in the reservoir water level and annual/seasonal/daily temperature varia-

tions. These shortcomings may be revealed by cracking. The standard methods of detecting cracks in concrete are used to find this deterioration, including visual observations both above and below water or by drilling and water testing.

The works will include complete mapping of all existing cracks and not only those readily visible from accessible areas viz. the crest, the upstream and downstream faces and galleries. Divers and closed circuit television cameras can inspect and map the cracks in the concrete underwater.

The rehabilitation measures may include:

- a) Strengthening the structure to reduce the stresses in critical locations by:
  - Grouting in joints and cracks after ensuring that they are not widening further based on regular monitoring;
  - Construction of additional buttresses and earth backfilling
  - Providing additional vertical loading through pre-stressed anchors or additional mass.
  - Improvement of drainage.
- b) Reducing the range of temperature variations by:
  - Physical insulation and protection of the faces of gravity dams/spillway by use of reflective paints etc.

In India the problem of cracking due to seasonal temperature variation in being faced in Konar concrete dam of DVC. Details are covered in Appendix-A under case histories.

Remedial works aim to reduce the cause of the cracking by reducing the influence of the fluctuating loading. Insulation is used to reduce temperature fluctuations. Other alternatives may include addition of support through structural re-contouring or added

membranes. Increasing the overall level of compressive stress at critical locations can inhibit the growth of cracks.

### 5.2.6 Structural Joints

These will include both horizontal construction lift joints as well as vertical transverse & longitudinal contraction joints.

Deterioration of horizontal lift joints is marked by a loss of their mechanical and hydraulic properties, particularly the bond, shear strength and the water tightness. This is mainly on account of poor construction. These may need to be grouted to control seepage.

In case of transverse contraction joints there may be failure of water-stops which may lead to increased leakage through these joints. This can be detected from the leakage entering the foundation gallery from the trap drain through the contraction joints. For rehabilitation, additional water seals may need to be provided. For further details 5.2.2 may be referred to.

### 5.2.7 Pre-stressed structures

Although the use of pre-stressing forces in other structures is quite popular these days, it is not much used in dams. The first applications of pre-stressing in dams dates back to the thirties (Monfort et al, 1991). An important benefit of using pre-stressing systems for the rehabilitation of dams is that it is not necessary to empty the reservoir. Pre-stressing systems should be designed conservatively.

Pre-stressing forces are usually applied by tendons or bars, bonded full length or unbonded, and with corrosion protection. The purpose of pre-stressing is to improve the stress distribution at specific zones of the dam body, by countering the tensile stresses developed there. They comprise a system of balanced compressive forces applied at the anchor heads and distributed along the full

length of the tendons. Because of this, the application of pre-stressing force together with grouting may also improve the dam water tightness.

Typical applications of pre-stressing forces in dams are as follows:

- To increase the compressive stress at horizontal sections of gravity dams, particularly at the dam-foundation interface. The need for such an increase may be associated with the raising of the dam, the deterioration of the materials or because of changes in design practices/standards.
- To compensate for the tensile stresses developed next to the points of application of large concentrated forces, such as those near the trunnion bearings of large radial gates.

The typical deterioration scenario of pre-stressed structures is the loss of the pre-stressing force due to creep of the steel, dam materials as well as deterioration of the tendons or bars. The main cause of deterioration is corrosion of the steel elements of pre-stressing devices, particularly those under tension in saturated environment. Monitoring the pre-stressing force is necessary and care is taken to give routine access to the heads. Load cells are often used. This has been done at two concrete gravity dams; Stave Falls and Cova do Viriato (Brigthon and Lampa 1991). Loss of pre-stress load may be shown by increasing deformations of the dam and cracking adjacent to the pre-stressed zone.

An example of old rehabilitation works with pre-stressing include Cheurfas Dam in Algeria, a masonry structure rehabilitated in 1936 using 37 tendons of 10000 KN (1000 t) capacity each (Mohamed et. al. 1969).

More recent examples of the application of pre-stressing forces, particularly for the re-

habilitation and raising of dams are presented below:

Stave Falls and Cova do Viriato are both concrete gravity dams, the first completed in 1911 and rehabilitated in 1985, and the second completed in 1962 and raised ten years later. At Stave Falls dam, load cells were installed in some anchor heads and arrangements were made to facilitate the inspection and the re-tensioning of the tendons, should this become necessary (Brighton et al, 1991).

Auberives (La Bourne) masonry gravity dam, completed in 1878 and rehabilitated in 1984, was rehabilitated by adding tendons of 500 kN capacity, at 2 m centres along the dam crest. The anchor heads were incorporated within a reinforced concrete beam, shaped as a spillway crest, which also improved the discharge of the flow over the dam (Lino et al, 1991).

Fratel Dam, completed in 1973, illustrates the application of pre-stressing forces to improve the stress distribution in the piers supporting the thrusts of high sector gates. Fourteen tendons each of 500 KN capacity were used to pre-stress the blocks with the anchor heads against the pier. The monitoring and the periodic inspections of the dam have confirmed that the behavior is satisfactory (Umana et al, 1973).

### 5.3 Improvement in Stability

Uplift is a significant force in the design of dams. It was not until the 1960s that the foundations under gravity dams were routinely and systematically drained to control uplift (Sims, 1994).

The stability of older dams must be judged based on in-situ investigations. Rehabilitation is expensive, and it is important to take full account of the strength of the dam and its foundations.

Stability of a gravity dam can be improved by the following methods:-

- (i) By enlarging the dam section with provision of buttresses or a continuous backing of concrete/masonry on the downstream face.
- (ii) By adding mass at the dam top.
- (iii) By pre-stressing anchors.
- (iv) By draining the dam & its foundation to reduce uplift by construction of galleries, where not provided.

Particularly in countries where earthquakes were considered as occurring with negligible frequency, it is becoming routine to review the design of older dams from the point of view of their resistance to seismic loading (BRE 1991, ICOLD 2011a).

In Germany dam safety regulations were tightened, prohibiting tensile stress at the upstream toe of gravity dams for the normal operating conditions. The response to this has been innovative work in the construction of drainage galleries in existing dams at the junction with the foundations under full reservoir (Wittke and Greb 1994) which were initially constructed without any foundation gallery. Considerable skill was exhibited in the use of a tunnel boring machine at Ennepe Dam to excavate a gallery within 3 meters of the reservoir face (Ribler and Heitefuss 1999). The work was carried out without emptying the reservoir, giving a significant benefit to the owner.

In India for strengthening of Gravity dams the following methods have been generally considered:-

- i. Pre-stressing
- ii. Earth backing
- iii. Masonry/Concrete backing (either with continuous masonry/concrete backing or with buttresses)

Pre-stressing is considered as an emergency measure, as there is apprehension of loss of

pre-stress over a period of time. Such a situation arose in case of Bhandardara dam, wherein permanent measures such as by way of buttressing was taken subsequently. While studying the alternate of pre-stressing for strengthening of some dams, it is found that to counteract the tension developed under earthquake loading condition, very close spacing of cable is required. Pre-stressing towards heel includes tension at the downstream toe at low water levels.

In case of downstream earth backing, there is apprehension that separation between earth and masonry can occur during earthquake, particularly near the top.

Therefore normally the feasible alternatives for strengthening have been provision of buttresses or full masonry/concrete backing. Gravity dams strengthened for earthquake loading condition are either by way of buttressing or full d/s backing. The performance of these dams so far is excellent. This measure has proved most effective and hence is generally recommended as a safe strengthening measure.

### 5.3.1 Design Aspects

Water level in the reservoir at which concrete/masonry backing and the old masonry/concrete of the existing are to be bonded or joined has an important bearing on the distribution or sharing of the load by old masonry/concrete and backing masonry/concrete. The stresses corresponding to the depth of water at which bonding is done are assumed to be taken solely by the old dam. Subsequent increase or decrease in the stresses is shared jointly by the composite section. The stresses can change due to variation in reservoir level. A high bonding level allows greater flexibility in construction program but increases the backing required resulting in higher cost. Lower bonding levels place severe constraints on the time available for construction but lead to greater sharing of the load by the backing section enabling adoption of reduced sections and consequent economy.

Reservoir level at the time of bonding an existing dam with backing masonry has an appreciable effect on the locked up stresses. This has an effect on the downstream batter of the add-on masonry. Higher the reservoir level at which bonding is done, flatter will be the batter. Thus to achieve economy it is desirable to have reservoir level as low as possible at the time of bonding. The bond level also depends on the availability of time for strengthening works.

Usually the total length of buttresses is not less than half the length of dam for which strengthening is required.

While joining/bonding the old dam with the downstream buttress/continuous concrete or masonry backing, all needful precaution's like roughening the old dam surface, surface preparation/cleaning, provision of shear keys, drainage etc. are required to be taken (Figure 5-5, 5-6 & 5-7).

Under the DRIP two Masonry dams viz. Pechiparai Dam in Tamil Nadu & Kuttiyadi Irrigation project in Kerala are being strengthened from stability considerations, mainly for seismic condition.



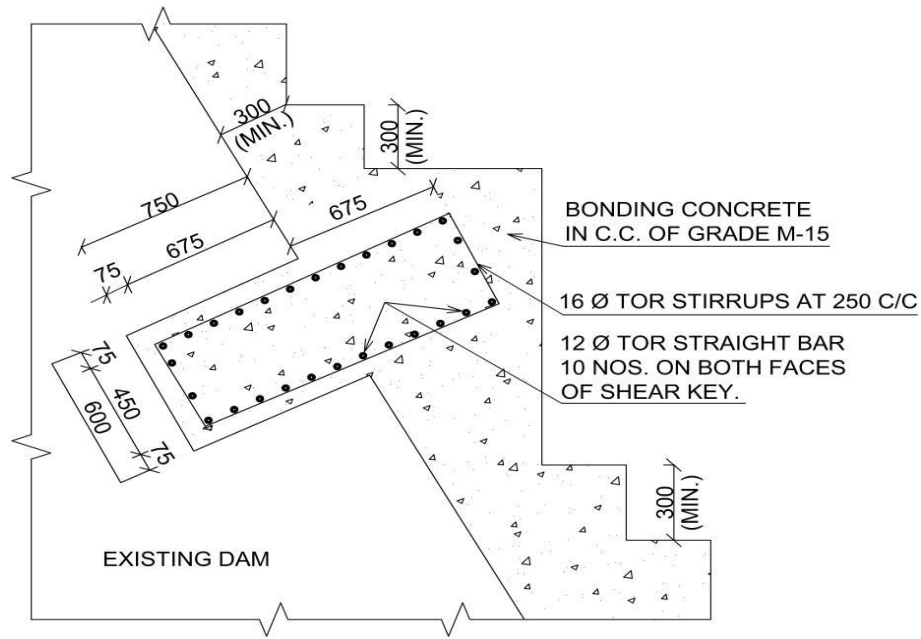

Figure 5-5: Typical details of Shear Key

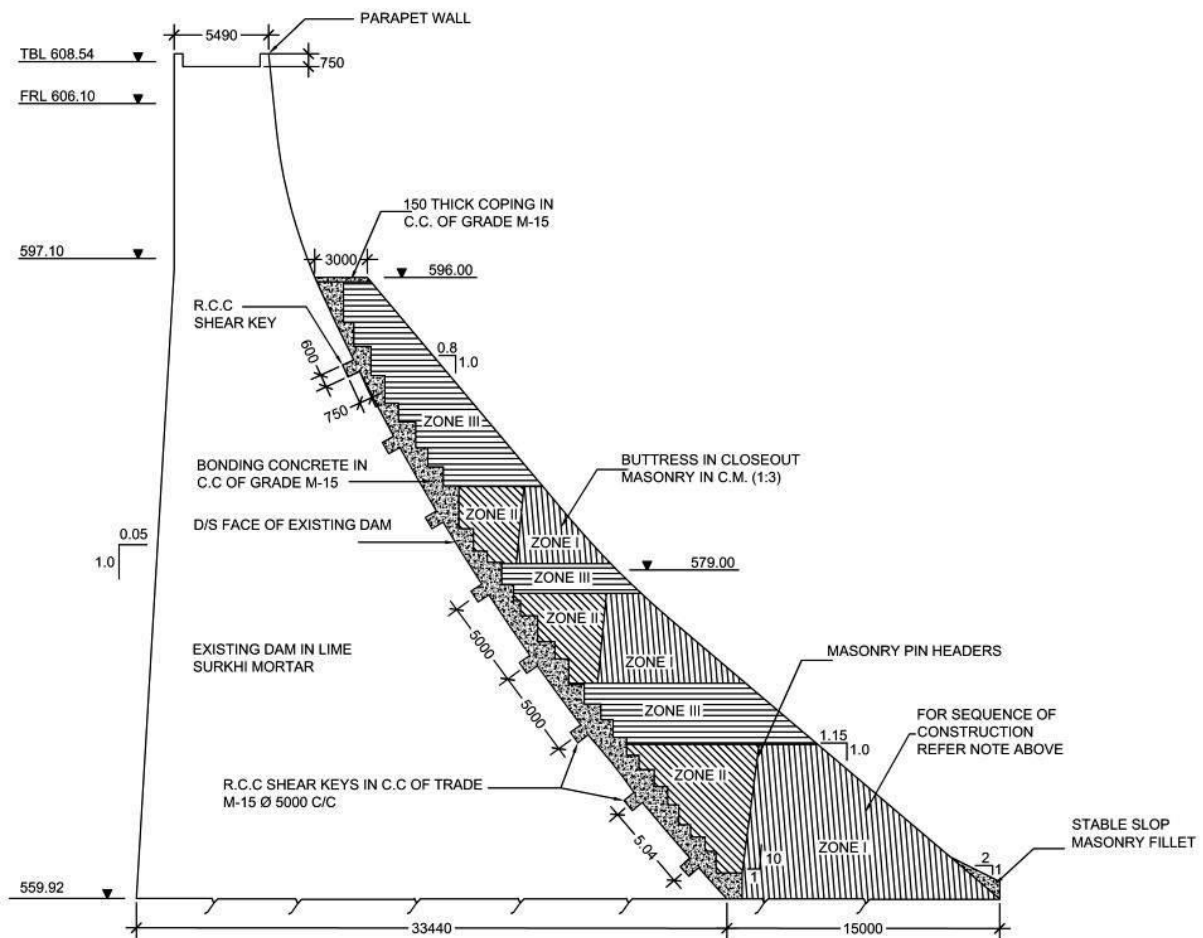

Figure 5-6: Sequence of Construction

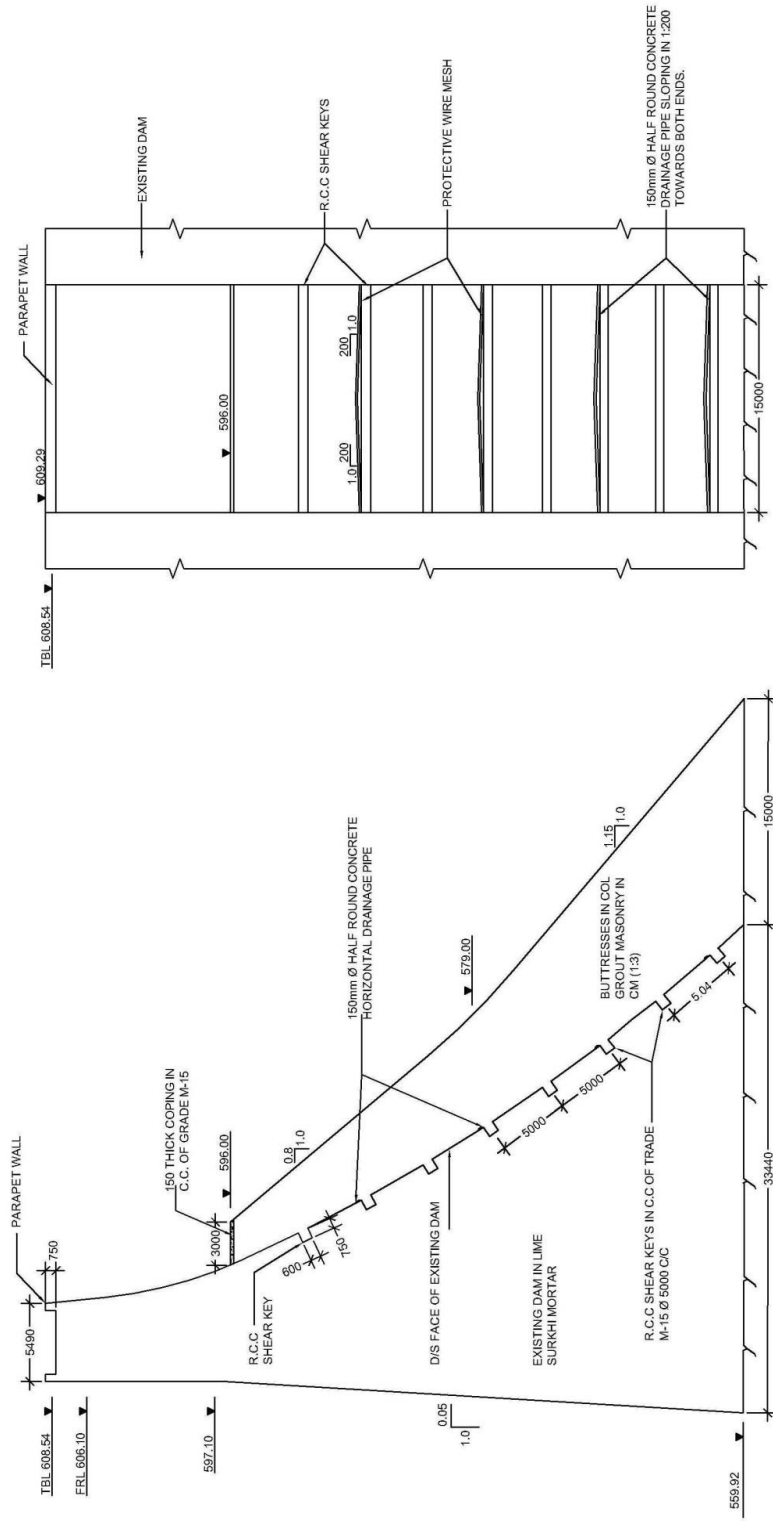

FIG:5.7 DRAINAGE ARRANGEMENT

Figure 5-7: Drainage Arrangement

**Annexure – I****RECOMMENDED GROUTING GUIDE/SPECIFICATION FOR REHABILITATION OF MASONRY/CONCRETE DAMS****1. Scope**

- (1) This specification covers the drilling and grouting work required to consolidate the masonry and the concrete within dam body and/or to form a grout curtain beneath the dam.
- (2) All work shall be carried out in accordance with this specification unless variation is discussed and approved by the contract Supervising Engineer. All points not covered by this specification shall be dealt with according to good practice or in case of doubt referred to the Supervising Engineer.

**2. Drawing**

Drawings detailing the work will be issued to the Contractor.

**3. Drilling equipment**

- (1) The drilling units employed shall be either percussive or rotary in type and shall be capable of drilling holes having a diameter of not less than 38 mm to full length of the holes shown on the drawings.
- (2) The drill shall be equipped to provide a continuous water flush of not less than 20 litres per minute issuing from the drill bit.

**4. Stages**

- (1) All holes shall be water tested and grouted in stages.
- (2) The stage length shall be between 4 to 6 m.

**5. Grout holes**

- (1) Details of layout and lengths of grout holes are to be shown on the drawings. The length of a hole shall be considered as the distance from the collar of the hole.
- (2) The diameter of the holes shall be not less than 38 mm.
- (3) Extra hole may be required by the Supervising Engineer after grouting records have been evaluated.
- (4) Prior to the final inspection of a section of the dam by the Supervising Engineer, the position of all holes shall be marked on the dam surface to be inspected. Upon the approval of the S.E. being given, the section of the dam surface shall be drilled and grouted in a sequence which is in accordance with the Section 6 below.

**6. Drilling and grouting**

- (1) Drilling and grouting is to be carried out either by Method A, described below, or one of the alternative Methods B and C. Annexure - A1 shows the alternative methods drilling and grouting.

**METHOD A: DOWNSTAGE WATER TESTING & DOWNSTAGE GROUTING**

Each stage is drilled, washed, water tested and grouted in succession down the hole. For both water testing and grouting, a packer is placed at the top of the stage.

If excessive water is lost during drilling, the procedure shall be as follows:

- a. The drilling shall cease and the hole shall be grouted in accordance with the Section 12. The contractor may choose the grout mix to be used.
  - b. Drilling may recommence 15 minutes after the completion of grouting.
  - c. In the subsequent grouting of the hole, the stage lengths and the grouting procedure shall be as if the preliminary grouting had not been carried out.
- (2) The grout holes shown on the drawing in an approved section of dam shall be treated as curtain holes and grouted in the following sequence:

(i)	Primary,	or 'P' holes
(ii)	Secondary,	or 'S' holes
(iii)	Tertiary,	or 'T' holes

Annexure -1B shows additional details on mixing grout and Annexure - 1C shows steps involved in drilling and grouting.

**7. Washing**

- (1) Washing of each stage of a hole shall be carried out at the times appropriate to the particular drilling and grouting method adopted.
- (2) The stage shall be washed by flushing with a flow of at least 20 litres per minute injected at the bottom of the stage until the return from the hole is clear or for a period of 10 minutes, whichever is the lesser.

**8. Water loss testing**

- (1) A water loss test shall be carried out on each stage of a hole at the times appropriate to the particular method adopted.
- (2) For each water test, water shall be injected under pressure into the hole for a period of not less the 10 minutes. The pressure to be applied for carrying out water loss tests shall depend upon the stresses at that point determined through stability analysis. However, as a thumb rule the pressure to be applied while carrying out water loss tests shall be 0.13 kg/cm<sup>2</sup> per metre depth of hole in masonry to be considered at the centre of the water loss test stage. Further, the applied pressure shall be such that it should not cause disturbance to the masonry / concrete.
- (3) For water loss testing procedures for masonry, IS: 11216- 1985 and IS: 5529 (Part 2) – 1973 are to be followed.

**9. Standard of Impermeability for masonry & mortar**

Masonry-

Standard of impermeability aimed at shall be a water loss of not more than 2.5 lugeon in the upstream and not more than 5.0 lugeon in the downstream portions of the masonry dam depending on the mortar mix used for masonry at that location (Rich or Lean mortar respectively).

Mortar –

Mortar as used on work shall not give a co-efficient of permeability greater than  $2.5 \times 10^{-8}$  mm/sec. for rich mortar and  $4.8 \times 10^{-8}$  mm/sec. for lean mortar.

#### 10. Remedial Measures

If the test results indicate water loss greater than specified values, grouting should be done as remedial measure.

#### 11. Grouting equipment

- (1) Grout shall be batched and mixed in a high speed mixer (“Colgrout” or other approved make) operating at 1500 to 2000 RPM.
- (2) Mixed grout shall be delivered to an agitator of the rotating paddle type.
- (3) Grout shall be passed through a 1200 micron sieve located between the agitator and the pump.
- (4) The pump shall be a screw-type pump (“Mono” or other approved make), capable of running at least 12 hours continuously under normal load.
- (5) Pressure gauges shall be reliable and regularly checked against a calibrated gauge.
- (6) Grout shall be pumped to the hole through hoses arranged
- (7) The volume of grout injected shall be obtained by measuring the change in level of the grout in the agitator tank or by the use of a grout flow measuring device approved by the Supervising Engineer.

Annexure - 1D shows arrangement of grouting process.

#### 12. Grout mixes

- (1) Grout shall consist only of a mixture of high-early strength cement and water, unless sand and bentonite are specified.
- (2) The cement used shall not have lumps.
- (3) Mixing time shall be sufficient for the grout to become uniform in colour and consistency but shall not exceed one minute.
- (4) The temperature of the grout shall not be greater than  $32^{\circ}\text{C}$  (when it is discharged from the mixer) and not to be lower than  $10^{\circ}\text{C}$
- (5) Grout kept in holding tanks shall be continuously agitated.
- (6) Grout mixes shall be designated by a number corresponding to the number of litres of water per 50 kg of cement, e.g. No 100 mix consists of 100 litres of water per 50 kg bag of cement.
- (7) Table 1 gives grout mixes which shall in general be used, and also the corresponding maximum number of bags of cement per stage to be injected if the stage takes grout freely.

#### 13. Grout injection

- (1) Grout pressure to be applied to each stage of a hole shall be the same as specified for water loss tests in the sections 8 (2) and 8 (3).

- (2) Grout injection shall normally commence with lean mix of 5.0:1 and in exceptional cases 10.0:1 may be adopted. However injection may start with a thicker mix if the water test result, or experience with previous holes, indicates that a thicker mix may be an advantage.

TABLE 1: GROUT MIXES

Mix No.	Litres of water per 50 kg of cement	Approximate Water: Cement (by weight)
500	500	10.0:1
400	400	8.0:1
250	250	5.0:1
200	200	4.0:1
150	150	3.0 : 1
125	125	2.5 : 1
100	100	2.0 : 1
75	75	1.5 : 1
50	50	1 : 1
25	25	0.5 : 1
20	20	0.4 : 1

- (3) In general a stage may be considered complete when the absorption of grout at the desired limiting pressure is less than 2 litre/min. averaged over a period of 10 minutes. When the intake of grout of one consistency has reached the above limit or when, in the judgment of the supervisor in-charge of the grouting, an earlier change to a thicker mix is warranted, the grout mix shall be thickened to one of the thicker mixes listed in Table 1. The injection process shall then be repeated for the grout of the new consistency.
- (4) The packer shall not be removed from the hole until at least 15 minutes after grouting has been completed. The packer shall remain in place until there is no back pressure.
- (5) Where grout emerges on the surface, every effort shall be made to plug the leak (using wedges, lead wool, quick setting mortar, plastic mastic or other material) before continuing with the injection.
- (6) If the stage has not been completed after 10 bags of No 20 mix have been injected, then injection using the No 20 mix shall continue intermittently by pumping for five minutes and stopping for 15 minutes. Annexure - 1E shows a format of grouting report.
- (7) When the intermittent grouting procedure has failed, a sand-cement-bentonite grout with the following proportions shall be used:

<i>Cement</i>	<i>1 part by weight</i>
<i>Sand</i>	<i>Not greater than 3 times the weight of cement</i>
<i>Bentonite</i>	<i>2% of the weight of the cement</i>
<i>Water</i>	<i>Proportioned to provide a readily pumpable grout</i>

The proportions may be varied in the light of previous or subsequent experience at each site. If the stage has not been completed after 40 bags of cement have been injected (in the form of the sand-cement-bentonite), the intermittent pumping and stopping procedure specified above shall be carried out until the stage is complete.

- (8) Drilled but un-grouted grout holes within 20 metres of a hole being grouted shall be flushed with water during grouting. When adjacent holes are being flushed during grouting, the colour of the water emerging from the adjacent holes shall be constantly observed to determine whether a grout connection has been made between the holes. If only faint dis-colouration of the water occurs, grouting of the original hole shall continue as if the connection had not occurred. However, if the original hole cannot be grouted successfully while there is a connection or if there is a strong flow of grout into the connected hole(s), flushing of the connected hole(s) shall cease and grout shall be allowed to emerge freely from the connected hole(s) until the consistency of the emerging grout reaches that of the grout being injected. Grout shall then be bled from the connected hole(s) intermittently until grouting of the original hole is complete. If a connected hole is “alive”, i.e. grout is still bleeding, it may be grouted immediately, starting with the grout mix which first emerged from the hole. Otherwise the connected hole shall be either washed out, or re-drilled, before grouting as if it were an unconnected hole.
- (9) Grout emerging from a hole shall be collected and discharged clear of the area where fouling or contamination of another grout hole could occur.
- (10) The grouting of a hole is complete when all stages have been grouted satisfactorily, and the hole is full of grout.

#### **14. Backfilling**

- (1) Backfill grouting of a hole shall be carried out with grout of No 15 mix or thicker
- (2) Backfilling of the entire length of the hole may be carried out in one operation.

#### **15. Records**

Progressively the grout hole numbers, locations, water testing results, grouting details and any other relevant information shall be recorded and forwarded to the Supervising Engineer who shall prepare drawings on which grouting results can be shown graphically.



**ANNEXURE - 1 A**

Alternative Methods of drilling and grouting:

Alternative methods for drilling, water testing and grouting shall be either downstage water testing and upstage grouting or upstage water testing and upstage grouting.

(1) **METHOD B DOWNSTAGE WATER TESTING & UPSTAGE GROUTING**

In this method each stage is drilled, washed and water tested in turn, using a packer at the top of the stage, before the next stage is drilled. After the last stage has been water tested, the hole stages are grouted progressively towards the collar of the hole using a packer at the top of each stage.

(2) **METHOD C UPSTAGE WATER TESTING & UPSTAGE GROUTING**

The hole is drilled to full length and washed. Commencing with the bottom stage, each stage is then water tested and grouted in succession towards the collar of the hole, using a packer at the top of each stage.

**ANNEXURE - 1B****MIXING GROUT****1. When Mixing Grout**

- a. Put the water in the mixer first
- b. Have the mixer running at full speed before adding the cement
- c. Mix the grout in batches (do not try to mix it in a continuous process)
- d. Measure the ingredients
  - (i) Preferably use a water meter to measure out the quantity of water required
  - (ii) Add the cement in whole bags. Do not try to use part of a bag
- e. Do not leave the mixer running for more than a few minutes between batches (it will get too hot)
- f. Have at least enough water in mixer to cover the rotor, whenever it is running
- g. Clean the mixer thoroughly after completion shift's work or if delays occur during grouting ensure that all grout is removed from inside and outside of mixer, and from rotor and hoses

**2. Efficiency Check on Grout Mixers**

To carry out an efficiency check

- a. Check the R.P.M. of mixing rotor
- b. Make a sample of grout about one inch deep. When set, break it apart and examine the grain structure of a vertical face.

The mixing is efficient when vertical face is uniform in colour and has no banding.

The mixing is inefficient when vertical face has horizontal bands of different colours (indicating segregation of various particles sizes of the cement)

ANNEXURE – 1 C

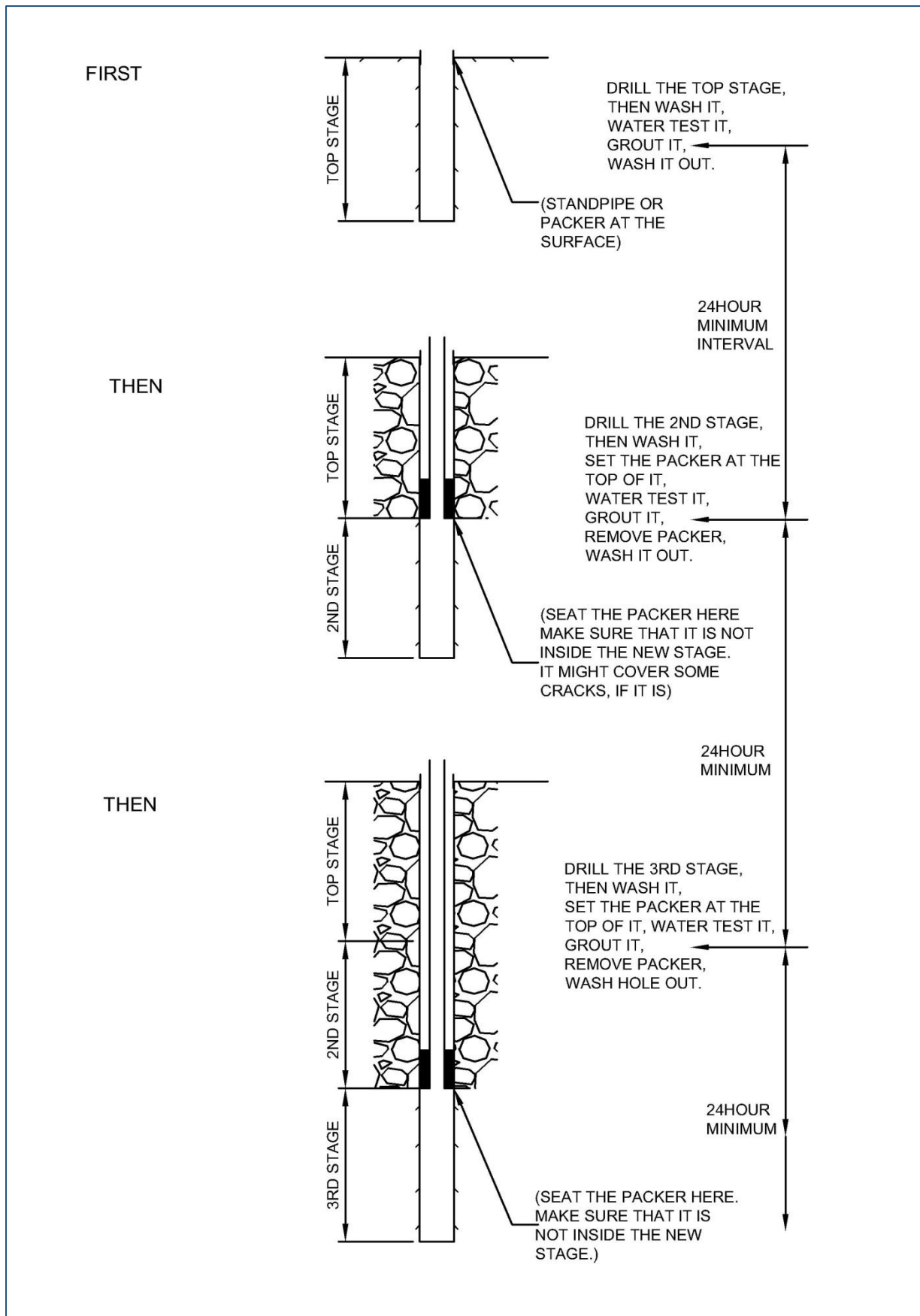

ANNEXURE – 1 D

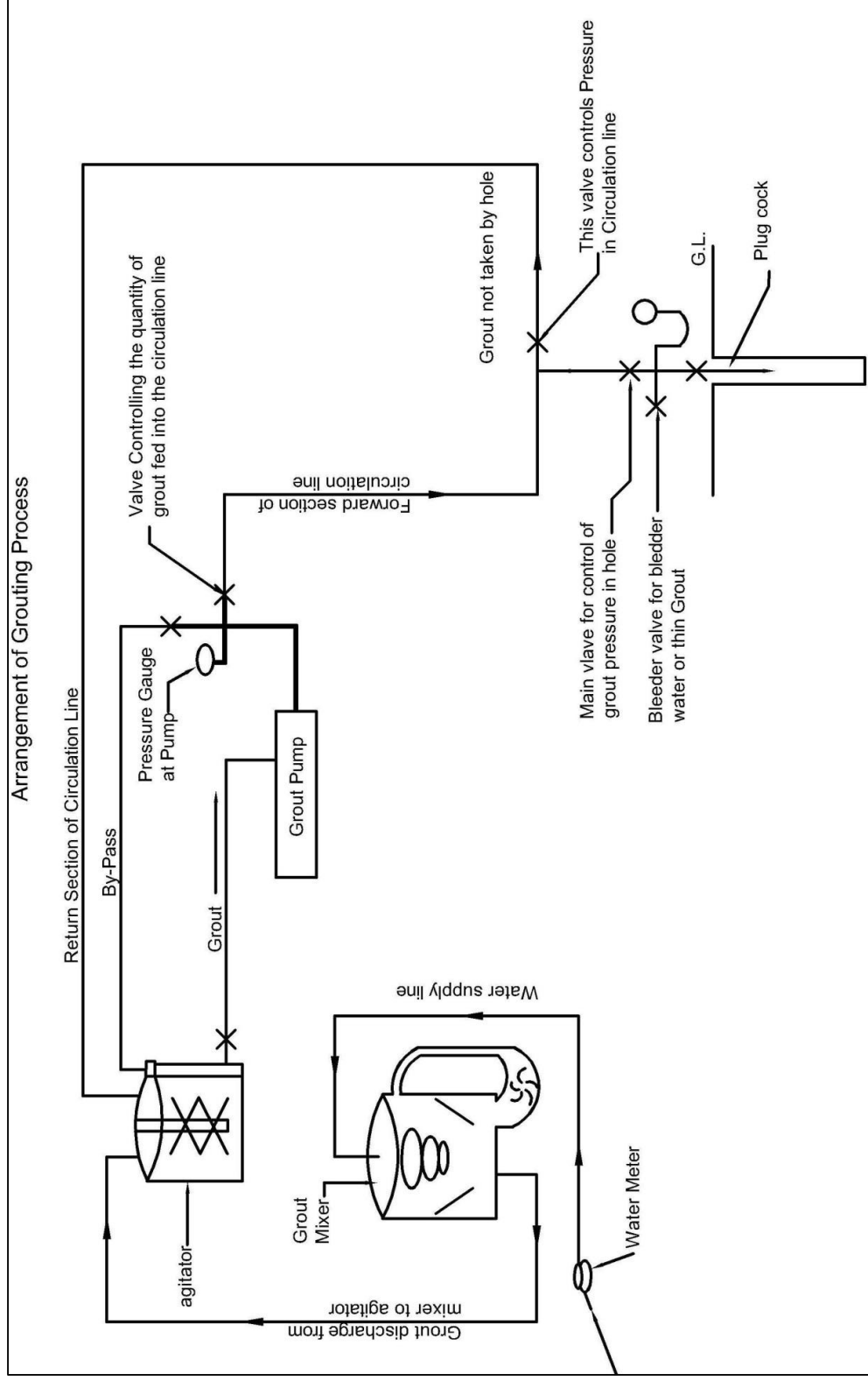

**ANNEXURE - 1 E**

<b>GROUTING REPORT</b>											
Project Name - Contract - 1											
Client:											
Engineer:											
Contractor:											
TYPE OF GROUTING.....											
HOLE No. ....											
CONTRACTORS FORMAN.....											
CONTRACT NO.....											
INSPECTOR.....											
LOCATION.....											
STAGE DEPTH..... M TO.....M											
APPLICATION ..... OF .....											
INCLINATION TO .....											
STAGE LENGTH.....M*100 =.....CM											
VERTICAL.....											
REMARKS											
Connections - uplift - waste details - plant difficulties, etc.											
PRESSURE AT STAND PIPE (BARS)											
TOTAL IN PERIOD (BAGS)											
NETTING: PAY WASTE (BAGS)											
CEMENT TAKE											
GROUT (LITRES)											
WASTE PAID UNPAID											
IN TANK INJECTED											
START FINISH											
BAGS CEMENT ADDED TO MIXER											
W/C BY Weight											
PERIOD in Min											
TIME FROM TO											
DATE											
TOTALS .....											
SHEET ..... OF .....											
TYPE OF DRILLING.....											
CEMENT TAKE = .....											

## Chapter 6. REHABILITATION OF EMBANKMENT DAMS

Embankment dams are particularly sensitive to failure caused by overtopping, both during construction and while in service. Overtopping of a dam often causes dam failures. Worldwide statistics show that overtopping because of inadequate spillway capacity, inoperative spillway gates, debris blockage of a spillway or settlement of the dam embankment crest accounts for about 34% of all embankment dam failures.

Also sometimes the embankment dams which are not compacted as per specifications which can result in various deficiencies.

Rehabilitation of an embankment dam is intended to overcome one or more of the problems listed below:

- Instability associated with internal erosion (piping) of the embankment, its abutments or its foundation by seepage of water from the reservoir.
- Slope instability caused by a shear failure in the embankment or foundation. High pore-water pressure within the fill can be one of the primary reasons for the loss of shear strength. A secondary cause of loss of shear strength is material degradation. It is generally observed that failure because of slope instability has rarely led to an uncontrolled release of water.
- Instability due to external erosion of the embankment on account of overtopping due to insufficient spillway capacity. The rehabilitation usually aims to increase the spillway capacity or raise the dam height. Reinforcing the dam crest and paving the downstream slope have also been attempted in some dams.
- Instability caused by the external erosion of the upstream protection works viz. rip rap as a result of wave action.

This can lead to rapid erosion of the upstream slope.

- The loss of bond between a concrete structure and the earth or rockfill embankment.
- Insufficient seismic stability. This may result from liquefaction of the material in the foundation or in the embankment. Hydraulic fills dams and foundations consisting of saturated fine sand or silty sand are prone to loss of shear strength under seismic shaking.

The two key indicators of deterioration in an embankment dam are deformation and seepage flow. These can be detected by visual surveillance supplemented by instrumentation. Each of these key indicators are discussed below.

### 6.1 Deformation

Various movements and deformations happen in all dams. Horizontal movement occurs in an upstream-downstream direction, but may also occur along the dam axis (usually toward the valley). It can involve the movement of an entire dam in relation to its abutments or foundation, or one part of a dam in relation to another. The downward vertical movement caused by the consolidation of the dam or of the foundation is called *settlement*.

Reservoir levels can have a major influence on movements.

Indicators of deformation in embankment dams include the following:

- an excessive rate of general settlement,
- a differential settlement,
- an increased rate of settlement,

- a localized settlement or sinkhole in the crest or dam slopes, and
- slumping of the upstream or downstream slope associated with shallow- or deep-seated slope failure.

## 6.2 Seepage flows

Because the purpose of a dam is to store water efficiently and safely, its water-retention ability is of prime importance. *Seepage* from a reservoir is the interstitial movement of water through a dam, the foundation, or the abutments. It is different from *leakage*, which is the flow of water through holes or cracks. Seepage through an embankment dam should not be significant enough to erode material from inside the dam body. Such internal erosion can cause undermining or piping.

Indicators of seepage in embankment dams include the following:

- the sudden emergence of seepage or leakage on the downstream slope, valley sides or valley bottom;
- an increase in flow rate or turbidity of existing seepage flows;
- a marked change in piezometric level within the dam or its foundations;
- a high pore pressure downstream of the watertight element; and
- leakage into an outlet conduit/tunnel.

## 6.3 Internal Erosion

Internal Erosion or piping can occur through the foundations, abutments or the core of an embankment dam. The first signs could be increased/concentrated seepage observed at certain locations/spots.

Seepage through the dam/foundations can increase due to a number of reasons. In rock foundations it may be due to deterioration of the grout curtain, solution of minerals in the foundation like gypsum or limestones,

erosion of the infillings in the joints/faults/shear zones etc. In soil foundations & dam cores the nature & type of the material used, quality of construction, filters etc. will influence the seepage. The suitability of soils for use in an earth dam is discussed in IS: 1498 Classification and Identification of Soils for General Engineering Purposes & IS: 12169 Criteria for Design of Small Embankment Dams.

Internal erosion or piping is mostly associated with increase in quantity of the seepage flow and its turbidity. Formation of sink holes has also been observed in many embankment dams with piping issues. Chemical and isotope analysis of the seepage water or traces such as dyes or chemicals can help detect dissolved minerals and to reveal their source. Rehabilitation measures to deal with excessive leakage and internal erosion through the abutments, foundation and impervious core include:

- Provision of filters designed to prevent the migration of soil particles where feasible.
- Drains, galleries or relief wells to adjust to a safe level the hydraulic gradient in the foundation, particularly at the location where the flow emerges.
- Grouting of the foundation/impervious core.
- Installing a continuous diaphragm wall cut-off. This can be formed by excavating a trench or by drilling overlapping holes, or by the technique known as *jet grouting*.
- Increasing the length of the seepage path by the use of an impervious clay blanket upstream.
- In some circumstances, the problems may be so severe that the optimum economic solution may be to dismantle the dam in the affected reach and then reconstruct it as per a fresh design.



### 6.3.1 Filters and Drains

Langbjorn Dam, in Sweden (Nilsson & Mikaelsson, 1996) is an example of successful rehabilitation by drainage of the abutment together with a stabilizing berm. It reveals the difficulty sometimes experienced with cores of glacial moraine material because of its poor resistance to internal erosion (see Figure 6-1).

The dam is a 32 m high earth fill dam in Sweden. It founded on both soil & rock. The left abutment is an extension of the dam. It contained sandy soil.

During the first filling of the reservoir in 1958 excessive seepage and erosion was observed near the left abutment. Also a slide occurred in the downstream side of the abutment. Provision of blankets of filter material & shallow drainage holes from 1958 to 1986 did not help. In 1990 sink holes were observed on the surface of the abutment. A slide took place in the area in 1994.

The rehabilitation works carried out there after included provision of 25 m long, 100 mm diameter horizontal drainage holes & a stabilizing berm of permeable material at the

toe. Stand pipe readings after rehabilitation indicate a considerable lowering of the ground water levels in the area. Some of the pipes have also become dry. Monitoring & evaluation of measurements through stand pipes was recommended.

### 6.3.2 Grouting

Pressure grouting was invented and first applied in 1802 by Charles Berigny in France. The first use for dam rehabilitation in the United Kingdom was at the Walshaw Dean Reservoir in 1911. Grouting in the United States dates back at least to 1893 when cement grout was injected into the limestone foundation of a dam in the New Croton Project in New York State (Weaver and Bruce 2007).

The following is in brief the summary of the grouting techniques in use. Suspension grouts of ordinary Portland cement can penetrate gravel and coarse sand while fine cement can be used to grout fine-grained materials. Chemical grouts have also been found effective in grouting fine-grained material. However, concerns over environmental and groundwater pollution have limited the use of chemical grouts, and fine-grained cement is often selected as a safer alternative

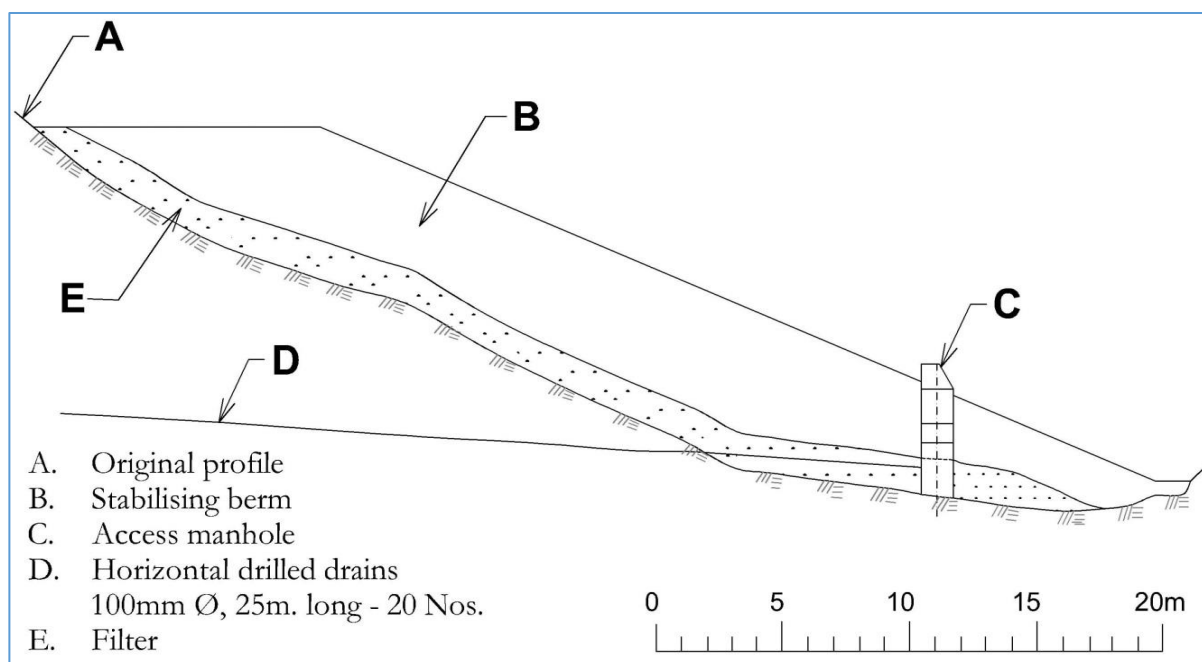

Figure 6-1: Longbjorn Dam, Sweden - Cross section of abutment (Horizontal drains and stabilizing berm)

to chemical grout. Ideally, grout should be designed to match the parent material in density and shear strength while being satisfactorily penetrative. This has proved to be a challenging task. A bentonite content of 2% to 5% of the cement weight is often needed to achieve a stable suspension.

Super-plasticizers have been used to reduce the viscosity of the grout and improve its ability to penetrate. It has sometimes been used instead of bentonite for grouting.

Sleeved pipes (known as *tubes-à-manchette* in France, where they were first introduced in the 1930s) can be used in applications where the material to be grouted is so weak or loose that grout holes cannot be kept open (Weaver and Bruce 2007, pages 290-292).

In its simplest form, the sleeved pipe is a plastic pipe with perforations at uniformly spaced intervals. These perforations are covered with short rubber sleeves that can be forced aside by the pressures of grout injected through a dual packer that is used to isolate a group of perforations. Before being used, the sleeve tube is installed in a cased hole that is backfilled with sleeve grout (typically consisting of 10% bentonite with water and cement in proportions of 3:1 by volume) before the casing is withdrawn. The annulus-sealing sleeve grout is fractured when pressure is applied via the packer placed in the tube, allowing fluid grout to be injected by permeation. Multiple applications can be made where desired. Although best known for its application in alluvial grouting, the sleeved pipe method has also been widely used to treat mechanically poor rock conditions.

Repairs to Greenbooth Dam (Flemming and Rosington, 1985) illustrates the difficulty of designing one grout to do all the functions in that dam like reducing the permeability, filling the cavities in the core, and being suitable for use with sleeved-pipes.

Grouting can be carried out from the crest of the dam, from specially constructed galleries within the embankment close to the contact with the foundation, or from adits driven into the abutments. Care must be taken to prevent damage to the embankment–foundation contact zone. Although well-designed grouting can reduce seepage and arrest the erosion process, it can rarely be considered as a final measure. Repeated treatments are often needed, either because of continuing deterioration or because the grout may not have succeeded in filling all the gaps.

Some of the Indian dams in which alluvial grouting has been done in original designs (not for rehabilitation works) are:

1. Girna Dam in Maharashtra, India – It is a 33 m high zoned earth dam. Overburden in the river bed was about 12 m deep clear sand with  $d_{15}$  more than 1 mm and permeability of about 0.1 cms/sec. Due to problem of de-watering, a partial cut-off trench of about half the depth was provided, and it was decided to treat the rest by grouting. Bentonite cement grouts used initially reduced the permeability to about  $1/10^{\text{th}}$  only. Silicate-Aluminate grouts were used later under pressure upto 6-7 kg/cm<sup>2</sup> and succeeded in reducing the permeability to below  $5 \times 10^{-4}$  cms/sec. The basic mix used was as below-

Sodium Silicate	3 Litres
Sodium Aluminate	110 gms.
Water	5 Litres

Piezometer indicated a head drop of over 94 % across the curtain

2. Obra Dam, Uttar Pradesh, India-

At Obra Dam alluvial grouting was used for 3 m wide sand between two concrete diaphragms cut offs.

Two rows of holes were made, 1 m clear of the inner face of the dia-

phragm. The holes were 3 m apart and staggered for the two rows, alternate holes 6 m apart, were first grouted by cement-bentonite grout of the following mix per cubic meter of the grout-

Water	862 liters,
Cement	300 kg.
Bentonite	100 kg.

The pressure in no case was allowed to exceed 15 kg/cm<sup>2</sup> and was generally at 10 kg/cm<sup>2</sup> or less.

Intermediate holes were then grouted with a grout of the following mix for a cubic meter of the grout-

Water	910 litres,
Bentonite	105 kg
Sodium monophosphate	40kg
Sodium Silicate	35 litres.

Besides diaphragms and grouting the dam is also provided with 45 cm dia. relief wells 30 m apart having full penetration.

Examples of some of the Earth dams under the DRIP project in which grouting is being/has been carried out are:

1. Sarathi Dam, Madhya Pradesh: This is a 1995m long and 17.68 m high homogeneous earth dam. Piping in the dam body and heavy seepage was observed at certain locations. The pipe formations were treated/filled earlier.

Further two options were suggested. The first option consisted of provision of a soil-cement-bentonite diaphragm wall whereas the second option consisted of provision of three rows of grouting with chemical and cement or cement mixed with bentonite.

The second option was adopted and the seepage has been controlled.

The dam has also been raised by 2 m from hydrological considerations (increase in design flood). The dam extension is on the downstream side with both inclined and horizontal filters.

2. Malankara dam, Kerala: This is a composite dam 460 m long consisting of a masonry dam and spillway in the right bank and river bed and a earth dam 206 m long in the left bank. The maximum height of the earth dam was 12 m.

The core of the earth dam was grouted with soil-bentonite slurry containing 2% bentonite in 5 rows under low pressures (max. 2.5 kg/cm<sup>2</sup>).

### 6.3.3 Diaphragm Walls and Cutoffs

Cut-offs have been chosen for rehabilitation where degradation in the foundations is too large for grouting to be carried out economically. For example, the diaphragm installed at Balderhead Dam (Vaughn et al. 1970) was necessary because of the large scale internal erosion experienced there following hydraulic fracture of the core.

Detailed case history of Balderhead dam, UK is given below:

*Balderhead Dam, UK, is a 48 m high embankment dam. It is 925 m long. It has a rolled boulder clay core, relatively stiff shale fill shoulders and a concrete cutoff. The top 10.8 m of the clay core has vertical sides. Immediately downstream of the core is a crushed limestone filter which connects with the ground drainage blanket. The filter and the drainage blanket were designed according to standard filter rules.*

*On first impounding in 1966, just before the reservoir was full, the seepage flow increased. Subsequently, localised settlements occurred along the crest and in 1967 two sinkholes formed in the crest. The reservoir was immediately drawn down by 9.2 m*

*and the seepage flow brought to its previous level. It was established that the seepage flow had turned cloudy about a month before the first sinkhole appeared. After drawdown the water became clear.*

*Exploratory boreholes revealed erosion within the core at several locations; the boulder clay material had become segregated and the finer particles lost by water erosion. The damage was associated with cracking which had been initiated by hydraulic fracture of the core under almost full reservoir pressure (Vaughan et al, 1970). Low stresses in the core were perhaps caused by arching across the clay core between the relatively stiff shoulders and possibly by longitudinal strain due to differential settlement across foundation discontinuities. It was also concluded that once the cracks had formed they were kept open by the water pressure and under the low flow conditions the coarser eroded material had segregated in the cracks. On drawdown the seepage paths closed up due to the decrease in water pressure.*

*In the central 200 m length of the dam, covering the zones of worst damage, the core was repaired by constructing a 600 mm wide diaphragm wall down to the concrete cut-off. The depth of the trench varied from 31 m to 46 m and the panels were 6 m long. The work was carried out with the reservoir level lowered by 10 m. The plastic concrete mix was designed to have a strength and stiffness (viz. density & shear strength) similar to that of the rolled boulder clay core and be resistant to erosion. The mix proportions adopted are given below.*

	<i>Proportion as % of weight</i>
<i>Ordinary Portland Cement (OPC)</i>	<i>9.7</i>
<i>Bentonite</i>	<i>2.0</i>
<i>Aggregate</i>	<i>69.0</i>
<i>Water</i>	<i>19.3</i>

Diaphragms are reliable, though expensive forms of construction for improving the strength and impermeability of foundation or embankment.

Where required a diaphragm wall can be constructed through the embankment up to

about 1 m below the foundation rock to reduce seepage to the desired level. Several methods are commercially available for forming the trench. Bentonite slurry is used to stabilize the trench excavation. The trench can be excavated with a rock mill through the embankment and into the foundation. As soon as the trench is fully excavated, each diaphragm panel is backfilled with concrete which displaces bentonite slurry to form the wall. The wall, often 600mm wide, is usually constructed in panels up to about 4m long. It is normally keyed into bedrock. Care must be taken to ensure that adjacent panels fit tightly together and that they are accurately vertical. *ICOLD Bulletin 51* (ICOLD 1985) gives useful information on the construction techniques and materials used for slurry stabilizations of the excavation. The diaphragm wall may be of either rigid concrete or plastic concrete, depending on the stiffness and long-term behavior of the foundation materials. Normally plastic concrete is used in a diaphragm wall when it is to be used as a seepage barrier only & ordinary concrete with reinforcements wherever there is also a structural requirement.

An alternative approach to forming a diaphragm cut-off is to auger through the embankment or to excavate it with a clamshell. Uljua Dam in Finland (Kuusiniemi 1991) is an example of this technique. The holes are later filled with concrete. Secondary elements are installed by excavating the space between the primary elements with a clamshell and rock chisel under a head of the bentonite slurry. A third method is to install overlapping concrete piles, known as secant piles.

In India though diaphragm walls have been provided in the original designs of some dams they are yet to be used for rehabilitation purposes.

Jet grouting is a more recently introduced technique that can improve poor foundations in a soft material at a lower cost than a diaphragm wall. In this technique, a hole is

drilled with a tricone bit with bentonite. The cement-based grout is then injected under high pressure (about 45 MPa) as the drill string is rotated and slowly withdrawn from the hole. The spacing depends on the equipment available and the nature of soil and is usually between 500 mm and 800 mm. Specialist literature needs to be consulted for details. Schneeberger et al. (1991) give convincing evidence that adjacent holes can overlap satisfactorily.

### 6.3.4 Sheet Piling

Sheet piling has been used in the rehabilitation of embankment dams to control leakage in the core. Although the method is cheap and simple, using well established techniques, it has limited applicability. Generally sheet piling has been used to solve leakage problems near the top of embankment with a maximum depth of 5 m. Lemelin and Jobin (1996) describe the installation of sheet piles and jet grouting to rehabilitate a decomposing embankment. Dyke No. 3 at Lake Manouane was originally constructed as a rock-filled timber crib dike about 10m high. In 1961, the dike was raised 3 m and converted into a zoned rock-fill embankment featuring an upstream impervious layer, a 1.2-meter-thick vertical sand filter placed between the impervious earthfill and the original plank facing of the cribs, and a downstream shell consisting of the original timber cribs with more rock fill.

Design studies focused on the use of sheet piles to replace the decomposing timber facing. Among the advantages were the structural flexibility of sheet piles and their relative insensitivity to possible long-term deformation of the timber cribs and the brief period needed for installation. Stiff piles were selected to reduce damage during installation and to give an acceptable service life. A 315-meter-long section was constructed using 250 pairs of piles. Care was taken to ensure that the piles were vertical and the entire 3100 m<sup>2</sup> of sheet piling was installed in 20 working days. The triangular windows between the base of each pile and

the granitic bedrock were sealed using jet grouting at a pressure of about 35 MPa.

### 6.3.5 Clay Blanket

The installation of a clay blanket upstream of the dam is a traditional technique. Its purpose is to lengthen the seepage path through the foundation and to reduce the hydraulic gradients that ultimately drive the processes of deterioration.

### 6.3.6 Reconstruction and Replacement of the Core Section

Reconstruction/Replacement of the core section of a dam may sometimes be the most economical and reliable option after consideration of all the alternatives. The damaged section could be dismantled/removed & in its place a new section could be considered for construction.

This opportunity can be utilised to change the design, for example by widening the core and using more conservatively designed filters to achieve higher safety against internal erosion in the reconstructed length. Modifications in the core section by filling an open trench with a cement-bentonite mix is another technique that has been used, notably in the United Kingdom (Charles et al. 1996).

A relevant case history is that of Grundsjon Dam, which has three earthfill embankments, of which the tallest is 44 meters high (Eurenius and Sjödin 1991). The dam was completed in 1972 and is built on the Ljusnan River in Sweden. The central moraine core is surrounded by filters and is founded on rock and the shoulders are on moraine. In 1990, a sinkhole, 400 by 500 mm and 1.6 m deep, was formed in the upstream part of the crest above the zone of the upstream filter (Rönqvist et al. 2015). Exploratory drilling through the dam and measurements showed that the core was damaged. Economics favored reconstruc-

tion over grouting. A 5-meter-long section of the core was excavated and replaced on either side of the sinkhole. During the reconstruction, an erosion path having a flow area of  $0.5 \text{ m}^2$  through the core was discovered. No fines were found in the erosion path, suggesting that the sinkhole was a consequence of internal erosion. The erosion started from the downstream face of the core and progressed upstream towards the upstream filter and finally reached the crest of the dam. A drainage system has now been installed downstream of the dam. The instrumentation and monitoring programs have been extended (Figure 6-2).

### 6.3.7 New filters and Drain Provisions

It may not be practical to repair the filter downstream of the core, which is normally inaccessible. Filter and toe drain can however be incorporated in a new berm provided on the downstream which has been designed to improve the stability of the embankment. The stability of the d/s slope of the dam & the d/s berm will need to be ensured.

## 6.4 External Erosion

### 6.4.1 Upstream Protection

Damage to the upstream slope protection may be caused by the action of waves, fracturing of the stones of the rip rap, or freeze-thaw phenomena.

The last of these is reported for Sveg Dam in Sweden (Cederwall and Nilsson 1991). The damage can occur abruptly, leading to a loss of functions of the protection and a resulting loss of freeboard (Carlyle 1988).

Alternatively, the damage can be progressive, allowing time for repairs without loss of function.

Erosion of riprap on the upstream face is a potentially serious condition and if left untreated can lead to the destruction of the dam under the effect of wave action. Surface erosion can be seen visually during routine surveillance. Photogrammetry has been found to be useful for watching localized movements on embankments (Hopkins et al. 1990). The options generally considered

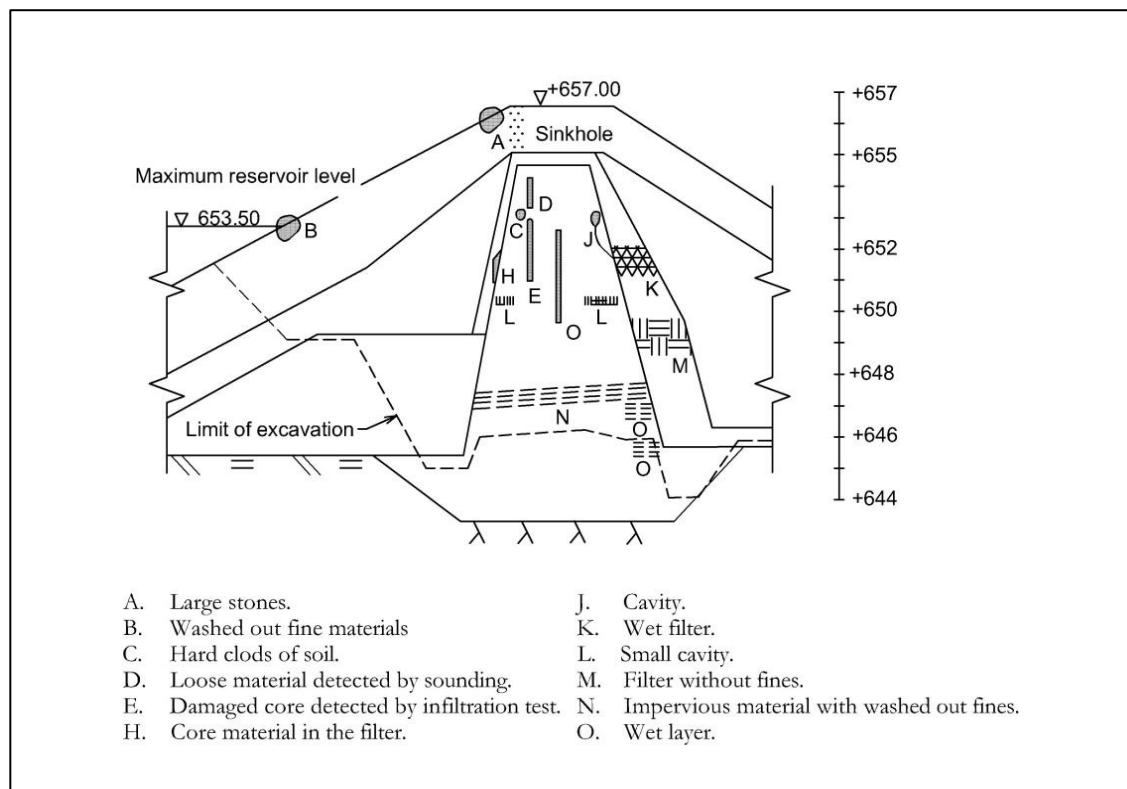

Figure 6-2: Grundsjon Dam, Sweden - Cross section of damaged core

for the repair of u/s riprap include:

- Strengthening the existing protection works by constructing larger size panels by concreting, made using existing stones in rip-rap.
- Increasing the size and thickness of the riprap.
- Grouting of the u/s rip rap in vertical & horizontal strips with asphalt/concrete.
- Restoration of the disturbed rip rap as per original design.

The longevity of these methods is still to be assessed.

The rehabilitation of Megget Dam in the United Kingdom (Gallacher et al. 1998) was carried out by pattern grouting of the existing rip rap in a 2.5 m grid of grouted strips. Bituminous grout was used for the purpose.

The stone pitching on the upstream face of Carron Dam, also in the United Kingdom, had repeatedly been damaged and maintenance was becoming necessary almost on an annual basis. Following major damage in the winter of 1996/97, a permanent solution was sought. The existing pitching, laid on a 1(V) :3(H) slope, was 300 mm thick, over a 150 mm filter layer.

It was seen that existing thinness of rip-rap was not adequate.

The design minimum effective size of stone required was 0.49 m<sup>2</sup> and preferably greater than 0.79 m<sup>2</sup>. As the existing pitching protection was inadequate to withstand extreme events, the effective size of the stones was improved by making concrete panels using existing stones of rip rap. The panels were 450 mm deep, over a 100 mm thick broken stone drainage layer and a layer of geotextile filter fabric. The panels were finished by grouting the stones using a sand/cement high strength grout. Gaps between the panels were maintained to allow drainage.

Under the DRIP the disturbed/settled rip rap on the upstream face of embankment dam has been re-laid along with filters in a number of dams.

#### **6.4.2 Crest of the dam, Parapet walls & downstream slope of the Embankment Dam**

Normal repair works carried out include:

- Reconstruction of road on dam top if damaged or in poor condition,
- Repair of damaged parapet walls,
- Improvement in drainage arrangements,
- Provision of turfing on downstream face,
- Improvement to steps on downstream slope
- Repairs to toe drains
- Re-sectioning of the dam section as per design section including taking sections at every 50-100 m intervals.
- Construction/repairs to d/s loading berm, relief walls etc

In the rarest possibility of some overtopping during high floods, it may be necessary to improve the resistance of the downstream surface for the water flows. Options that can be considered for strengthening the surfaces include:-

- cast-in-place reinforced concrete,
- roller-compacted concrete,
- soil cement, and
- articulated concrete block revetment systems.
- Wire crates

However, a detailed study will be necessary including literature survey, model tests etc.



## 6.5 Loss of Bond between Concrete Structure and Embankment

Deterioration of embankments adjacent to concrete/masonry dam structures or dam abutments may be associated with differential movements in the contact zone. A consequence of this is increased seepage at the interface and possibility of internal erosion. Displacements in the transition zone between the embankment and the concrete/masonry structure may be due to the settlement of the embankment material caused by poor compaction at the contact area or settlement of the foundation resulting from inadequate treatment. Such settlements often result in arching in the fill material causing a reduction of the effective stress, and hydraulic fracture. This may lead to the development of seepage paths in the form of cracks, more porous layers in the embankment, or along the face of the concrete structure, promoting internal erosion. Nilsson and Mikaelsson (1996) describe the Swedish experience of internal erosion in embankment dams close to the contact with structures composed of concrete.

The deterioration can usually be detected by visual observation, geotechnical investigations, settlement readings and measurement of increasing seepage rates. Increased monitoring is recommended once the deterioration process has been noticed and assessed, to decide when rehabilitation measures should be undertaken.

Reduction of seepage by grouting could be an option. Roxo Dam (ICOLD 1983) is an example where grouting was carried out in the contact zone. This was done from a drainage gallery/tunnel constructed below the embankment dam in rock. Drainage holes were also provided.

However reconstruction of the embankment is perhaps the best remedial measure subject to techno-economics.

While doing so the following provisions need to be considered :- (a) wider excavation in foundation (b) wider impervious core in combination with adequate compaction and moisture control, (c) slightly sloping concrete /masonry structure at the transition surface to the fill to improve contact as a result of compaction of consecutive layers, (d) wide filters, (e) conservative drainage provisions.

## 6.6 Slope Stability Improvement

The stability of embankment slopes can be improved either by adding weight berms, by flattening the slope, by adding weight at the toe of the embankment, or by improving the drainage to reduce the pore pressure in the downstream fill. Giffaumont Dam, France (Bister et al. 1994) is an example of the benefit derived by a simple addition of a free draining layer/stabilizing fill on the downstream slope at a slope of 3 (H) : 1 (V) (see Figure 6-3).

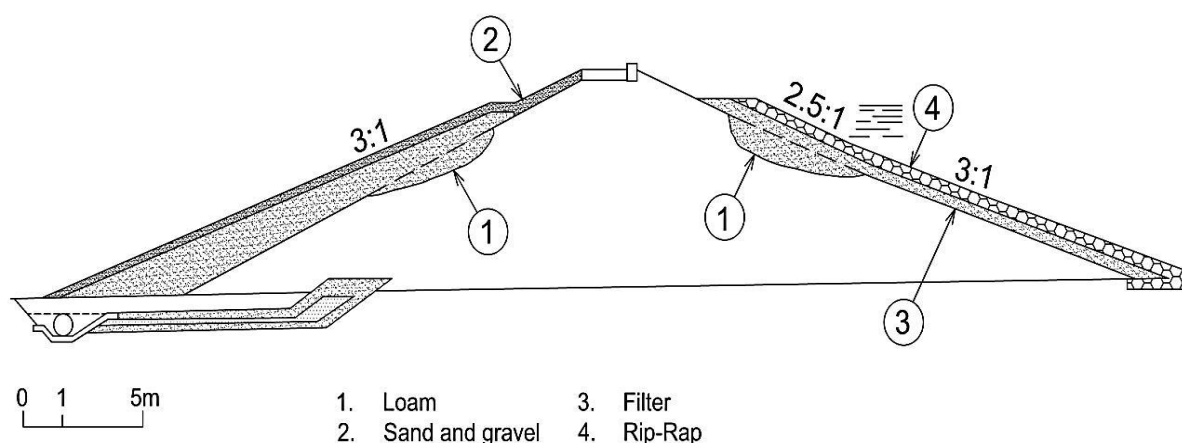

Figure 6-3: Giffaumont Dam, France - Cross section of rehabilitated embankment

Ajaure Dam in Sweden is a 46 m high rock-fill dam with a central impervious core of glacial till supported by filter zones on the upstream and downstream side. The shells are made of rockfill from the excavation of appurtenant structures and the powerhouse. The central high part of the dam is founded on rock, while the abutments are founded on glacial till. The crest has been subsequently raised by 1 m leading to slopes of 1 (V) :1.35(H) to 1.40(H) in the upper 12 m of the dam. Below this level the downstream slope is inclined at 1(V):1.8(H). The dam, was completed in 1966 (Nilsson et al, 1991) (see Figure 6-4)

About 20 years after construction it was noted during an engineering inspection that the records from an observation point along the crest of the dam showed continuing horizontal movements with no decreasing trend. Observations were intensified. An analysis of the readings indicated that while the rate of vertical settlement of the crest had decreased to about 1 mm to 2 mm per year, (10 years after impounding) the horizontal displacements were continuing at a rate of 7 mm/year downstream. The readings revealed that the reservoir level significantly influenced the horizontal deformations.

Field investigations were initiated at this stage to provide basic data to analyse the

reasons for deformations, and for the design of possible rehabilitation measures. Test pits were excavated at the downstream toe of the dam and along the crest. The rockfill comprised schists and gneiss with a high content of mica. The shear strength of the minus 60 mm material was determined in a large shear apparatus. Crushing occurred to a large extent during testing. The results of these tests established the weakness of the material at high shear stress, as well as the exceptionally low shear strength of the material compared with other published data.

Stability analyses performed with the results of the shear strength tests indicated a factor of safety of 1.17 for the most critical surface. This compares with 1.27 assumed during the design. The shear stresses in situ were therefore close to the shear strength. It was concluded that this situation, combined with the cyclic loading from the reservoir, resulted in the progressive crushing of the rockfill and that crushing was causing the horizontal deformations.

Remedial measures comprised incorporating a 13 m wide berm at about dam mid-height on the downstream side. The slope of the berm has an inclination of 1(V): 2(H).

The minimum factor of safety was increased by about 10 percent by using a stabilizing berm. (see Figure-6-5).

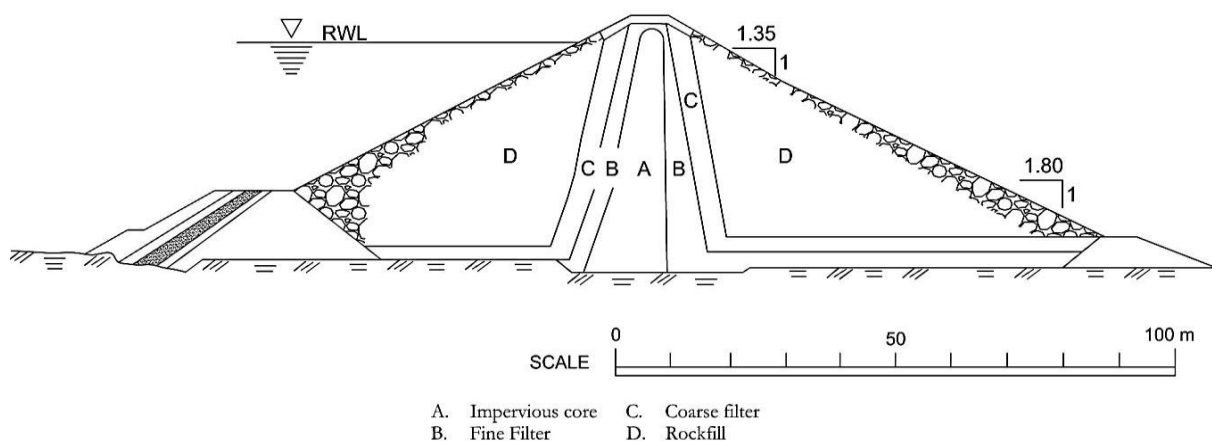

Figure 6-4: Ajaure Dam, Sweden – Typical Cross Section

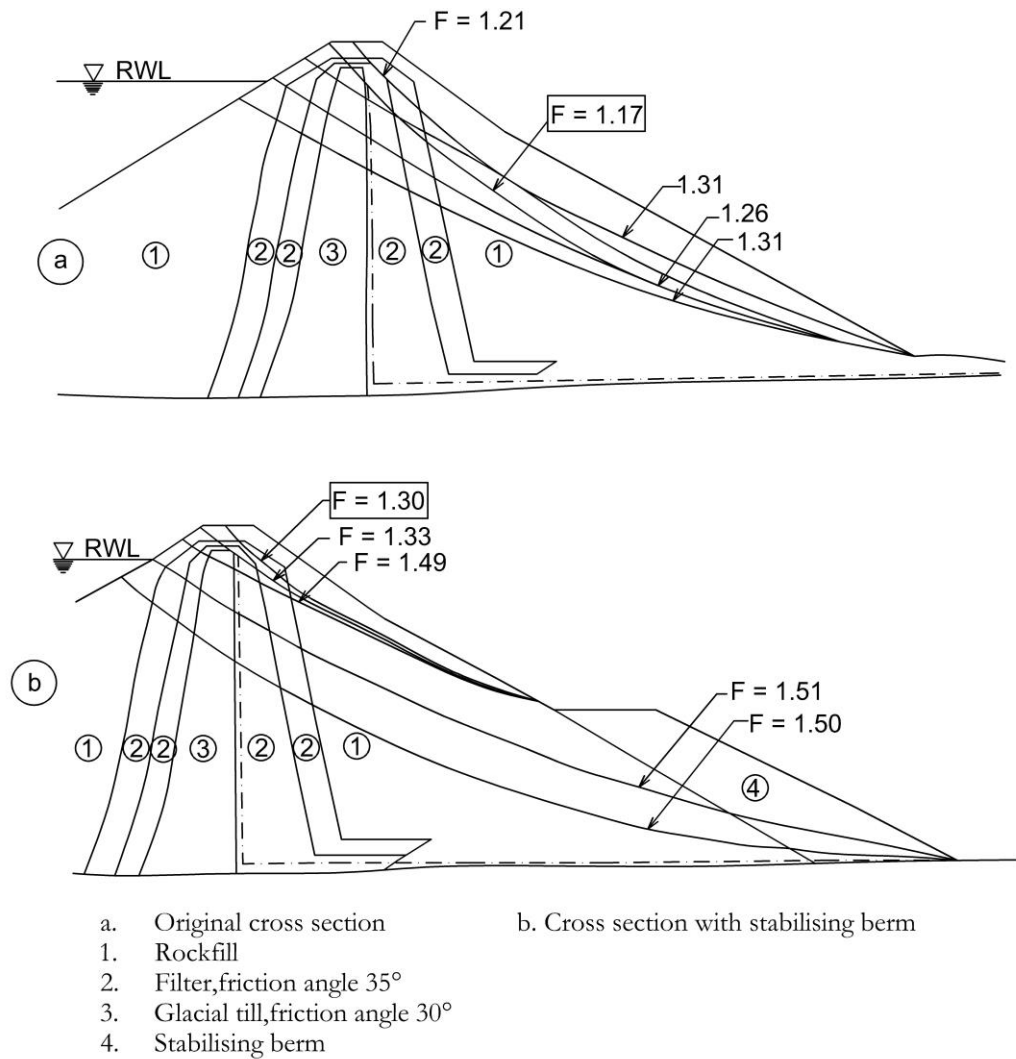

Figure 6-5: Ajaure Dam, Sweden – Influence of d/s berm on factor of safety

## 6.7 Rehabilitation to Enhance Resistance to Seismic Effects

Well-built earth fill dams have been shown to be capable of withstanding massive earthquake shaking with no detrimental effect. Worldwide, only about a dozen are known to have failed completely as the result of an earthquake. These dams were primarily tailings or hydraulic fill dams, or old small earth fill embankments. A few embankment dams of significant size have been severely damaged, some of which were close to failure, and were replaced (ICOLD 2011a, 2011b, 2013; USCOLD 1984, 1992, 1999).

Earthquake shaking may cause weak materials to lose enough strength to initiate a slope failure or an undesirable deformation of the embankment. Deformation, settlement and lateral movement can result from consolidation of foundations or fill materials. Differential deformation of adjacent materials, for example, abutments and structures, may develop fissuring, allowing internal erosion to start. The settlement might be enough to allow overtopping.

Rehabilitation or upgrading of an embankment dam due to this reason will depend upon the materials used, quality of construction of the embankment and the materials in the foundation. If liquefaction is apprehended a site-specific seismic study may be required.

### 6.7.1 Rehabilitation Measures

To rehabilitate an earth dam to improve its stability under earthquake shaking, one must either change the engineering properties of the dam and foundation, alter the geometry of the existing dam, or both (Marcuson et al. 1993). Berms and buttresses are used to increase the effective overburden pressure on a problem material and thus decrease its liquefaction potential. This increase in overburden pressure causes a small amount of consolidation and thus improves the void ratio. Berms and buttresses also increase the length of the probable failure surface besides adding a counterweight to limit movement. Dulce Dam in USA (Scuero and Vaschetti 1998) is an example where the weak material was replaced with one not prone to liquefaction, a procedure that is often expensive and operationally difficult. Dewatering is always needed.

In-situ densification can be used to decrease the potential for liquefaction by reducing the void ratio of the problem material. The method includes dynamic compaction, compaction grouting, and displacements techniques. In-situ densification is most effective when the material to be improved is close to the surface and contains little silt or clay.

In-situ strengthening may envisage construction of displacement piles, stone columns, and deep soil mixing. Deep soil mixing can be implemented for thick deposits. Caution is needed when the technique is used at an existing structure because of the possibility of differential settlement.

Grouting of the foundations through the embankment needs to consider the possibility of hydraulic fracture in the embankment and that it is not easy to decide to what extent the grout will penetrate the zones needing improvement.

Drainage relieves seismically-induced pore water pressure. Techniques include strip drains, stone columns, and gravel trenches.

Drains added for rehabilitation reduce the length of seepage flow paths, which in turn increase the hydraulic gradients under static pool conditions. Hence, even if the drains are designed as filters with respect to the adjacent material, the static safety of the dam is reduced, and more water may seep through the dam.

## 6.8 Rehabilitation of Upstream Faces

Rehabilitation of upstream face will normally require lowering of the reservoir level for the purpose. Further works below MDDL and above river bed will need to be very carefully planned and shall be of highly specialized nature, being under water.

Materials used to form an impermeable upstream face of an embankment dam include concrete, asphalt, timber, steel, clay and geo-membranes. The most often used, at least up to recent times, are asphaltic concrete and reinforced concrete. Geo-membranes are becoming more popular and, as noted above, the innovative techniques being developed to allow rehabilitation to be carried out under water can only accelerate this (Scuero and Vaschetti 1998).

### 6.8.1 Asphaltic Concrete Faces

Asphaltic concrete has been used as the impervious element of many dams. It is particularly popular as a lining to the upper pond in pumped storage plants, where the frequent and rapid rate of the rise and fall of the water level is an important ageing factor. Among the causes of deterioration of asphaltic concrete faces are oxidation and brittleness under the influence of atmospheric oxygen combined with sunlight and hot temperatures. Such a brittle material is less able to resist the fluctuating stresses. Early designs incorporated two impervious bituminous layers. Air bubbles sometimes developed at the interface, leading to deformation and cracking of the asphalt surface. Vertical joints between strips carried out by finisher equipment are prone to rapid

deterioration if they have not been carefully executed.

Rehabilitation of asphaltic concrete facings requires specialist contractors. The work often involves the removal of ageing and damaged asphaltic facings and their replacements with new bituminous layer & mastic coating. The Markersbach and Hardap Dams (Frohnauer and Torkhul 1996) fall into this category. It has sometimes been found that a repair using a geomembrane is more economical. Sa Forada dam in Italy (Scuero et al. 1998) and Moravka Dams in Czech Republic (Brezina et al. 1998) are typical of this approach.

### 6.8.2 Concrete Faces

Concrete faced rockfill dams have been used successfully since the middle of the twentieth century. Earlier designs were based on dumped rockfill. This was replaced in the 1970s by compacted rock fill. Rehabilitation may be necessary when the concrete face is unable to accommodate the settlement of the rock-fill. The excessive settlement of the rock-fill may be due to lack of stiffness or due to the effects of lack of free draining characteristics. Problems met include cracks on the concrete face, water-stop failure and spalling at joints.

Courtright Dam (100 m high) in the United States, built in 1958, was one of the last of the dams to be designed using dumped rock-fill. Early in the 1970s, the dam began to show distress including open, offset joints resulting in unacceptable leakage. Reconstruction of the upstream face was undertaken (Kollgaard and Chagwick 1998).

The 71-meter-high Gouhou dam (concrete faced gravel structure), in China, is an example of the failure of a dam of this type (Chen, 1993). Immediately after the dam was completed in 1989, when the water was still 22 meters below the standard retention level, a concentrated flow appeared on the downstream slope near the toe and started

to scour the embankment material. The scour damage was repaired, and the leak seemed to stop. An inspection following an earthquake in 1990 revealed no cracking or leakage. Further concentrated flows appeared later in 1990 and were repaired by lowering the water level. In 1993, the reservoir reached its highest level. Within a day, water was seen gushing out of the downstream face. Witnesses reported a thunder-like noise and saw water splashing and stones rolling down the central part of the dam. The failure of the dam was attributed to water leaking through cracks in the slab of the crest wall when the reservoir level was only 300 mm above the elevation of the cracks.

Repairs to damaged concrete faces have been tried using both geo-membranes (Brezina et al. 1998) and asphaltic concrete.

## Chapter 7. REHABILITATION OF APPURTENANT WORKS

The scope of this chapter is the rehabilitation of appurtenant works of dams which is required because of the effects of ageing and due to the changes in standards worldwide with time. The appurtenant works include spillways and outlet structures together with their energy dissipaters, gates and the associated mechanical and electrical control equipment.

The life span of electrical and mechanical equipment for operation and control of dam projects is much shorter than the main structural components of the dam. The life span of mechanical & electrical plant is normally 30-40 years. On the other hand civil works can be expected to have a useful life of over 100 years. Mechanical wear, environmental impact and especially corrosion are major reasons for this, in addition to poor maintenance. More refurbishment work is needed on the appurtenant elements than on the main structure of the dam. Gates and control equipment's often have unacceptable wear and tear and may need to be repaired periodically. There may also be essential items like steel conduits, pipes that are difficult to inspect and may require construction of cofferdams.

### 7.1 Principal Causes of Deterioration

#### 7.1.1 Local Scour

Scour occurs due to the inter-action of fast flowing or turbulent water with natural materials like rock and soil in rivers/channels. The effect of impact, turbulence, and friction is to generate hydrodynamic forces against the faces exposed to the flow. Often these forces are not well understood, not properly accounted for and underestimated. As a result, hydraulic structures are sometimes under-designed in this regard and suffer considerable damage as a result. Damag-

es to stilling basins at Libby dam & Dworshak dam in USA occurred due to pulsating hydrodynamic pressures. These days hydrodynamic pressures in a stilling basin are considered for the design of anchors below energy dissipaters as per IS 11527 - Criteria for structural design of energy dissipaters for spillways

Erosion downstream of a hydraulic structure is a result of local scour. Spillway structures discharging high flows with large velocities can result in large scouring downstream. Suitable precautions are necessary by way of provision of a cut off/key of suitable depth at downstream of the energy dissipater to avoid propagation of scour below the main dam structure. Structures on sand or soil foundations like barrages or at fall locations in spill channels for spillways located in flanks etc. are also vulnerable to the erosion of the foundation. Also unlined chute spillways are prone to erosion/scour.

The potential erodibility of rock can sometimes be determined by precedent. However, erodibility is dependent on the geotechnical properties of the rock mass. A close study of the geology is essential to ensure sliding stability of dam along weak features especially where the rock foundation adjacent to spillway structure is eroded and the weak features are daylighted.

The technique of calculating stream power and comparing this with the Kirsten index appears to provide a useful tool for assessing erodibility (Van Schalkwyk et al. 1994).

#### 7.1.1.1 Detection and Monitoring

Scouring is a complex phenomenon, and there are at present no analytical and experimental methods for forecasting scouring phenomena definitively. Physical Hydraulic

Model Studies can be used in estimation of scour depths. There are empirical formulae also to assess scour depths in literature which can also be used.

Periodic visual or sounding surveys and underwater inspections by divers are useful in figuring out the extent and development of the scoured area. These inspections may have to be scheduled during non-monsoon periodically when there are no flows over the spillways. In some structures changes in normal operations may also be required to permit the surveys.

In the most severe cases, erosion downstream can undermine a major structure, causing structural collapse.

#### 7.1.1.2 Rehabilitation Measures

Rehabilitation measures against erosion include two broad approaches. First to remodel the works/topography downstream of energy dissipaters by way of removing obstruction to flows due to which return/unfavorable flows take place & their by improving the flow conditions. Second is to provide suitable protection works or to fill the erosion cavities with material more resistant to the eroding process.

In case of flip buckets these days plunge pools are being pre-formed to control hazardous scour.

#### 7.1.2 Erosion by Abrasion

Solid particles like suspended silt, rolling boulders, logs etc in the flowing water during monsoon can cause significant erosion by abrasion in hydraulic structures. The extent of damage is a function of velocity and turbulence in the flow as well as the hardness of the abrasive material and the quality and nature of the surface being abraded. Spillways, stilling basins, bucket types energy dissipaters, barrages, outlets etc. are particularly vulnerable to abrasion damages.

In India Maneri dam & Ichari dam, Uttarakhand which are both being rehabilitated under DRIP are examples of abrasion damages.

Asymmetric flow can also be major contributor to the problem, as brought out in the case study of Uljua Dam (Kulkarni et al., 1994).

Three principal sources of abrasive material are reported. The first is due to the suspended sediment & sometimes rolling boulders which come along with flood waters & flows over the spillways, outlets etc.. Abrasion in energy dissipaters is also caused by rock drawn into them, especially in case of roller bucket (slotted roller or solid roller bucket) from downstream by reverse currents, unfavorable downstream topography etc. A third source is a material that finds its way into stilling basins, tunnels or pipelines by other means, such as, construction or maintenance debris, fallen rock from side slopes etc.

There are reported cases of damage from abrasion at a discharge much smaller than the design discharge, for example in Seyhan Dam (Orhan 1994) particularly when a high tail water level causes a hydraulic jump to form on a sloping chute approach to the flat floor of the stilling basin. There is also a problem just downstream of flip buckets in which the low flows fall and erode the foundation just downstream of the structure. As such protection works viz. RCC apron is often necessary adjacent to the bucket. (Refer IS:7365 Criteria for hydraulic design of bucket type energy dissipaters).

Some stilling basins designed to form a hydraulic jump or Roller Buckets (Solid/Slotted) tend to draw rock and sand from the downstream channel back into the energy dissipator and continue to circulate the material rather than eject it or sweep it from the basin. This circulation of sand and rocks is like the action of a ball mill, causing severe erosion of floors, side walls, floor



blocks, and the bucket teeth. The depth of erosion may reach meters (ICOLD 1994).

Damages to low-level outlets and temporary diversion outlets have been reported in the conduit lining, gate and valve parts, and pipes. Particularly vulnerable are outlets used for diversion during construction, bottom outlets or outlets designed for the control of reservoir sedimentation.

Once damage to concrete or steel surface has started, the abrasion accelerates with each operation of the spillway or bottom outlet. Hydraulic cavitation may also be triggered by the abrasion damage, increasing the rate of destruction.

#### 7.1.2.1 Detection and Monitoring

Regular inspection of stilling basins and low-level outlets is the only reliable means of detecting the extent of the damage. Underwater inspections have also been conducted. A case history is Potomac River No. 5 Dam (McClain et al. 1994). Abrasive damages can occur rapidly under high flow conditions.

#### 7.1.2.2 Effect on Safety and Performance

Abrasion action causes erosion of a concrete surface, first eroding the cement paste surrounding aggregates. Sometimes the exposed aggregates are damaged or detached from the surface. As the process develops, the concrete may be eroded down to the reinforcing steel. The process can, over time, lead to a catastrophic failure.

On metal surfaces, the abrasive action can result in insufficient material thickness of remaining material to perform the design intent. The abrasive action causes erosion of surfaces which under high-velocity flows will also be more vulnerable to cavitation and there by result in rapid damages to the surface.

#### 7.1.2.3 Repair of Damaged Surfaces

Rehabilitation options for structures suffering from abrasion damage fall under three broad categories: 1) repair of the damaged surfaces, 2) redesign to prevent the flow conditions responsible for the damage and 3) improved operating techniques.

Abrasion damage can be repaired and minimized by constructing flow surfaces of special high strength concretes or resistant materials such as stainless steel. Natural materials are often useful, particularly cut stone blocks of high-quality igneous rock (Kogovek 1997). Such blocks of stones have been successfully used in Dakpathar, Virbhadra and Asan Barrage in Uttarakhand. However, these solutions are expensive and do not eliminate the cause. In the design of these facilities, it would be ideal to exclude the abrasive content of the flow as far as possible. However this is normally impracticable. The power outlets are normally provided with sedimentation basins and are often required to be closed whenever the silt concentration in water during monsoon is high.

The use of high strength concrete and other resistant materials is normally recommended for the repair of heavily eroded areas. Silica fume in conventional concrete is an effective means of improving the resistance to erosion by surface abrasion. This extremely fine silica powder creates a hard and durable cementing paste in the concrete. Paste or mortar in concrete is susceptible to erosion by wear. Excellent quality hard aggregate will resist wear better than conventional aggregates. The combination of high-quality aggregate in silica-fume-modified concrete produces a harder and more durable material better suited to severe erosion environments. The High Performance Concrete (HPC) used for erosion resistance has been discussed at para 4.4.1 in detail.

The performance of calcium aluminate cement and calcium aluminate aggregate are reported by Cabiron (1996) and Cabiron and

Lavignes (1998). Cylinder compressive strengths of 50 MPa in 24 hours are reported, and the resulting material has shown in tests to be an effective repair material with excellent adhesion and durability under severe abrasion coupled with high water velocity.

Toyoda et al. (1991) report test results that show the resistance of a range of materials to attack by gravel. These showed that even high strength concrete can get eroded much faster than stainless steel and suggests that in the most severe cases more expensive solutions may be called for.

Under the DRIP, the repairs to spillway profile and slotted roller buckets of Maneri dam & Ichari dam in Uttarakhand are being carried out with high strength concrete. The detailed case history of Maneri dam has been covered in case histories under Appendix A.

### 7.1.3 Erosion by Cavitation

Cavitation is one of the most frequent causes of deterioration of high-head spillways and outlet works. Cavitation occurs in flowing water when a reduction of pressure within the water leads to a change of phase from liquid to vapor. The process starts with development of gas nuclei. The gas nuclei may grow rapidly, forming visible cavities in the fluid. As the local velocity increases, the pressure decreases proportionally, and it may reach a critical value at which the vapor cavities become unstable. The cavities collapse when they move into an area where the pressure is greater. The collapse of the cavities generates intense pressure shock waves, which produce noise and surface damage. The pressure bursts may reach thousands of MPa. The cavitation damage itself may produce a region of reduced pressure leading to further cavitation.

In hydraulic structures subjected to large flow velocities, pressure reduction is primarily caused by changes in the local velocity caused by boundary irregularities. The most

vulnerable area for outlets is the region where pressure flow changes to free-surface flow. This is normally downstream of a control gate or valve that discharges into a free-flow conduit, tunnel or a chute. Aeration is provided at such locations by suitably designed air vents.

#### 7.1.3.1 Detection and Monitoring

Cavitation risk is usually based on the evaluation of the critical cavitation index, and its comparison with the cavitation number for the flow. Empirical expressions for the calculation of critical cavitation index are available in the literature. Such expressions were obtained by evaluating laboratory tests on flows across diverse types of surface irregularities including gate slots. The cavitation number for the flow depends on open channels or unpressurized tunnels on the vapor pressure, the steepness of the chute bottom, the radius of the vertical bend and water depth normal to the flow (Jansen, 1988). The cavitation number for the flow through gates depends on vapor pressure, water pressure and flow velocity at the critical location.

The potential for cavitation damage can be evaluated for existing hydraulic structures by measuring the pressure profile and comparing the local pressure with the water vapor pressure. Such field tests are applied during the phase of the design of corrective action for damaged structures. For practical purposes, the critical pressure for the onset of cavitation may be taken as the vapor pressure of the fluid. If the pressure within the flow fluctuates, there may be increased risk of cavitation, even though the mean pressure is well above vapor pressure.

As a rule, if the velocity of the stream entering a stilling basin exceeds about 20 m/s, the flow near baffle blocks may cavitate.

IS:4997 – Criteria for design of hydraulic jump type stilling basins with horizontal and sloping apron specifies that if the flow velocity is more than 15 m/s then the basin

blocks should not be provided in a stilling basin.

Cavitation will be a serious possibility when the velocity exceeds about 25 m/s. Tunnel spillways have been shown to be particularly susceptible to cavitation and care needs to be taken with both changes of grade and concrete finish to avoid creating zones of low pressure. Aeration devices are now included in spillways where velocities may exceed 20 m/s. The cavitation in the stilling basin of the Pit 6 Dam has been discussed by Cassidy (1994). Rehabilitation works have been carried out to take care of cavitation damages in Glen Canyon Dam (USCOLD 1996) and Karun No. 1 Dam (Fouladi 1994).

### 7.1.3.2 Effect on Safety and Performance

The effect of cavitation on concrete and steel surfaces can be unexpected, rapid and disastrous. Within a single event, spillways have been destroyed, and valves or outlet works made inoperative. An extreme example of the destructive force and speed of cavitation is found in the outlet at Tarbela Dam in Pakistan (Lowe et al. 1979). The flow velocity at which cavitation damage became significant was about 47 m/s in the tunnels.

### 7.1.3.3 Rehabilitation Measures

Aeration of high-velocity flow has been proven to be the best method for the prevention of cavitation. Thus, the design of new structures should include aeration provisions to prevent or minimize cavitation damage.

IS: 12804 - Criteria for estimation of aeration demand for spillway & outlet structures can be referred to in this connection besides other specialist literature.

Existing structures that have been damaged by cavitation erosion may be retrofitted with aeration devices. In retrofitting structures with aeration slots, concrete may have to be

dismantled/excavated. However, concrete excavation can be reduced using ramps to create a space for introduction of air.

The use of smooth walls and cavitation-resistant covering, for example, high strength concrete, fiber concrete or steel can help in avoiding cavitation problems. Zhang (1994) has described work of this nature at Sanmexia Dam in China. However, it is better to remove the source of the cavitation than to try to prevent damage that the problem causes.

In areas subject to erosion by cavitation and abrasion, the use of special concrete or other materials should be considered. Concrete made of calcium aluminate aggregate and cement has been shown to be effective in resisting the effects of cavitation on concrete.

Fiber reinforced concrete includes between 0.5% and 1.5% by weight of cement of steel or polypropylene fibers. This amounts to about two million fibers per cubic meter of concrete. These fibers increase the toughness and tensile strength of the concrete. Impact resistance and fatigue strength are also improved. However, fiber-reinforced concrete is not as resistant to erosion by large water velocities as special concrete or blocks of igneous rocks. This is attributed to the grinding action of the sediment particles entrained in the water, coupled to flexure of the fibers leading to local damage of the surrounding concrete. Under cavitation conditions, the evidence is conflicting as to whether fiber-reinforced concrete is effective in reducing damage.

Patching can be used to correct damage from cavitation or erosion, fundamental tolerance errors, concrete form bolt holes, and lift-joint imperfections. In recent years, superior materials and procedures have been developed.

The patching material must be prepared for the needs of a given situation, and it must

be properly applied and cured. Mirza and Durand (1994) report on a series of tests of repair materials and methods.

There is no simple solution for repairs. In some circumstances, the solution is to use concrete of the same quality as the surrounding material and held in place monolithically. For this the repair material should have the same texture and thermal expansion/contraction characteristics as the surrounding material. However, even similar concrete placed after the original concrete has gone through its drying shrinkage can pull away from the base material as it cures. The designer may have to vary the properties of the patch material to account for this.

It is not necessarily true that high compressive strength means a better material. Crushing by compression is seldom the mode of failure in an environment of cavitation erosion. Failure is more often related to the dimensional stability, tensile capacity, fatigue endurance, strain capacity, and continuity of the repair material with parent material.

Epoxy resin is an excellent repair material, and yet many repairs made with epoxy resin have later failed. Investigation of failures has shown that the epoxy did not fail, but that the repair system did. That is, the epoxy itself held up well and was bonded to the concrete, but a separation occurred just below the glue line. Differing shrinkage or thermal properties can contribute to this occurrence. It also can be caused by vapor or water pressure building up beneath the epoxy, causing it to spall off along with the weaker concrete matrix just beneath it. In other cases, the epoxy repair has resisted the cavitation forces but transmitted them to the base material without redistributing them sufficiently for the core concrete to withstand them.

Monomers and polymers offer possibilities for repair work in concrete (Lampa, 1994). This type of material can also be used in original construction, to increase resistance

to damage in areas where cavitation is known to be possible, or where expensive consequences are expected if damage did occur.

In new construction, the monomer can be soaked into the hardened concrete after moisture is force-dried out of the capillaries. It then is polymerized or solidified in situ. The resulting strength of the concrete and its resistance to cavitation can be significantly increased. The repair of Libby and Dworshak Dams used epoxy, fiber reinforced concrete and polymerized concrete (Regan et al. 1979).

It is imperative to mention here that the various repair materials like High Performance Concrete (HPC), cementitious mortar, epoxies, steel liners, etc. have been discussed along with their advantages and limitations in detail in Chapter 4 i.e. "Material for Rehabilitation".

#### **7.1.4 Obstruction by floating Debris in the Flow**

A frequent problem with overflow spillways and low-level outlets is the obstruction of the discharge by debris. This scenario has the most severe consequences when the spillway or the low-level outlet become inoperable. Trash racks can be damaged and the operation of gates and valves impaired by the debris.

Floating blockage can be a problem for overflow spillways. Logs can get stuck in partially open gates or in the gate/stoplog slots and prevent operation. Floating debris can also damage gates by physical impact.

Low-level outlets may be blocked not only by timber but also by sediment. Case histories of such rehabilitation works are Holmstyes Dam in the United Kingdom by Dyke et al. (1998) and Allos Dam in Spain by Uceda et al. (1996). Clogging is more likely in small outlets that are infrequently operated. Extended periods of time without

operation may allow the openings to become permanently blocked and many lead to the loss of the facility. Silt accumulation in gate slots is a common nuisance. Valves that block the flow passage, such as butterfly valves and cone valves, appear to suffer more from blockage than valves or gates that expose the whole cross section.

#### **7.1.4.1 Detection and Monitoring**

The blockage of a spillway is often detected visually. Low-level outlet blockage is detected by the failure of the outlet to work. Frequent operation of gates and valves is recommended.

Siltation within a reservoir can be monitored by the survey of "silt lines" or by the observation of siltation at selected points. This is typically done using a Global Positioning System (GPS) to locate the points and soundings to measure the depth.

It is important to watch catchment conditions to predict when debris load is likely to be a problem. Forest fires can add significantly to the problem.

#### **7.1.4.2 Effect on Safety and Performance**

In the most severe cases, the spillway capacity may be reduced below the design requirement so as to endanger the dam from relatively small floods. Siltation or submerged debris may make bottom outlets inoperable and prevent the lake from being lowered in an emergency.

#### **7.1.4.3 Rehabilitation Measures**

The corrective action used for blockage prevention includes two broad approaches: 1) removal of the solid material, or 2) adding measures that prevent it from obstructing the opening. Routine maintenance is an essential activity.

## **7.2 Rehabilitation of Outlet Works**

The operation of a dam depends on its outlet or control works to achieve its purpose of supply of water for irrigation, water supply, power generation etc. Typically, each outlet consists of an intake structure through which the stored water enters the outlet, a tunnel or a pipeline to convey the water and a powerhouse inlet valve or pressure dissipating valve.

Most of the operating components of outlet works (trash screens, control gates/valves, control systems) have a significantly shorter life than other elements of a dam. This is usually recognized at the design stage and facilities are incorporated to simplify replacement or repair. In some structures, the replacement method envisaged by the designer may require the water level to be lowered, often considerably. The loss of water and the resulting loss in revenue has encouraged many dam owners to seek solutions that do not need the reservoir water level to be lowered during the repairs.

Bottom outlets or scour outlets, where the intake is submerged by a considerable depth of water, pose a problem because of a significant amount of water loss, the time needed to lower and refill the reservoir, and sometimes the impracticability of doing this with uncontrolled inflows. A problem is the economic cost of the loss of water when the reservoir is emptied. This has prompted creative rehabilitation solutions to outlet works in which the work is done with the reservoir full.

Care is required in planning and carrying out work by divers. Even a water flow velocity of 2 m/s can make conditions extremely hazardous.

Provision of emergency gates/stop logs is generally made to facilitate repairs of service gates.

### 7.2.1 Outlet Tunnels and Conduits

The largest outlet tunnel repair was that undertaken at Tarbela Dam (Pakistan) where 382,000 m<sup>3</sup> of low strength concrete had to be placed in Tunnel No. 2 alone before construction of a new lining could begin (Chao 1980).

If there is cracking in the RCC outlet conduits it can be attempted to grout the cracks by a suitable grout material approaching from the d/s side with the main service gate in lowered position when the reservoir levels are low.

Sometimes rehabilitation of outlet conduits can be carried out by installing a small diameter sleeve within the existing outlet and grouting the annulus and the cracks in the outlet structure. All technologies used in conventional water pipeline replacement can also be considered, where feasible.

The design of high-head outlet conduits needs care. For long conduits, the downstream head loss will ordinarily produce the required back pressure to prevent cavitation, but for short conduits, gate passages often must be enlarged or exit constriction provided to generate appropriate pressure conditions. When conduits are flowing with entrance gates partially open, aeration from properly designed air vent is necessary because the back pressure will not be applied when the conduits flow partly full.

### 7.2.2 Bottom Outlets

The cavitation on bottom outlets can be minimized by the application of some or all of the following design features:

- Improving the shape of water passages. Examples are streamlining of conduit entrances, increasing the amount of offset and decreasing the rate of taper downstream of gate slots, or using larger bend radii.

- Increasing the pressure by raising the hydraulic grade line in areas of disturbed flow, which may be carried out by flattening any downward curve, restricting the exit end of the conduit, or increasing the cross-sectional area in such localities as gate passages to decrease the velocity and increase the pressure.
- Introducing air into low-pressure areas not only to raise the pressure but to introduce air bubbles into the flow that will inhibit the formation of cavitation pockets and cushion the effects of their collapse.

Proper design of the rehabilitation works reduces the probability of major problems occurring. Large clear openings are required. Radial gates or slide gates are preferred (Lefranc et al. 1994). Trash racks, if they are used, should have a clear area of 60% to 90% of the opening. If hollow jet valves are used, narrow trash rack spacing is necessary to prevent the valves themselves from blocking.

#### 7.2.2.1 Operation and Maintenance

Clogging of low-level outlets can be averted by suitable operation procedures in which the outlet valves or gates are routinely exercised, and the accumulation of debris near the outlet is removed. It is sometimes possible to flush debris through the openings. Emptying the reservoir is usually not an economical option, and underwater work by divers is required. Detailed collaboration with specialized divers is needed especially when there is a danger of underwater mudslides, or when they are working at depth.

Minimizing debris can be achieved by complete removal of vegetation from the bed of the reservoir before it is filled and periodic use of dredgers to remove sediments near the intake and the outlet. It also includes the use of dredgers to remove sediments near the intake of the outlet. Combined with the management of the catchment to prevent

debris from entering the reservoir, this can reduce the risk of blocking of the outlet.

However small size low level river sluices (outlets) have not been very successful in Indian conditions as the sediment load is large & often it is not possible to operate such outlets if they are not operated regularly. Perhaps regular dredging of the intake area needs to be studied, where necessary.

### **7.2.3 Rehabilitation of spillways and energy dissipaters**

The safety of the dam depends upon the proper functioning of the spillway during floods in monsoon. Hence regular examinations and maintenance are essential if the failure of the structure is to be prevented and costly repairs are to be avoided.

Seyhan Dam in Turkey, built in 1956, is an example of erosion that became so severe as to threaten the safety of the dam itself (Orhon 1994). The dam was designed with a chute spillway with a terminal flip bucket. The spillway discharged small discharges over long periods during its first years of operation. The hydraulic jump occurred on the spillway chute channel causing severe structural damage. Clogged drainage underneath the spillway slab contributed to the generation of uplift pressures at the damaged area. A second erosion mechanism was also discovered. The water spilling over the spillway flip bucket at low flows eroded the riverbed just downstream the spillway and endangered the foundation of the structure.

After the damages to the stilling basins of Libby & Dworshak dams in USA due to hydrodynamic pressures, the stilling basins in our country are also being designed for the same. Procedure for considering the hydro-dynamic pressures in the design of stilling basins is given in IS 11527 - Criteria for structural design of energy dissipaters for spillways.

The stilling basin provided in Sardar Sarovar dam & Tehri Dam are 6 m and 10 m thick respectively. Both have been designed for hydrodynamic pressures.

Further in some recent Indian dams aeration arrangements have been provided in spillways to safe guard against cavitation damages. In both Tehri and Sardar Sarovar dams aeration arrangements have been provided.

Under the DRIP many of the damaged spillways, energy dissipaters & fall structures in the spill channel of flank spillways are being rehabilitated.

Extensive damages had occurred on the spillway crest/glacis & bucket of Maneri Dam & Ichari dams of Uttarakhand. They are being repaired with High Strength Concrete of M90 grade (both with & without fibers) in case of Maneri dam where the damages are extensive primarily due to rolling boulders & sediment carried by the flowing water during monsoon.

In Ichari dam the damages were repaired with special mortar & M60 concrete as per the thickness of damaged area. For the repairs of abraded piers/walls, special mortars with high compressive strength have been used. In all cases bonding agents are being applied along with anchors etc. for bonding.

In Almatti dam, Karnataka, there were extensive damages to stilling basin which are being repaired with normal concrete underneath & M60 concrete on top.

In some dams like Narayanpur Dam, Karnataka, concrete aprons/protection works have been provided downstream of the flip bucket for lesser discharges.

In many dams having flank spillways there were a lot of damages in the fall structures, training walls etc. in the spill channel. They have been suitably repaired/reconstructed. In some cases pilot channels downstream of the main energy dissipaters have been wid-



ened to the width of the spillway to improve flow conditions & reduce scouring.

Case histories of repairs of stilling basins of Bhakra dam and Sardar Sarovar dams have been included in Appendix A.

### Improving Flood Capacity

Over time, the estimates of inflow design floods have increased and larger spillway capacities are required.

In the Indian context the inflow design flood to be considered is determined based on hydraulic head & gross storage at FRL in accordance with IS:11223 Guidelines for fixation of spillway capacity.

The assumptions used to determine the design flood are continually being questioned. Faced with the requirement to make dams safe in conformity with current practices the dam owners are examining both structural & non-structural options for the purpose.

The common options that emerge from a study of the available modern case histories show that the following modifications are typical:

- Raising the height of a dam in view of higher maximum reservoir level.
- Constructing one or more additional (auxiliary) spillways, fuse plug/breaching sections, flush bars etc..
- Provision of solid parapet wall on the upstream at dam top (where not available) provided that it is able to provide for the revised freeboard requirements.
- Strengthening the crest and downstream face of the embankment to allow some overtopping
- Collecting more and better data to give advanced warning of adverse conditions and to monitor the response of the dam and reservoir.

- Lowering of the reservoir operating level to increase the flood storage volume.
- Modifying catchment flood characteristics by building flood detention devices or even an upstream dam.
- Increasing dam stability to accommodate higher flood water levels with cable anchors and mass gravity structures.

Further two or more dams located near one another in a series on the same river (a cascade of dams) are common at many locations in India. It is usual to consider the effect of the entire cascade in the revised design flood. From techno-economic consideration it may be desirable to increase storage and attenuation at one reservoir, thereby avoiding enlarging spillways at those downstream. However this exercise is required at planning stage at the time of construction.

Care must be taken with gated structures so that adequate provisions are available to ensure that gates can be opened in an adequate amount of time during a flood when power may not be available. Operator trainings are absolutely necessary. Communication systems have often failed in an emergency emphasizing the need for effective training to ensure that operators can work effectively in isolation.

Under the DRIP it has been seen that the revised flood has increased in 183 dams out of 223 dams. Flood routing studies have been carried out to arrive at the revised MWL. Various structural & non-structural measures are being considered for the deficient dams.

The structural measures under consideration are:-

- (i) Provision of additional spillways
- (ii) Provision of flush bars & breaching dykes.

- (iii) Increasing the dam height
- (iv) Provision of downstream solid parapet walls.

The non-structural measures under consideration include:

- (i) Lowering of the FRL
- (ii) Flood Forecasting
- (iii) Emergency Action Plan (EAP)

### **7.2.4 Protection of Abutments**

The abutments of a dam may also need to be strengthened to resist the higher water loads associated with revised MWL due to review of inflow design flood. The consequences to the valley slopes of the overtopping flood water need to be considered.

Repairs made at Gibson Dam (USCOLD 1996) to remedy this situation are typical. This is an arch gravity concrete dam 61 m high in USA, completed in 1929 and modified in 1982. It is classified as a high hazard dam. Flooding on June 8 and 9, 1964 overtopped the dam. Overtopping exceeded 1 meter over the parapets and lasted for about 20 hours. The intent of the modification was to allow safe overtopping of the dam during floods greater than the 1% annual probability event (that is, the 100-year return period flood). The modification included treatment of abutments by installation of rock bolts and concrete cladding to protect the rock downstream of the abutments from detrimental erosion during overtopping. In addition, splitter piers along the downstream parapet provided aeration during over-topping and minimized the risk of damage from an unsteady flow.

Morris Shepherd Dam, USA is a flat-slab-and-buttress concrete and embankment dam, 47 meters high, completed in 1941 with a high hazard classification. It was modified in 1988. Evidence of downstream movement of the main dam was discovered in 1987. The horizontal movement, which was measured to be about 110 mm, was

found to originate from a slide along a weak seam in the clay shale foundation. Further investigations also found high uplift pressures in the impervious and weak foundation rocks. Cracks were found in a transition beam along four bays. It was estimated that both the concrete and the embankment sections would be overtopped during PMF.

Grouting of cracks and other parts led to a reduction in seepage and a decrease in the piezo-metric pressures. A new emergency spillway was constructed, and the service spillway was reconditioned (USCOLD 1996).

## **7.3 Rehabilitation of Gates and Other Discharge Equipment's**

### **7.3.1 General**

The mechanical and electrical equipment's are an essential part of a dam project. Indeed, it could be argued that this equipment provides the necessary control for which the project was built. However, the life of the mechanical and electrical plant is usually not more than about 30 or 40 years with regular maintenance. Therefore, its timely repair & upkeep plays an important part in the rehabilitation of a dam. The civil works can be expected to have a useful life of well over 100 years with proper maintenance, and it is expected that the mechanical plant will be rehabilitated more than once in the life of the project. The problems experienced by hydro-mechanical equipment that limits its life are caused by the joint effects of regular wear & tear, corrosion, erosion and poor maintenance. The key to prolonged trouble free operational life, is to follow sustained and well planned routine services as well as the occasional break-down interventions for maintenance, with-out any time gape.

Replacement/Rehabilitation of gates & valves is generally required after a service life of around 30 - 40 years although there are no hard & fast yard sticks for the same.

Planned inspections at regular intervals followed by maintenance or upkeep of the Hydro-Mechanical (H.M) works above the water level as well as underwater through professional divers or automated R.O.V videos becomes essential for the longevity of the H.M equipment's.

The design aspects, operation and maintenance of Hydro-Mechanical works including gates and hoists of various types are well described in the various Indian Standards as well as in manuals of CWC and CBIP. Accordingly these aspects are not covered here.

A regular schedule of operation, inspection and maintenance restores the damages and deficiencies to a great extent and postpones the requirement of rehabilitation by extending its useful life.

Aspects like maintenance requirements; safe operating procedures etc. need to be documented in operation & maintenance manuals.

The aging gates deteriorate faster and such installations need to be monitored for their strength more often, especially if the installations are more than 30 years old. Before executing the rehabilitation of aged gate installations, assessment of the deterioration of the gate structure needs to be monitored with reference to its original design parameters. The integrity of the gate under question is required to be assessed by measurement of thicknesses of skin plate, horizontal girders, and vertical stiffeners etc. after removal of rust, scales etc. by grit/sand blasting. The digital ultrasonic instruments are available for such measurements. Having established the structural weaknesses, process of strengthening the structure is proposed for restoration of its strength to withstand safely the water pressure and hydrodynamic forces encountered by the structure.

Appropriate painting procedures are adopted to control corrosion and loss of thickness

so that the structure can perform its functions as planned/designed.

### 7.3.1.1 Basic concerns

These are as under:

- Non-availability or deficit of trained manpower at site, design departments etc.
- Financial restrictions on budgets for maintenance & rehabilitation.
- Irregular & unplanned system of servicing, maintenance.
- Non-availability of design, drawings, O&M manuals at site.
- Non-availability of maintenance closure provisions for gates.
- Contractors with inadequate resources and facilities at sites.
- In-effective and irregular inspections, inadequate preventive maintenance at sites.

### 7.3.1.2 Priorities in rehabilitation works

The rehabilitation works should first deal with the critical works needed to make the structure safe and operable.

In this context it is essential that all the spillway gates are kept operable from considerations of dam safety. It is also well established that aging gate installations are more prone to deteriorate fast and require significant work of periodical inspection, maintenance, and rehabilitation.

### 7.3.1.3 Upstream Closure Facility

The dam planners/owners are increasingly equipping the dams with adequate provision of isolation equipment's (stop logs, emergency gates etc.) right in the planning stage of the project for maintaining the operational reservoir pool levels.

Where such provisions are not provided, any inspection, repairs, maintenance works generally require lowering of reservoir levels with loss of benefits during the closure period.

Further a thorough inspection, maintenance, rehabilitation of gates are best performed in a dry, dewatered state with safe & effective access to all the component parts, especially those requiring regular servicing, maintenance, & replacements. The easy, safe, approach, with accessibility on demand serves as a timely, cost effective, result oriented, process of servicing & maintenance with reduced overall cost, worker safety, and improved work quality.

A very recent incident of failure of the Spillway gate no 1 of the Krishnagiri Dam in Tamil Nadu highlights the importance of having a maintenance closure facility or the upstream isolation provision, as there was no provision for stop logs and associated equipment. In such circumstances, the reservoir water level had to be brought down below the spillway crest for cutting and taking out the failed gate.

#### 7.3.1.4 Other Technical Aspects

Some of the high head sluice gate installations experience hydrodynamic forces like down pull, up lift, vibrations, cavitation in case certain specific design provisions are ignored. Such gate installations are designed considering the location of bottom most girder, and are provided with suitable bottom lip and need provision of proper air vent etc. Controlling the hydrodynamic forces and their impact like vibrations etc. on the gate installation is the subject of research and is covered in various publications like ICOLD (1996).

Such gates and valves highlight the importance of model testing to control such hydrodynamic forces by provision of proper inlet profile, gate slot and outlet geometry, smoothness of surfaces and alignment to avoid consequences of deficient hydraulics.

The gate installations of many of the scouring sluices/river sluices remain non-functional for longer spells as these generally face regular onslaught of silting, trapping of boulders/stones/debris in the gate grooves, especially if the openings of these sluices are small in size. Small sized sluices are therefore not recommended. Such installations require special features like provisions of bottom lip, air vent requirement, & experience down pull, uplift, vibrations, pulsating flow, air entrainment requirements etc. Such installations thus need special features like bottom lip, location of the bottom girder, diverging intake shape, converging outlet shape, model study requirement for computing uplift and down pull forces etc.

The following aspects need special attention:

- (i) Provision of bell mouth for streamlined flow entry, provision of air vents to avoid negative pressures.
- (ii) Provision of stainless steel/steel liners to provide strong surface for passing high velocity sediment laden flows to avoid abrasion of concrete etc.
- (iii) Provision of hydraulic hoist, power packs, for providing a positive thrust under high head operations to overcome the opposing forces for perfect closure
- (iv) Provision of bonneted construction to isolate the operating gallery from the ingress of water for safety.

#### 7.3.2 Rehabilitation works including inspections/monitoring

The rehabilitation process involves a thorough examination, inspection of the equipment integrity in stationary state, running state on no load, running state on load to identify the problem areas, deterioration, and damages required to be attended by carefully observing & diagnosing the problem areas by observing its functioning critically by a or group of specialists capable to

interpret & decipher the problem areas by witnessing its functioning, observing various indicators like sound / noise, & other indicators during such investigative trial runs.

Major rehabilitation works involving replacement of damaged parts & components replacement of installations etc. are being carried out at work sites by developing temporary site workshops by the contractors. Generally it is not possible at site to completely replicate all the desired facilities of a well-established fabrication workshop equivalent to that existing in an industrial estate. Therefore the quality of fabrication at site will always be considered as not equivalent to the quality of work executed in a proper workshop with all facilities & competencies. However it becomes helpful to manufacture the new gate installation at site with already installed embedded parts and gate features available & measurable for reviewing during the construction to suit the requirements of the as built embedment of the gate.

These observations lead to subsequent processes of dismantling the assemblies/sub-assemblies for their close examination of the wear & tear, deterioration, damages to make an assessment and undertake the renewal/replacement works and rectify or replace the deteriorated components.

### 7.3.2.1 Old and aged gate installations

Many hydro-mechanical equipment's (gate and hoist systems) commissioned in past are likely to be nearing or might have even past their useful designed life. Such installations shall be requiring replacement of their critical components, proper servicing & overhauling etc. Many of these may be found requiring updation on account of having been designed based on obsolete past design guidelines, standards which are not likely to meet the provisions subsequently introduced in the extent design specifications and design criterion, as the design standards regularly get updated due to availability of new technological advances, improvements

in materials, the updated properties like wear and tear, fatigue, factor of safety, etc.

There is also likelihood of emergence of new knowledge areas, techniques, materials, availability of updated literature or standards, through ongoing research & development, knowledge acquisitions, improved guidance on load cases and allowable material stresses, improved software support practices bringing about improved life, quality, enhanced corrosion / wear protection properties, low maintenance requirements with better performance parameters. The rehabilitation of old aged installations need to consider such improved, techniques and design practices as far as practically possible.

### 7.3.2.2 Dam safety review panel inspection

Dam safety review panel recommendations are generally used to finalize the scope of work of rehabilitation & modernization services.

Multi-disciplinary dam safety review panels are constituted for detailed inspection and through on-site assessment of the structural adequacy of dam facilities, installations and equipment's. The recommendations of such designated D.S.R.P.'s become the basis of intended scope of work for execution of the required repair, maintenance, replacement or rehabilitation exercise by the concerned dam owner. He has to plan, design, prepare estimate for the rehabilitation works based on:

- Inspections & Assessment of structural adequacy of Civil, H.M & Electrical works.
- Evaluation of physical state of civil, electrical and mechanical equipment & installations along with their underwater components like embedded parts etc., for firming up refurbishment and redevelopment activities by dam owners.

The participating execution/bidding agencies should have a relevant and varied experience in the condition assessment, monitoring and rehabilitation of masonry/concrete structures and hydro-mechanical works and the electrical facilities, with sufficient experience in design, manufacture, erection/ installation of rehabilitation works of similar facilities. The rehabilitation agency should have a thorough understanding & experience relevant to the work and should have the requisite infrastructure and qualified and experienced engineering executives and workers with requisite expertise.

### 7.3.2.3 Underwater Inspections for embedded parts

The underwater inspection of embedded parts for establishing their integrity, reusability and the necessary strengthening & improvements for trouble free extended service, especially for sluice gate installations are possible as per following methodologies:

- Inspection & videography of critical components by deploying services of divers though having many limitations like safety limit of water pressures for divers, turbid water posing problems of clarity, inaccessible areas due to limited access, limitations of diving duration etc., but is still the most commonly prevalent means for assessment of deterioration & damages to the underwater components and embedded parts up. The rectification of damages can be planned and executed by the divers deploying underwater cutting & welding technologies. This procedure has certain limitations like depth of water, safe period of divers availability under water at one go.
- The latest available technology of R.O.V (Remotely operated vehicle) deployment is also now available for inspection as well as for attending to some of the intended rectification works at much deeper depths and even in constricted areas for the re-

medial processes to set right the deficiencies & defects of underwater components.

### 7.3.2.4 Recommended in-situ monitoring aspects of old & used Gates & Hoists

The old and aged gate installations need to be monitored for safety aspects due to various types of deterioration, defects and weaknesses induced in various components.

Aspects like servicing and painting can carried out during operation and maintenance.

The level of stresses in certain sensitive components like radial gate anchorages etc. require to be monitored to identify the areas of concern to be taken care during the rehabilitation process.

The old gates posing threat to d/s population & infrastructure need to have a proper monitoring intervention and usage of instrumentation for periodic assessment of stress levels of sensitive components of the gate structures by provision of following and alike instrumentation:

- i) Strain gauges at appropriate locations of the most stressed components or on the weakened and deteriorated components. For radial gates, it must be provided for monitoring the stress level in tie flats, junction of horizontal girders & skin plate etc.
- ii) Similarly for fixed wheel gates these may be used especially in monsoon season to monitor stress levels at junction of horizontal girders & skin plate, or other higher level stress points.
- iii) The three dimensional stress level can also be monitored by photo elastic tests of a complicated multi-joint location like tie flat joint with yoke girder etc.

### 7.3.3 Investigations/testing before rehabilitation works - Integrity Review Protocol Requirements

Review of structural integrity along with other Nondestructive tests for checking the integrity or weakness of various structural steel members of old and used gates, welding, painting and stationary & rotating components of hoists like rope drums, shafts, plumber blocks, wire ropes, motors, brakes, couplings, gearings, and components by some or all of the following:

- Visual inspection & measurement of critical components.
- Digital Ultrasonic thickness gauging,
- Dye penetrant testing for surface cracks & defects,
- Ultrasonic flaw detection for internal defects,
- Magnetic particle flaw detection for surface and welding defects,
- Radiographic internal flaw detection,
- In-situ metallurgy of the components,
- Surface hardness testing of components.

#### 7.3.3.1 Visual inspection & measurement of critical components

This shall include checking rusting, scaling and weakening of all component parts of the gates and hoist. Cleaning including removal of rust and scale layers etc. from the structural and other metallic surfaces by sand paper or by mechanical tools etc. for baring the metallic surface of flakes of rust and scales etc. for preparing it for dimensional check of thickness measurements, checking welded, bolted/riveted joints for their physical wellbeing and integrity etc. and creating detailed records of visual inspection. The bigger surfaces like skin plates, horizontal girder/channel sections etc. are divided in small rectangular grids for

noting down the averaged thickness dimensions for comparing with the designed section thicknesses deciding on the repairs for bringing this back in good acceptable shape and form.

Similar action is required to be checked for cracks and weaknesses, if any, the fillet and butt welds for strengthening the weakened welds as well other bolted or riveted joints by repair or replacement of the component parts.

#### 7.3.3.2 Measurement of Dimensions

Following (Figure 7-1) are some of the essential instruments for measurements of dimensions of the critical locations, measurement of dimensions, alignment etc.

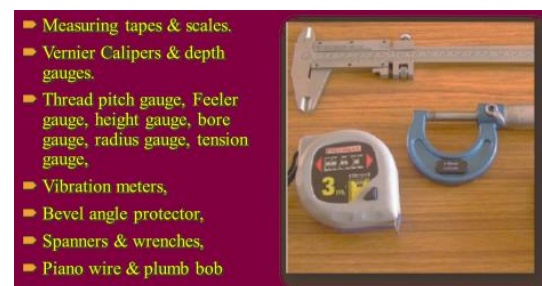

Figure 7-1: Routine Site Instruments, Tools for H.M Works

#### 7.3.3.3 Digital Ultrasonic thickness gauging

The thickness aspect is further reconfirmed by mechanical means or more accurately by ultrasonic tests. For large surface areas like that of skin plate a grid of rectangular areas are formed by marking to measure the thicknesses in these grids for averaging or deciding upon the rectification requirements.

#### 7.3.3.4 Magnetic particle flaw detection for surface and welding defects

For detection of surface cracks in steel structure components, weld joints etc. Dye Penetrant & MPT tests are conducted. Such checks are performed on the gate, embedded parts, hoist platforms, and hoist components.



### 7.3.3.5 Ultrasonic flaw detection for internal defects

For internal metallic defects in structures, shafts, castings, gear etc. ultrasonic scan serves to indicate internal flaws like voids, blow holes etc. in metallic components.

### 7.3.3.6 Radiographic internal flaw detection

The radiographic flaw detection tests are generally prescribed for full strength welds, and in critical components of the gates and hoists.

### 7.3.3.7 In-situ metallurgy of the components

For aged gate & hoist components for which the material specifications are not known due to non-availability of specifications and drawings, these tests are performed to ascertain the metallurgical composition.

### 7.3.3.8 Surface hardness testing of components

The surface hardness tests are required to ascertain the surface hardness treatment requirements of components like wheel tracks, wheel rims where the documentation is not available for proposing replacement materials for wheels & tracks etc.

## 7.3.4 Protection Measures

### 7.3.4.1 General/P.P.E Requirements

- Ensure personal protection equipment (P.P.E) availability at site for workers, namely helmets, welding goggles, hand gloves, insulated T&P for electrical works, safety belt, rain coat, gum boot etc.
- Advise the site engineers to make it a customary practice to go for a cursory daily inspection of gates

and hoists to rule out any unusual happening.

- Check with site engineer, in regards to any deficiency, problem, difficulty faced during the operation.
- The site problems noticed or brought out during the site inspection visit.

### 7.3.4.2 Personal Protective Equipment

- Personal protective equipment (PPE) refers to protective clothing, helmets, goggles, or other garments or equipment designed to protect the wearer's body from injury or infection. The hazards addressed by protective equipment include physical, electrical, heat, chemicals, biohazards, and airborne particulate matter.
- The law requires employers to provide their employees with safe and healthful workplaces.

#### Examples:

- Safety spectacles/Goggles/Welding shields,
- Helmets, hard hats.
- Gum boots/safety shoes.
- High visibility reflective safety work wear.
- Protective gloves/wears/rain coat etc.

## 7.3.5 Checks before and after rehabilitation

### 7.3.5.1 Vertical Lift Wheeled Gates (Figure 7-2)

- Check surface cracks on steel works & on surrounding concrete works, especially in load bearing locations & welds.

- Check all bolts & nuts are tight (Loosened bolts & nuts need to be tightened.)
- Check cracks damages like boils or blisters in painted surfaces.
- Check surface cracks on steel works & on surrounding concrete works, especially in load bearing locations & welds.
- Check all bolts & nuts are tight (Loosened bolts & nuts need to be tightened.)
- Check cracks damages like boils or blisters in painted surfaces.
- Accumulation of water & silt on horizontal girders & other members of the gate structure, ask the Project to provide drain holes, if not provided or these need to be enhanced in numbers or size at appropriate location Check surface cracks on steel works & on surrounding concrete works, especially in load bearing locations & welds.
- Check all bolts & nuts are tight (Loosened bolts & nuts need to be tightened.)
- Check surface cracks on steel works & on surrounding concrete works, especially in load bearing locations & welds.
- Check all bolts & nuts are tight (Loosened bolts & nuts need to be tightened.)
- Check cracks damages like boils or blisters in painted surfaces.
- Check surface cracks on steel works & on surrounding concrete works, especially in load bearing locations & welds.
- Check all bolts & nuts are tight (Loosened bolts & nuts need to be tightened.)

- Check cracks damages like boils or blisters in painted surfaces.
- Accumulation of water & silt on horizontal girders & other members of the gate structure, require providing drain holes, if not provided or these need to be enhanced in num-



Figure 7-2: Vertical Lift Gate

bers or size at appropriate locations.

- Gate operation for lifting & lowering cycles is seen. Notice if the movement of gate is smooth or jerky & without vibrations.
- Downstream side of skin plate T-members of radial gates- watch that inside faces of T-beams are painted, as such difficult locations (or painting) are generally left out for surface preparation as well as painting.
- Check free rotation of wheels of vertical lift gates by hand movement.

#### 7.3.5.2 Radial Gates & Hoists (Figure 7-3 & 7-4)

- Check seals for damages, damaged/loose seal bolts & nuts, missing seal portions for replacement by a new set of seals & fasteners
- Check for any damage to lifting attachments, pulleys and pins
- For ongoing structural steel fabrication/welding works, arrangement of

NDT tests like Dye penetrant, Magnetic particle, tests for crack detection on structural fabrication work as well as on welds be insisted

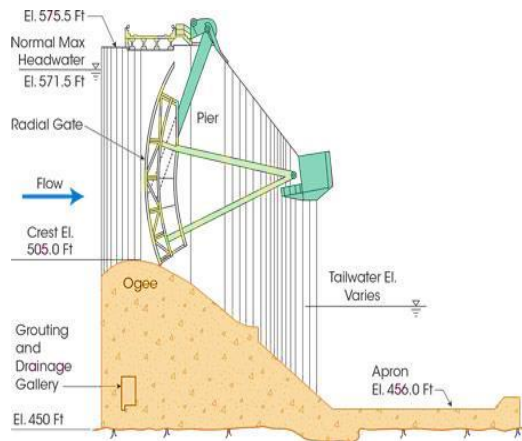

Figure 7-3 Spillway Radial Gates – Cross Section



Figure 7-4: Spillway Radial Gates – Downstream Elevation

### 7.3.5.3 Mechanical Rope Drum Hoists - Wire Rope (Figure 7-5)

- Inspect the wire rope for wear and tear, the rope strands for cracks, broken & damaged wires, visible oxidation/ rusting. (Minor oxidation to be removed by cleaning & application of Cardium compound).
- Check that the cardium compound is applied to the rope & it is not in dry condition.
- Check trash, sediments and any foreign material sticking to the

lifting rope and lifting attachment for cleaning.

- If the wear and tear / broken wires are found to be more than permissible or marked corrosion is noticed, project should be advised to get it replaced.
- As per normal practice the application of cardium compound, is to be done at least twice a year, once before the monsoon & the other after the monsoon.
- Besides, it should also be done whenever the wire rope is found to be dry.
- Adjust the rope tension of wires, if both side ropes are found unequal.
- Check all greasing points like trunnions, gear trains/ gear boxes, wheels etc. for re-greasing.
- Check the expansion provision in case of independent unbonded anchorages.
- Hoist Platform & Mechanical Hoists:
- Check all approach ladders, walkways, hand railings, rung ladders, chequered plates are not badly rusted & are of good strength & safe for usage.
- Check the condition of Motor, Brake, gear boxes, Electrical panel, rope drum, etc. for cleanliness, serviced/un-serviced condition

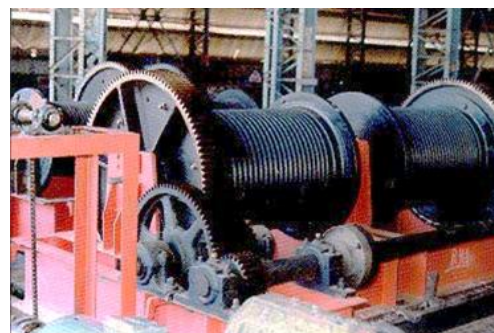

Figure 7-5: Rope Drum Hoist

- Check oil level in gear boxes and get it noted for replenishment wherever required with oil of proper grade.
- Check for Lubrication of all bearings, bushings, pins, linkages, etc.

#### 7.3.5.4 Gantry Crane (Figure 7.6)

Following aspects need to be considered and attended to during maintenance;

- Oil level in the gear boxes. It is very important to ensure that the correct oil level is maintained. Over filling causes overheating and leakage, therefore, care should be taken that the breather holes are not clogged by any foreign material like dust, paint etc.
- The insulation resistance of motor winding. In case it is found to have dropped below a prescribed value, the motor should be dried prior to putting back in service. If weak insulation becomes a regular feature, the winding should be given a good coat of insulating varnish after the motor has been dried.
- Checking of all the electrical connections.
- Lubrication of each part of crane
- Removal of any loose/foreign material along the rail track
- Actuating tests of limit switches
- Actuating tests of brakes.
- All fuses in the control panel should be checked and if necessary it should be replaced.
- Necessary terminal connections of motors, brakes etc. is to be checked.
- Overload relay should be checked.
- Visual inspection of wire ropes for any snapped loose wire and its proper lubrication.

- Checking of rope clamps on the drum and tightening of bolts if required.
- Gearbox assembly should not have any leakage of oil.
- Unusual noise/vibration if any should be checked and rectified before operation



Figure 7-6: Gantry Crane

#### 7.3.5.5 Mechanical Hoists

- Check all the fuses on power lines for damages, if any and ensure closure of panel board covers to avoid entry of dust and moisture.
- Check all bolts and nuts on gear boxes, hoist drum and shaft couplings for tightness.
- Check that the starters should be cleaned & free of moisture and dust.
- Check all the geared couplings are greased.
- Check bearings for damages;
- Check gears and pinions for damage;
- Check Plummer blocks for damage;
- Check for any painting damage.

#### 7.3.5.6 Surface Preparation – Process details

- Hand Tool Cleaning-Specification St 2 (Removal of loose rust and loose paint by hand brushing)



- Power Tool Cleaning-Specification St 3 (Removal of loose rust and loose paint by Power wire brush)
- Brush off Blast Cleaning-Specification Sa 1 (A rapid Blast Process to remove loose rust and loose paint by impact of abrasive Propelled through nozzle)
- Commercial Blast Cleaning-Specification Sa2 (Careful sand Blasting to remove loose mill scale, rust and

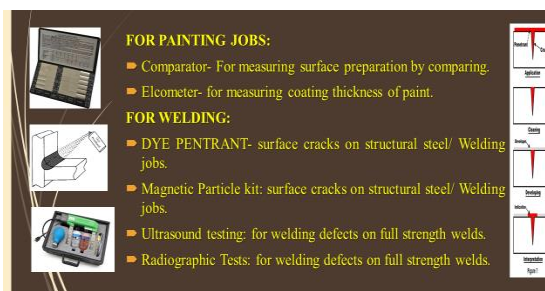

Figure 7-7: Inspection tools at site  
(paint)

- Near White Blast Cleaning-Specification Sa 2 1/2 (Sand Blasting is to be carried out for time enough to assure the removal of loose materials)
- White Metal Blast Cleaning-Specification Sa3 (Careful Blasting for complete removal of all loose material)
- Prepared surfaces are compared with the representative photographic examples as available in ISO 8501-Comparator.
- Hydro mechanical equipment's are normally sand blasted to the surface equivalent to SA 2 1/2 according to ISO: 8501.
- Surface preparation is measured by comparing the achieved surface with comparator surface.

### 7.3.5.7 Painting

One coat of primer is to be applied just after the sand blasting to avoid rusting of the blast surface due to oxidation.

### (a) Surfaces which do not to come in contact with water

The surfaces which are not in contact with water are to be applied with one coat of inorganic zinc silicate/zinc chromate of about 40-50 micron dry film thickness followed by 2-3 coats of synthetic enamel paints totaling to about 175 micron.

### (b) The surfaces which come in contact with water

Surfaces which are to come in contact with water are to be applied with one coat of inorganic zinc silicate primer of about 50 micron followed by 2-3 coats of coal tar epoxy paint totaling to about 350 micron.

Dry film thickness of the paints is measured with the help of the instrument called Elcometer

## 7.3.6 Photographs of some recent case histories

### 7.3.6.1 Krishnagiri dam- spillway vertical lift gates (Figure 7-8 & 7.9)

Basic information

Name of the dam	Krishnagiri Dam
Location	Periyamuthar Village, in Krishnagiri District
River	Pennaiyar
Type of Dam	Composite Dam
Period of Construction	1955-1957
Commissioned for Irrigation	1958 onwards
Total Length of Dam	1003 m (Masonry - 290 m & Earthen - 713 m)
Capacity at FRL	47.18 Mcum
No. of Spillway Gates	8 Nos (Vertical lift gates)
Size of Spillway	12.19 m (W) x 6.10 m (H)
No. of Sluices	River Sluices – 3 Nos. & Canal Sluice – 2 Nos.
Size of River Sluice	1.52 m x 1.82 m
Size of Canal Sluice	1.52 m x 1.82 m
Maximum Discharge	4271 cumec (Original) 5103 cumec (Revised)

### 7.3.6.2 Narayanpur Dam, Karnataka

The aged worn out spillway gate installations are being strengthened in localized areas by replacement of worn out sections or strengthening of the horizontal girders and the vertical stiffeners etc. (Figure 7-10).

The Zinc metallizing treatment is being undertaken in the following sequence:

- Strengthening of the gate horizontal Girders / vertical stiffeners.
- Sand blasting / Copper slag blasting
- Zinc metallizing (200 micron)
- Application of Zinc Primer (40 Micron)
- Application of Epoxy Coal-tar Paint (2 coats of 100 micron each)



Figure 7-8: Before Rehabilitation

(Krishnagiri dam- spillway vertical lift gates)



Figure 7-9: After Rehabilitation

(Krishnagiri dam- spillway vertical lift gates)

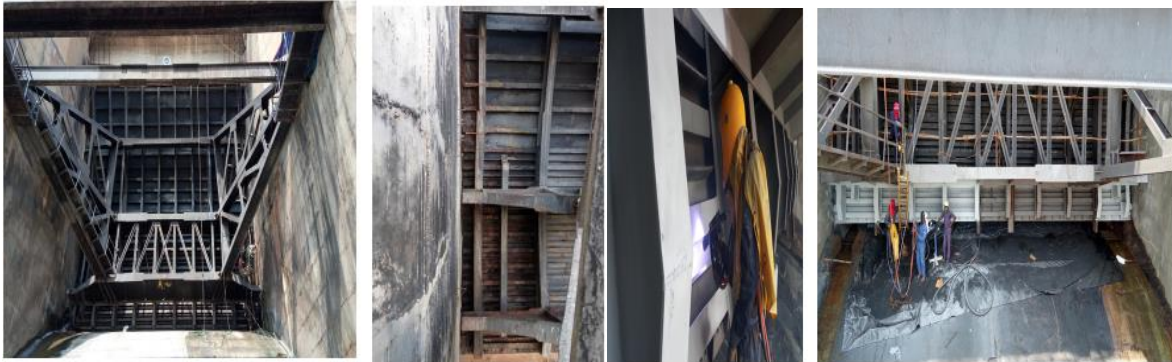

Spillway Gates before Zinc Metallizing Treatment

Additional Spillway Gates Zinc Metallizing works at downstream side



Spillway Gates Zinc Metallizing work at upstream side

Additional Spillway Gates Zinc Metallizing work at downstream side



Painting to Spillway Gates

Figure 7-10: Strengthening of Spillway Radial Gates by Zinc Metallizing

This page has been left blank intentionally.



## REFERENCES

- Beak, C., Findlay, J. W. and Alikman, D. I. (1997). "Experience of failure mode, effect and critically analysis on UK hydropower schemes." *Hydropower '97*, Proceedings of the 3<sup>rd</sup> International Conference on Hydropower, Trondheim, Norway, A. A. Balkema, Rotterdam, 369-376.
- Bister, D., Bonnet, P., Burdin, J., and Charvoz, B. (1993). Maintenance des barrages en Béton techniques et coûts." *Colloque Technique sur La Maintenance des Vieux Barrages*, Chambéry, France.
- Bister, D., Bonnet, P., Denis, B., De Beauchamp, R., Dubois, P., and Goguel, B. (1991). "Contribution au suivi des barrages en béton Français sujets a gonflement ou retrait application a des ouvrages adultes (Chambon, Vouglans) et au béton jenué (cas de BCR)." *Proceedings of the 17<sup>th</sup> ICOLD Congress*, Vienna, Austria, Q65 R7.
- Bister, D., Fry, J.-J., Costa, J. J., Houis, J., Degoutte, G., Lino, M., and Rizzoli, J.-L. (1994). "Re-assessment of earthfill and rockfill dam safety, case histories." *Proceedings of the 18<sup>th</sup> ICOLD Congress*, Durban, South Africa, Q68 R43.
- Bowles, D. S., Anderson, L. R., Glover, T. F., and Chauhan, S. S. (1998). "Portfolio risk assessment: A tool for dam safety risk management." *Proceedings of the 18<sup>th</sup> USCOLD Annual Meeting and Lecture*, Buffalo, New York, United States, 8-14 August.
- Bowles, D. S., Anderson, L. R., Glover, T. F., Tarbox, G. S., Waiter, R. B., and Yin Au-Yeung, P. E. (1990). "Evaluation of dam safety at a series of hydropower dams including risk assessment." *The Embankment Dam – Proceedings of the 6<sup>th</sup> British Dam Society Conference*, Thomas Telford, London, United Kingdom.
- BRE (1991). "An engineering guide to seismic risk to dams in the United Kingdom." *Report BR 210*, Building Research Establishment, Garston, Watford, United Kingdom.
- BRE (1988). "Alkali-Aggregate Reactions in Concrete." *Digest 330*, HMSO London.
- Brezina, P., Satrapa, L. and Skonant, T. (1998). "The reconstruction of the collapsed bituminous concrete facing of the Morvka Dam, Czech Republic." *Proceedings of the Indian National Committee on Large Dams Symposium - Rehabilitation of Dams*, 66<sup>th</sup> ICOLD Annual Meeting, New Delhi, India.
- Brighton, R. and Lampa, J. (1991). "Ageing of BC Hydro's dams." *Proceedings of the 17<sup>th</sup> ICOLD Congress*, Vienna, Austria, Q65 R 30.
- BSI (2002) "Hazard and operability studies (HAZOP studies). Application guide." *British Standard IEC 61882:2016*, British Standards Institution, London, United Kingdom.
- BSI (2006). "Analysis techniques for system reliability. Procedure for failure mode and effects analysis (FMEA)." *British Standard EN 60812:2006*, British Standards Institution, London, United Kingdom.
- Cabrion, J.-L. (1996). "Evaluation of abrasion resistant materials in hydroelectric structures. From laboratory tests to on-site appraisal after 5 years." *Proceedings of the SWEDCOLD Symposium – Repair and Upgrading of Dams*, Stockholm, Sweden.
- Cabrion, J.-L., and Lavignes, A. (1998). "Research on the use of ALAG concrete for hydraulic abrasion and cavitation protection in dam structures." *Proceedings of the Indian National Committee on Large Dams Symposium - Rehabilitation of Dams*, 66<sup>th</sup> ICOLD Annual Meeting, New Delhi, India.

- Carlyle, W. J. (1988). Wave Damage to upstream Slope Protection of Reservoirs in the UK. Proceedings of BNCOLD *Conference on Reservoir Renovation*, Manchester.
- Cassidy, J. J. (1994). "Cavitation problems at Pit 6 stilling basin." *Proceedings of the 18<sup>th</sup> ICOLD Congress*, Durban, South Africa, Q71 R6.
- Cederwall, K. and Nilsson, A. (1991). "Description of three deterioration scenarios." *Hydraulic Engineering No. 49*. Royal Institute of Technology, Stockholm.
- Chao, P. C. (1980). "Tarbela Dam – problems solved by novel concrete." *Civil Engineering*, American Society of Civil Engineers, New York, New York, United States, 50(11), 58-64.
- Charles, J. A., Tedd, P., Hughes, A. K., and Lovenbury, H. T. (1996). "Investigating embankment dams." *Building Research Establishment Report*, London, United Kingdom.
- Chen, Z. (1993). "Breaching of the Gouhou Concrete Face sand and gravel dam." *Proceedings of the International Symposium on High Earth and Rockfill Dams*, Beijing, China.
- Combelles, J., Goubet, A., Llopis, N., and Paccard, M. (1985). "Mesures destinées améliorer la sécurité des ouvrages hydrauliques des barrages." *Proceedings of the 15<sup>th</sup> ICOLD Congress*, Lausanne, Switzerland, Q59 R46.
- Combelles, J. (1991). "Ageing of dams and remedial measures – general report." *Proceedings of the 17<sup>th</sup> ICOLD Congress*, Vienna, Austria, Q65 R16.
- CWC (2014). *National Register of Large Dams*. Central Water Commission, Ministry of Water Resources, River Development & Ganga Rejuvenation, Government of India, New Delhi.
- CWC (2015). *National Register of Large Dams*. Central Water Commission, Ministry of Water Resources, River Development & Ganga Rejuvenation, Government of India, New Delhi, Delhi.
- CWC (2016). "India's ageing large dams – lessons from DRIP." *DRIP Information Bulletin No. 5, Doc. No. CDSO\_IB\_DRIP\_05*, Central Dam Safety Organization, Central Water Commission, Ministry of Water Resources, River Development & Ganga Rejuvenation, Government of India New Delhi.
- Dyke, T., and Williams, P. J. (1998). "Rehabilitation of Holmstyes Reservoir." *The Prospect for Reservoirs in the 21st Century – Proceedings of the 10<sup>th</sup> British Dam Society Conference*, Thomas Telford, London.
- Egawa K., Hibino, Y., and Yoshida, T. (1994). "Renovation of 70-year-old dam on reinforcement and application of gateless spillway." *Proceedings of the 18<sup>th</sup> ICOLD Congress*, Durban, South Africa, Q68 R56.
- Eurenius, J., and Sjödin, G. (1991). "Angående undersökning och reparation avdammskada i Grunsjöns regleringsdamm, (Investigation and Restoration of Deteriorated Zone in the Grundsjön dam)." *P5795 VBB V1AK*, Stockholm, Sweden.
- Flemming, J. H., and Rossington, D. T. (1985). "Repair of Greenbooth Dam following localized settlement in the crest." *Proceedings of the 15<sup>th</sup> ICOLD Congress*, Lausanne, Switzerland, Q59 R55.
- Fouladi, C. (1994). "Karun-I chute spillway damage and construction of a new flip bucket." *Proceedings of the 18<sup>th</sup> ICOLD Congress*, Durban, South Africa, Q71 R7.
- Froehlich, D. C., Kapoor, V. K., and Flint, E. E. (2017). "India's large dams are showing their age, Part 1: Concrete and masonry dam examples from DRIP." *Compendium of Technical Papers, Third National Dam Safety Conference, Doc. No. CDSO\_NDSC3\_COMP*, Central Water Com-

- mission, Ministry of Water Resources, River Development & Ganga Rejuvenation, Government of India, New Delhi, 3-9.
- Frohnauer, R., and Torkhul, C. (1996). "New asphaltic lining for the Rabenleite Upper Reservoir." *Strabag Brochure No. 51*, Asphaltic Concrete for Hydraulic Structures, Cologne, Germany.
- Gallacher, D., Doake, R. M., and Hay-Smith, D. (1998). "Remedial works to upstream face protection, Megget Reservoir." *The Prospect for Reservoirs in the 21<sup>st</sup> Century – Proceedings of the 10<sup>th</sup> British Dam Society Conference*. Thomas Telford, London, United Kingdom.
- Gillon, M. D., Everitt, S., and Mejia, L. (1998). "Rehabilitation of the Matahina Dam for foundation fault trace displacements." *Proceedings of the Symposium on Rehabilitation of Dams*, 66<sup>th</sup> ICOLD Annual Meeting, New Delhi, India.
- Harlan, R. C., Onken, S., Scuero, A. M., and Vaschetti, G. L. (1998). "The underwater installation of a drained geomembrane system on Lost creek dam." *Proceedings of CANCOLD Conference*, Nova Scotia, Canada.
- Hartford, D. N. D. and Baecher, G. B. (2004). *Risk and Uncertainty in Dam Safety*. Thomas Telford Publishing, London, United Kingdom.
- Hewlett, H., Boorman, L. A., and Bramley, M. E. (1987). "Guide to the design of reinforced grassed waterways." *Technical Note 120*, Construction Industry Research and Information Association, London, United Kingdom.
- Hoeg, K. (1996). "Performance evaluation, safety assessment and risk analysis for dams." *Proceedings of the SWEDCOLD Symposium – Repair and Upgrading of Dams*, Stockholm, Sweden, June 1996.
- Hopkins, J. K., Wickham, D. B., and Stirling, D. M. (1990). The use of close-range photogrammetry for reservoir embankment monitoring. *The Embankment Dam – Proceedings of the 6<sup>th</sup> Conference of the British Dam Society*, Thomas Telford, London, United Kingdom, 1647-1653.
- ICOLD (1983). "Deterioration of dams and reservoirs - examples and their analysis." *Miscellaneous Report*, Portuguese Committee on Deterioration of Dams and Reservoirs, International Commission on Large Dams, Paris, France.
- ICOLD (1985). "Filling materials for watertight cut-off walls." *Bulletin 51*, Committee on Material for Fill Dams, International Commission on Large Dams, Paris, France.
- ICOLD (1988). "Dam monitoring – general considerations." *Bulletin 60*, Committee on Monitoring of Dams and their Foundations, International Commission on Large Dams, Paris, France.
- ICOLD (1989). "Monitoring of dams and their foundations – State of the art." *Bulletin 68*, Committee on Monitoring of Dams and their Foundations, International Commission on Large Dams, Paris, France.
- ICOLD (1992). "Improvement of existing dam monitoring – recommendations and case histories." *Bulletin 87*, Committee on Monitoring of Existing Dams, International Commission on Large Dams, Paris, France.
- ICOLD (1994). "Ageing of dams and appurtenant works - review, and recommendations." *Bulletin 93*, Committee on Dam Ageing, International Commission on Large Dams, Paris, France.
- ICOLD (1996). "Vibrations of hydraulic equipment for dams. Review and recommendations." *Bulletin 102*. Committee on Vibrations of Hydraulic Equipment, International Commission on Large Dams, Paris, France.

- ICOLD (2000). “Automated dam monitoring systems – guidelines and case histories.” *Bulletin 118*, Committee on Automated Dam Monitoring Systems, International Commission on Large Dams, Paris, France.
- ICOLD (2009). “Surveillance: basic elements in a ‘dam safety’ process.” *Bulletin 138*, Committee on Dam Surveillance, International Commission on Large Dams, Paris, France.
- ICOLD (2011a). “Seismic observation of dams – guidelines and case studies.” *Bulletin 113*, Committee on Seismic Aspects of Dam Design, International Commission on Large Dams, Paris, France.
- ICOLD (2011b). “Reservoirs and seismicity – state of knowledge.” *Bulletin 137*, Committee on Seismic Aspects of Dam Design International Commission on Large Dams, Paris, France.
- ICOLD (2013). “Selecting seismic parameters for large dams – guidelines (revision of Bulletin 72).” *Bulletin 148*, Committee on Seismic Aspects of Dam Design, International Commission on Large Dams, Paris, France.
- Idel, K. H., and Rißler, P. (1982). “Einflußer Sanierungsmaßnahmen auf die Möhnenmauer.” *Wasservirtschaft*, 3(2), 130-134.
- Jansen, R. B. (1988). *Advanced Dam Engineering for Design, Construction, and Rehabilitation*. Van Nostrand Reinhold, New York, New York, United States.
- Kogovek, B., and Pirc, H. (1997). “Dam on the Sava River for nuclear power plant Kßko - monitoring and maintenance.” *Proceedings of the 19<sup>th</sup> ICOLD Congress*, Florence, Italy, Q75 R5.
- Kollgaard, E. B., and Chadwick, W. L. (1988). *Development of dam engineering in the United States*. Pergamon ISBN 0-08-034685-5.
- Kulkarni, D. N., Shukla, S. Y., and Deshpande, V. M. (1994). “Deterioration of spillway of a large dam in Maharashtra State, India.” *Proceedings of the 18<sup>th</sup> ICOLD Congress*, Durban, South Africa, Q71 R4.
- Kuusiniemi, R. (1991). “Internal erosion of the Uljua earth dam.” *Proceedings of the 17<sup>th</sup> ICOLD Congress*, Vienna, Austria, Q65 R15.
- Lampa, J. (1994). “Repairs at Hugh Keenleyside Dam.” *Proceedings of the 18<sup>th</sup> ICOLD Congress*, Durban, South Africa, Q71 R9.
- Lefranc, M., Battistel, R., Cault, J. B., and Goguel, B. (1994). Exemples d'intervention sur des ouvrages d'évacuation. *Proceedings of the 18<sup>th</sup> ICOLD Congress*, Durban, South Africa, Q71 R26.
- Lemelin, D., and Jobin, H. (1996). “Rehabilitation of a rock-filled timber crib dyke.” *Proceedings of the SWEDCOLD Symposium – Repair and Upgrading of Dams*, Stockholm, Sweden, June 1996.
- Lowe, J., Bangash, H. D., and Chao, P. C. (1979). “Some experiences with high velocity flow at Tarbela Dam Project.” *Proceedings of the 13<sup>th</sup> ICOLD Congress*, New Delhi, India, Q50 R13.
- Marcuson, W. F., Hadala, P. F., and Ledbetter, R. H. (1993). “Seismic rehabilitation of earth dams.” *Special Publication No 35 – Geotechnical Practice in Dam Rehabilitation*. American Society of Civil Engineers, Reston, Virginia, United States.
- McClain, J., Carter, B., and Hennig, C. (1994). “Underwater repairs for Potomac River Dam No. 5”. *Dam Safety '94*, Association of State Dam Safety Officials, Lexington, Kentucky, United States, 339-347.
- Megalamani, V., Niraula, S., Nambiyanna, B., and Prabhakara, R. (2017). “Rehabilitation and Improvement of ageing dams case study: Bhadra Dam.” *Compendium of Technical Papers, Third National Dam Safety Conference, Doc. No. CDSO\_NDSC3\_COMP*, Central Water Commission,

- Ministry of Water Resources, River Development & Ganga Rejuvenation, Government of India, New Delhi, 10-16.
- Millmore, J. P., Stables, J. F., and Shannon, F. E. (1998). "The rehabilitation of Luxhay Dam, Somerset." *The Prospects for Reservoirs in the 21<sup>st</sup> Century – Proceedings of the 10<sup>th</sup> British Dam Society Conference*. Thomas Telford, London, United Kingdom.
- Mirza, J. and Durand, B. (1994). "Repair mortars for controlling abrasion-erosion damage on dam surfaces." *Proceedings of the 18<sup>th</sup> ICOLD Congress*, Durban, South Africa, Q71 R12.
- Mohamed, K., Montel, B., Civard, A., and Luga, R. (1969): "Cheurfas Dam anchorages: 30 years of control and recent reinforcement." *Proceedings of the 7<sup>th</sup> International Conference on Soil Mechanics and Foundation Engineering*, Mexico City, Mexico, 167-171.
- Montfort, L., Millet, J. C., Fabre, J. P., Bordes, J. L., Euvrard, D., Ricard, C., and Royet, P. (1991). "Elements de methodologie pour la detection et l'analyse du vieillissement illustres par des exemples (Detection and analysis of ageing: parts of methodology illustrated with examples)." *Proceedings of the 17<sup>th</sup> ICOLD Congress*, Vienna, Austria, Q65 R23, 405-437.
- Nilsson, A. and Mikaelsson, J. (1996). "Groundwater pressure increase and internal erosion at Langbjorn Dam." *Proceedings of the SWEDCOLD Symposium – Repair and Upgrading of Dams*, Stockholm, Sweden, June 1996, 503-519.
- Orhon, M. and Bilgi, V. (1994). "Deterioration of spillway of Seyhan Dam." *Proceedings of the 18<sup>th</sup> ICOLD Congress*, Durban, South Africa, Q71 R10.
- Regan, R. P., Munch, A. V., and Schrader, E. K. (1979). "Cavitation and erosion damage to sluices and stilling basins at two high-head dams." *Proceedings of the 13<sup>th</sup> ICOLD Congress*, New Delhi, India, Q50 R11.
- Rißler, P. (1994). "Rehabilitation of existing gravity dams in Germany with respect to safety philosophy and economy." *Proceedings of the 18<sup>th</sup> ICOLD Congress*, Durban, South Africa. Q56 R5.
- Rißler, P. and Heitefuss, C. (1999). "Adaptation of the Ennepe dam Germany to the established technical standards." *International Journal of Hydropower and Dams*, 6(2).
- Rönnqvist, H., Fannin, R. J., and Viklander, P. (2015). "The unified plot approach for assessing internal erosion – a case study of the Grundsjön Dam sinkhole event." *Proceedings of the 25<sup>th</sup> ICOLD Congress*, Stavagard, Norway, Q98 R5, 66-82.
- Schneeberger, C. E., Pigeon, Y., Leavy, J., and Boncompain, B. (1991). "The use of slurry walls and jet grouting techniques to repair existing cofferdams at LG- 1." *Proceedings of the 17<sup>th</sup> ICOLD Congress*, Vienna, Austria, Q65 R 29.
- Scuero, A. M. and Vaschetti, G. L. (1998). "A drained synthetic geomembrane system for rehabilitation and construction of dams." *The Prospects for Reservoirs in the 21<sup>st</sup> Century – Proceedings of the 10<sup>th</sup> British Dam Society Conference*. Thomas Telford, London, United Kingdom.
- Sharma, Devendra Kumar, Suri Sanjeev and Singh C P "Under Water Repair of Bhakra Dam Spillway Apron by Pneumatic Caisson Technique" *Bhakra Beas Management Board*
- Shukla S Y and Deshpande V M (1996) "Strengthening of Structures" *Second International Conference on Dam Safety Evaluation*, Trinvendrum, India
- Sims, G. P. (1994). "Ageing of masonry dams". *Proceedings of the Institution of Civil Engineers Water, Maritime, and Energy*, 106(3), 61-70.
- Toyoda, T., and Takasu, S. (1991). "Erosion control for sediment flushing facilities." *Proceedings of the 17<sup>th</sup> ICOLD Congress*, Vienna, Austria, Q65 R20.

- Uceda, J. L., Gines, R., and Heras, E. (1996). "Conditioning, repair, and completion of the Alloz Dam," *Proceedings of the SWEDCOLD Symposium – Repair and Upgrading of Dams*, Stockholm, Sweden, June 1996.
- USCOLD (1984). "Bibliography on performance of dams during earthquakes." U.S. Commission on Large Dams, Denver, Colorado, United States.
- USCOLD (1992). "Observed performance of dams during earthquakes." U.S. Commission on Large Dams, Denver, Colorado, United States.
- USCOLD (1996). "Anthology of Dam Modification Case Histories." U.S. Commission on Large Dams, Denver, Colorado, United States.
- USCOLD (1999). "Observed performance of dams during earthquakes, volume II." U.S. Commission on Large Dams, Denver, Colorado, United States.
- Van Schalkwyk, A., Jordaan, J. M., and Dooge, N. (1994). "Erosion in unlined spillways." *Proceedings of the 18<sup>th</sup> ICOLD Congress*, Durban, South Africa, Q71 R37.
- Vaughan P. R., Kluth, D. J., Leonard, M. W., and Pradoura, H. H. W. (1970). "Cracking and erosion of the rolled clay core of Balderhead dam and the remedial works adopted for its repair." *Proceedings of the 10<sup>th</sup> ICOLD Congress*, Montreal, Canada, Q36 R5.
- Vick, S. B. G., and Stewart, R. A. (1996). "Risk analysis in dam safety practice." *Uncertainty in the Geologic Environment, ASCE Geotechnical Special Publication No. 58*. American Society of Civil Engineers, Reston, Virginia, United States, 586-603.
- Weaver, K. D., and Bruce, D. A. (2007). *Dam Foundation Grouting*. ASCE Press, Reston, Virginia.
- Wittke, W., and Greb, H. (1994). "Überprüfung der Standsicherheit der Urfttalsperre." *Wasserwirtschaft*, 84, 11.
- Xanthakos, P. P. (1991). *Ground Anchors and Anchored Structures*. John Wiley and Sons, New York, New York, United States.
- Zhang, J. (1994). "Deterioration of the bottom outlets in Sanmexia Project and abrasion of the spillways for Gezhouba Project." *Proceedings of the 18<sup>th</sup> ICOLD Congress*, Durban, South Africa, Q71 R12.

**APPENDIX A – CASE HISTORIES OF DAM REHABILITATION IN  
INDIA**



This page has been left blank intentionally.

## CASE HISTORIES OF DAM REHABILITATION IN INDIA

Selected case histories of rehabilitation efforts at some Indian dams are presented in this Appendix to illustrate latest means of repairing and upgrading dams.

### 1. CHIMONI DAM, KERALA

#### 1.1 Brief Description of the dam:

Chimoni Dam in Thrissur district of Kerala is a composite masonry cum earth dam with a total length of 1211 m. The length of masonry dam is 525 m and that of earth dam is 686 m. The maximum height of the masonry dam is about 53 m and that of the earth dam is about 30 m. The masonry spillway is of Ogee type and is operated by 4 radial gates for a design flood of 1680 cumec. The masonry dam consists of 17 blocks. The upstream face of masonry blocks has a 500-mm thick cement concrete cladding of M20 grade whereas on the downstream face it is of M10 grade. The dam was constructed during the period 1975 – 1996 and the first full impoundment was carried out in September 2005. Gross storage capacity of the dam is 179.39 Mm<sup>3</sup>.

It is a multi-purpose project and provides for irrigation, hydro-power and drinking water benefits. There is no canal system and the regulated water from the reservoir is let down in to the river through natural and existing canals for irrigation. In addition, the works for generating 2.5 MW Hydro Electric power are under progress. The project also envisages providing drinking water supply to the peripheral villages.

The vicinity map of the project is at Figure - 1 and a downstream view of the Masonry Spillway is at Figure - 2 below.

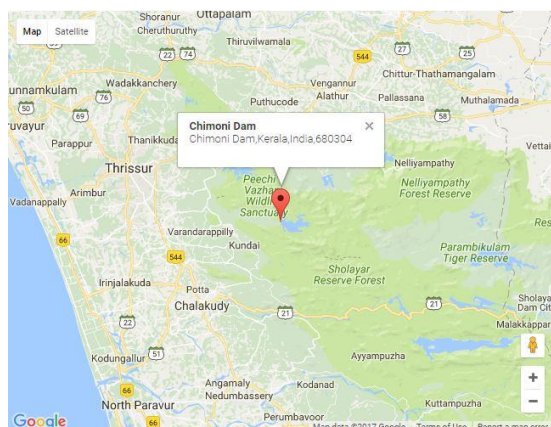

Figure - 1 Vicinity Map



Figure - 2 Down Stream view of Masonry Spillway

#### 1.2 Salient Features:

Salient Features	
Type of dam	Composite Masonry cum Earthen dam
Total length	1211 m
Length of Earth dam	686 m
Length of Masonry dam	525 m

Salient Features	
Top level of masonry dam	+81.20 m
Catchment area	72.00 sq. km.
Water spread area at F.R.L.	10.10 sq. km.
Level of Head sluice	+40.00 m
Gross Command Area	26000.00 Ha.
Culturable Command Area	13000.00 Ha.
Bed level and the rock level at the Masonry dam site	+28.38 m
Top Width of Earth dam	7.20 m
Top Width of Masonry dam	6.00 m
Max. Height of Earth dam	29.91 m
Max. Height of Masonry dam	52.82 m
Top bank level	+81.20 m
Maximum water level	+79.700 m
Full reservoir level	+79.40 m
Dead Storage capacity	6.75 Mm <sup>3</sup>
Gross Storage capacity	179.39 Mm <sup>3</sup>
Freeboard over M.W.L	1.50 m
Type of Spillway	Ogee spillway
Total length of spillway	47.50 m
Spillway Crest level	+72.20 m
Number of spillway bays	4
Type of Gate	Radial
Number and sizes of gates	4 no. of size 10 m (W) x 7.5m (H) each
Spillway Discharging Capacity	1680 cumec

### 1.3 Problems faced:

Right from the commissioning of the dam, heavy seepage had been noticed in the inspection gallery and the downstream face of the Masonry dam. Major seepages were observed above +60.00m level. The seepage was recorded as more than 30 liter/sec.

Further, the drainage holes in the dam were choked because of calcinations and the drainage gallery was flooded with water. Recommendations were made by the State Level Dam Safety Committee (SLDSC), Indian Institute of Technology, Chennai and the Dam Safety Review Panel (DSRP) from time to time.

Various Expert Panels as above inspected the dam from time to time. Some of their recommendations in respect of Masonry dam were to carry out guniting on upstream face of dam, to determine the status of Masonry dam by 'geo-physical investigation', Masonry dam body to be grouted by stage grouting from top to bottom to strengthen the dam and reduce seepages, filler materials such as sand or rock flour to be added to cement in appropriate proportion wherever the cement consumption was high, to keep record of the seepages ob-

served, to provide a toe drain on the downstream of the masonry dam, to install pressure gauges over the foundation drainage holes in the gallery for measuring uplift pressures, the choked drains be rehabilitated by water jetting/reaming after completion of grouting, fresh holes to be drilled in lieu of heavily choked drains (if necessary), etc.

As regards spillway, in addition to the above, it was recommended that the inoperative spillway gates be made operative by chipping the RCC kerb which was obstructing the lifting/movement of the gate, to repair the severely eroded spillway glacis with high strength concrete suitably bonded to the old concrete and to provide a concrete apron adjacent to the flip bucket to safeguard it against lower discharges.

It was observed that the top surface of the masonry dam had cracked at a number of places. It was recommended to remove such damaged masonry/concrete and to re-lay the same.

Further it was recommended that reservoir level be kept below FRL by 3 meters until the above works are completed. It was also decided that a non-destructive survey "Tomography" be carried out by hiring an expert agency which can map the dam section and indicate the possible areas where voids/cavities are more and grouting is required to be carried out.

In addition, it was recommended that proper electrification be done inside the gallery as well as on top of the dam, to carry out repair works to earthen dam in the right flank and to rehabilitate the emergency shutters in the sluice.

1.4 Previous Rehabilitation works carried out

Rehabilitation works at a cost of about Rs. 94 lakhs were carried out by the State Govt. from the State funds before the DRIP. The works carried out included guniting the upstream face of dam between El 55 m to 79.70 m and drilling and grouting of masonry dam between Block No. 2 to Block No. 16 in 10 m depth from the dam top.

Figure-3 shows Guniting work carried out on the upstream face of the Masonry dam. Figures- 4 to 7 show the locations of seepage from the dam body in various blocks on the downstream face.

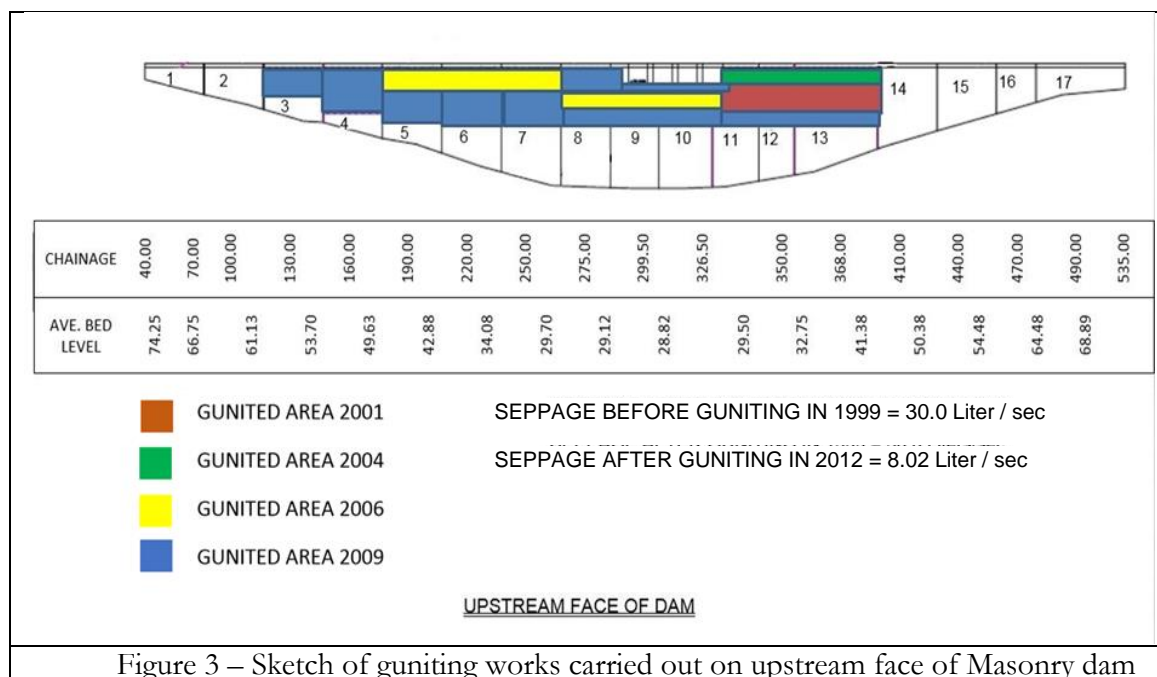

Figure 3 – Sketch of guniting works carried out on upstream face of Masonry dam

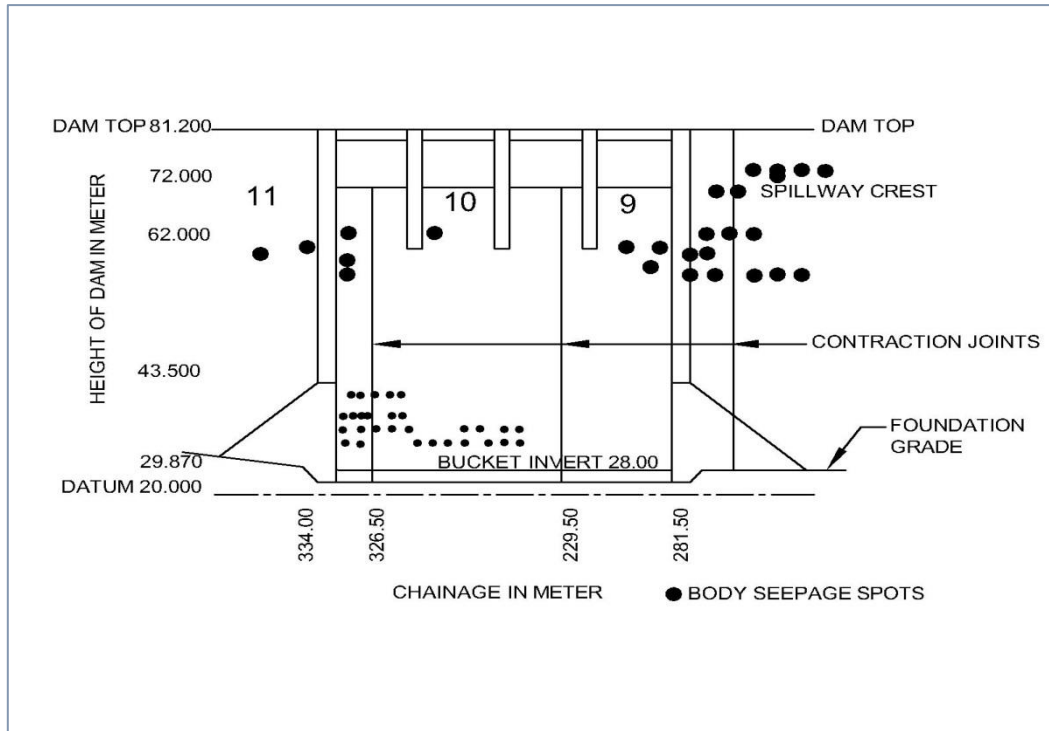

Figure 4 – Location of body seepage in Spillway Blocks no. 8,9,10 & 11 on downstream face

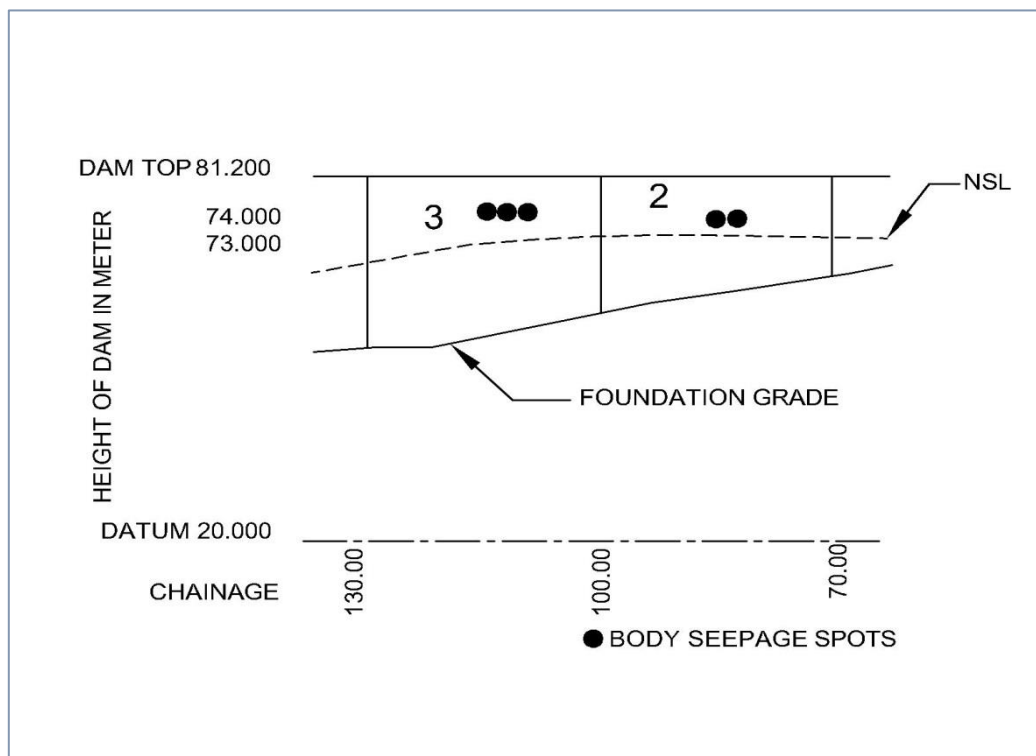

Figure 5 – Location of body seepage in Block No. 2 & 3 on downstream face

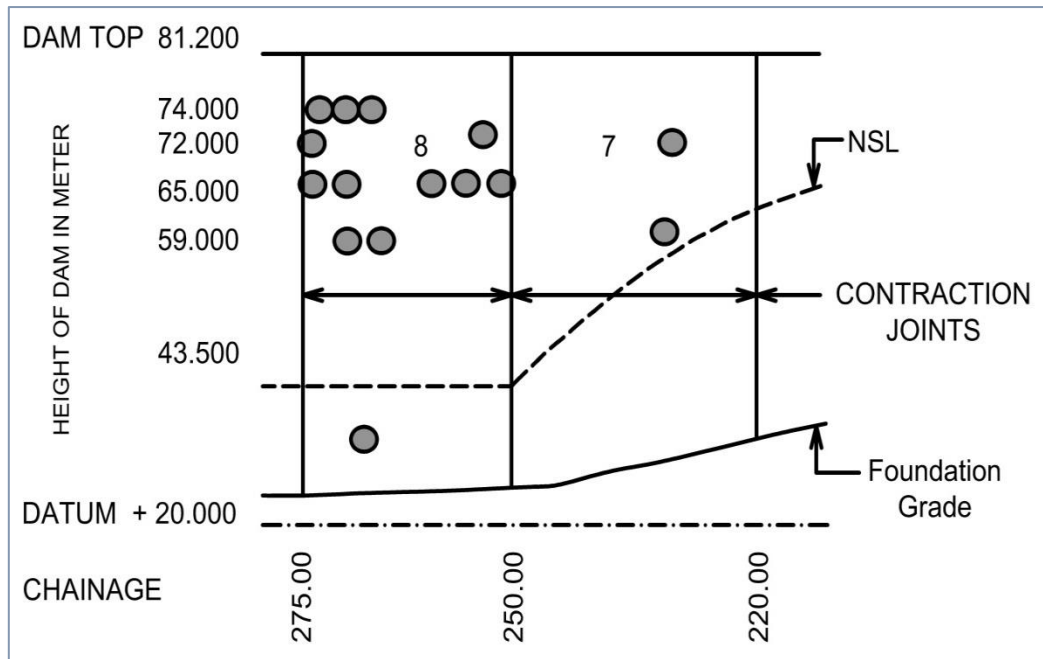

Figure 6 – Location of body seepage in Block No. 7 & 8 on downstream face

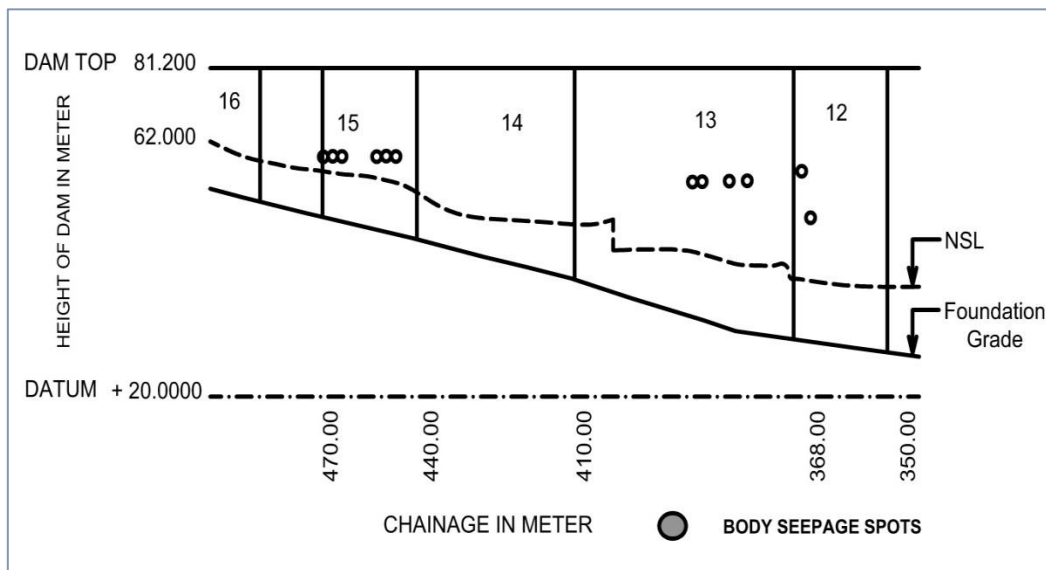

Figure 7 – Location of body seepage in Block No. 12 to 16 on downstream face

Pattern of holes adopted for grouting in a typical Block no.7 is shown in Figure 8 below. Figures 9 and 10 are photographs showing dam body seepage behind head sluice and in spillway portion respectively.

Figures 11 and 12 show excessive seepage from gallery drainage holes. Figures 13 and 14 show choked porous concrete drains.

The damages/deteriorated wearing coat on spillway glacis can be seen in Figure 15.

Figures 16 show the area adjacent to spillway bucket where the downstream apron was recommended and Figure 17 shows the damaged rubber seal of spillway radial gate.

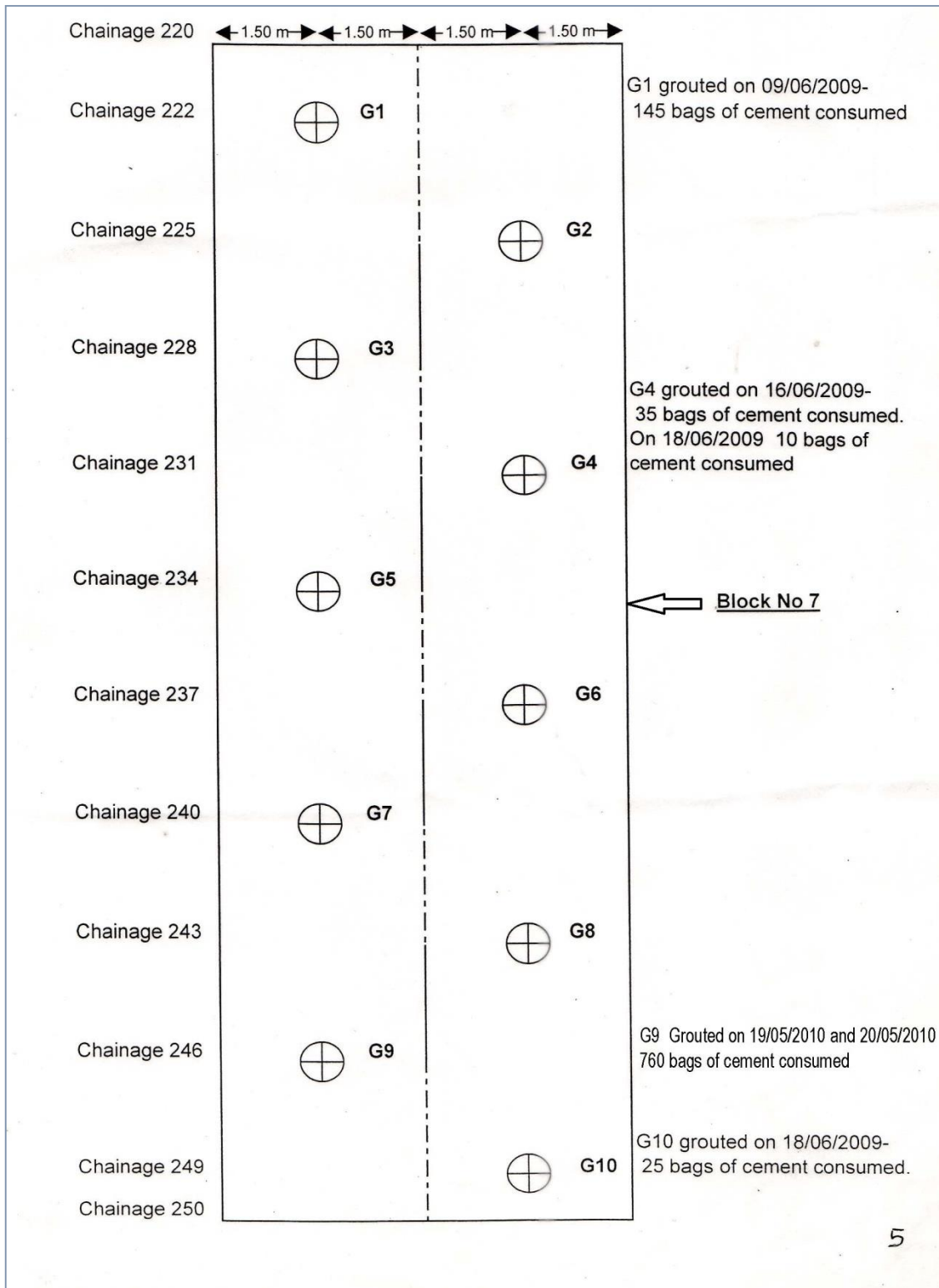

Figure 8 - Position of grout holes in a typical Block No. 7





Figure 9 - Photograph showing dam body seepage behind a NOF block



Figure 10 – Photograph showing dam body seepage at spillway portion





Figure 11 – Photograph showing excess seepage through the gallery drainage holes



Figure 12 – Photograph showing excess seepage through the gallery drainage holes



Figure 13 – Photograph showing choked porous holes



Figure 14 – Photograph showing choked porous holes





Figure 15 – Photograph showing deteriorated glacial on spillway portion



Figure 16 – Photograph showing location of the recommended apron d/s of the bucket



Figure 17 – Photograph showing damaged rubber seal of spillway radial gate

### 1.5 Sonic Tomography

M/s Sol Geo conducted the Sonic Tomography tests for dam during December 2013 using P wave velocity. Tomography was done along 10 no. transverse sections (4 no. in the left NOF blocks, and 3 no. in spillway section and 3 no. in right NOF blocks) and along 2 no. longitudinal sections. The locations of the sections were chosen where the seepage was found excessive.

Figure 18 shows locations of the sections along which tomography was performed.

The sonic survey was carried out utilizing a 16 bit and 2 MHz sampling SOLGEO system that meets the ASTM D4228 specifications for recording systems.

The sonic equipments used for transverse sections consisted of Acquisition Unit – 1 Unit, P.C. - Unit, Piezometric ICP accelerometer – 6 Units, Sparker probe Solgeo – 1 Unit, Sparker Cable Solgeo – 1 Unit, Energy power EG&G234 – 1 Unit, Triggered hammer Solgeo – 1 Unit, Link cable, BNC cable 500 m, Radio – 3.

For longitudinal sections the sonic equipment used consist of Acquisition Unit Geode Geometrics – 1 Unit, Geophones – 24 Units, Seismic cables – 2.



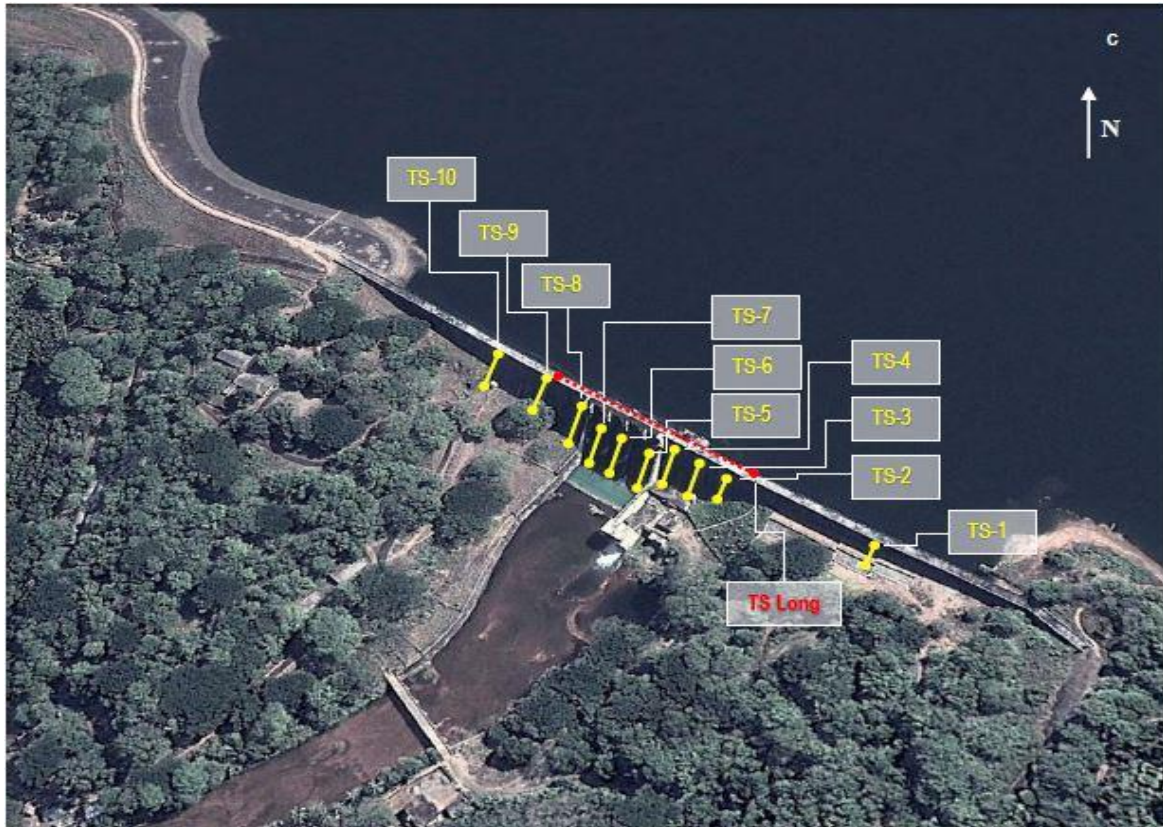

Figure 18 – Photograph showing location of sections on which tomography was performed

Typical transverse and longitudinal sections showing seepage zones are given below in figures 19 to 24.

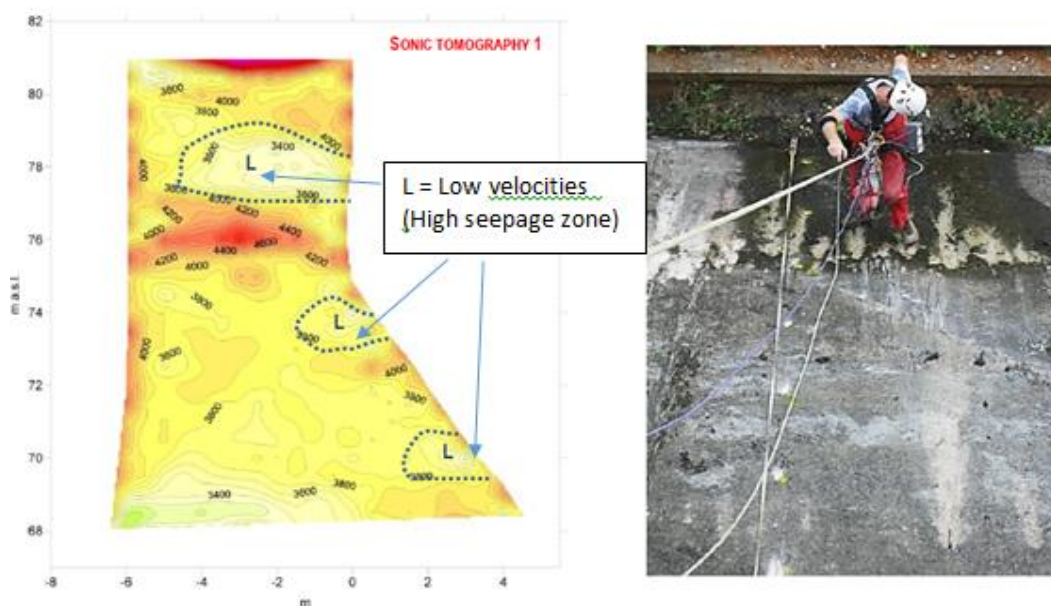

Figure 19 – Sonic tomograms relating to ST-1 and a view of the receiver points on downstream side

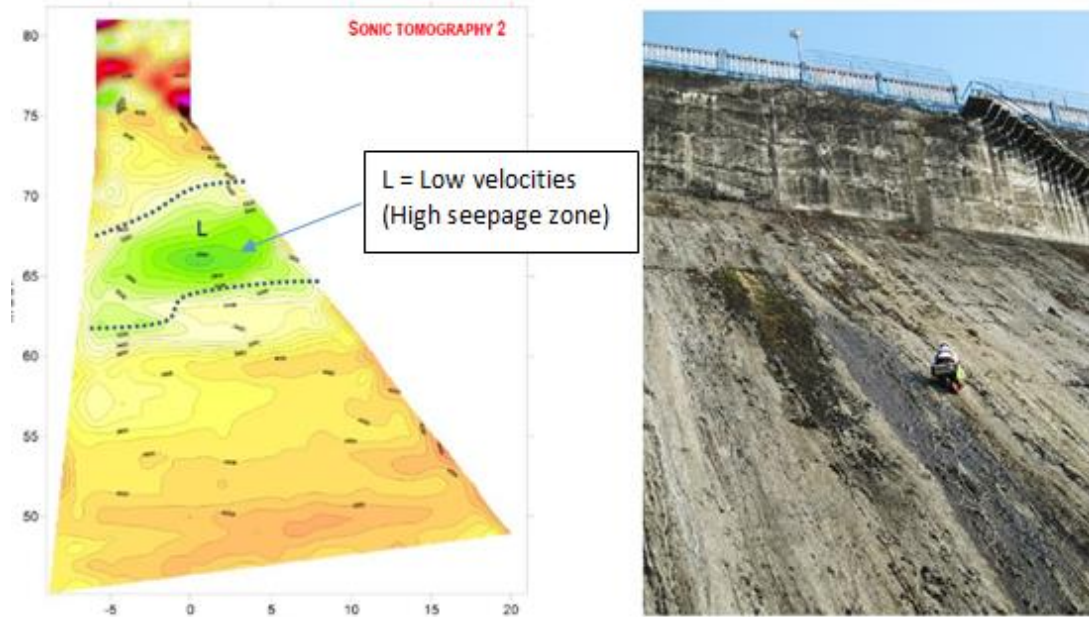

Figure 20 – Sonic tomograms relating to ST-2 and a view of the receiver points on downstream side

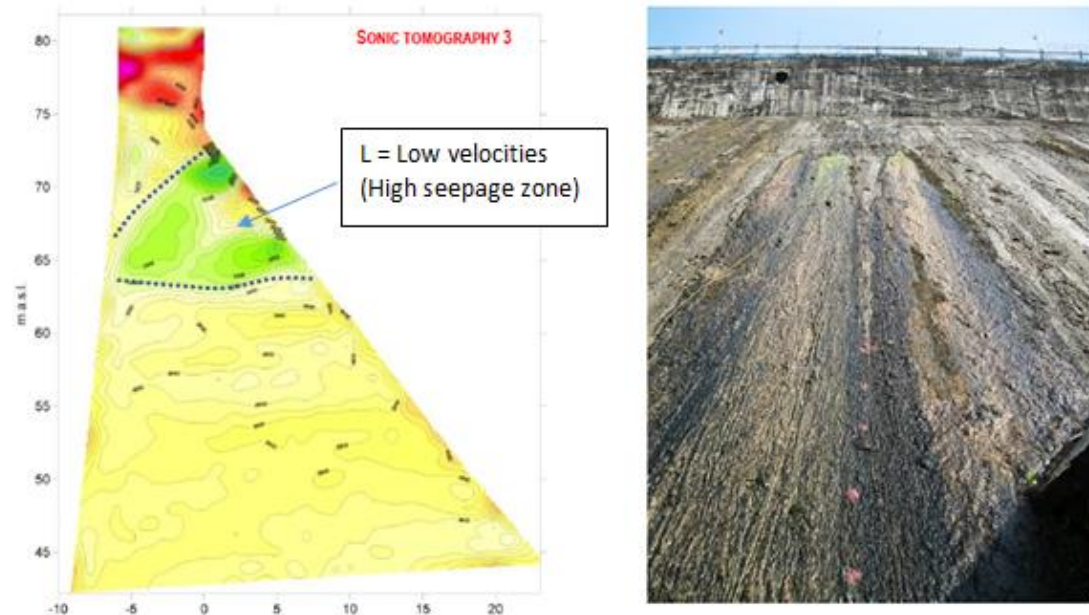

Figure 21 – Sonic tomograms relating to ST-3 and a view of the receiver points on downstream side



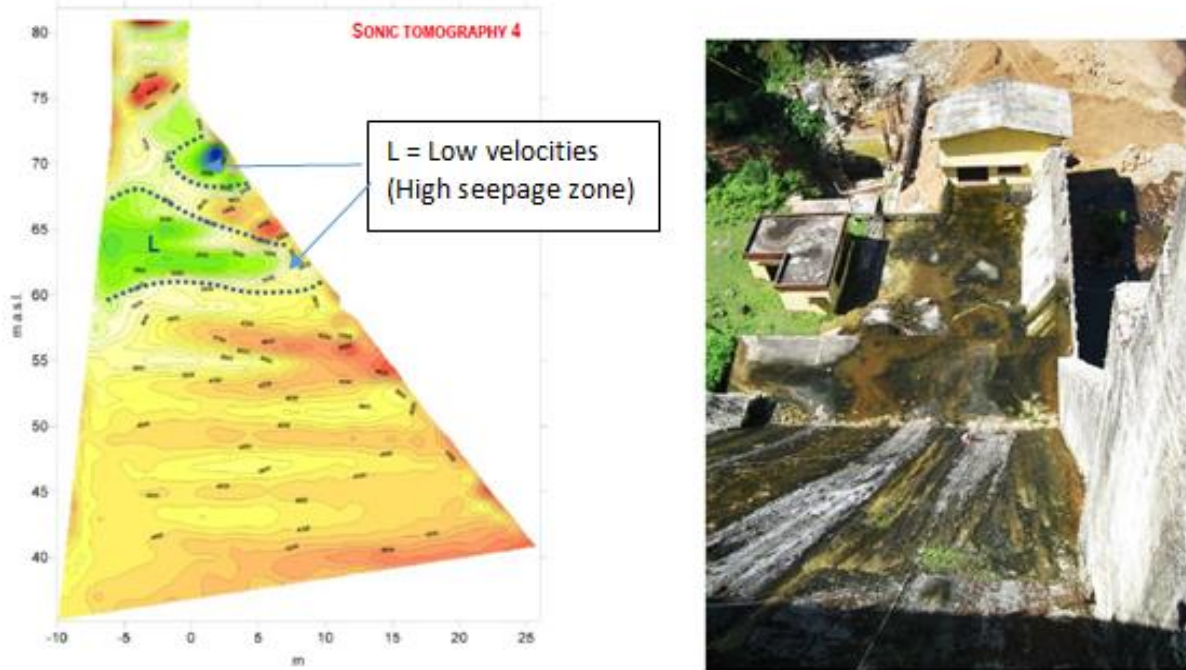

Figure 22 – Sonic tomograms relating to ST-4 and a view of the receiver points on downstream side

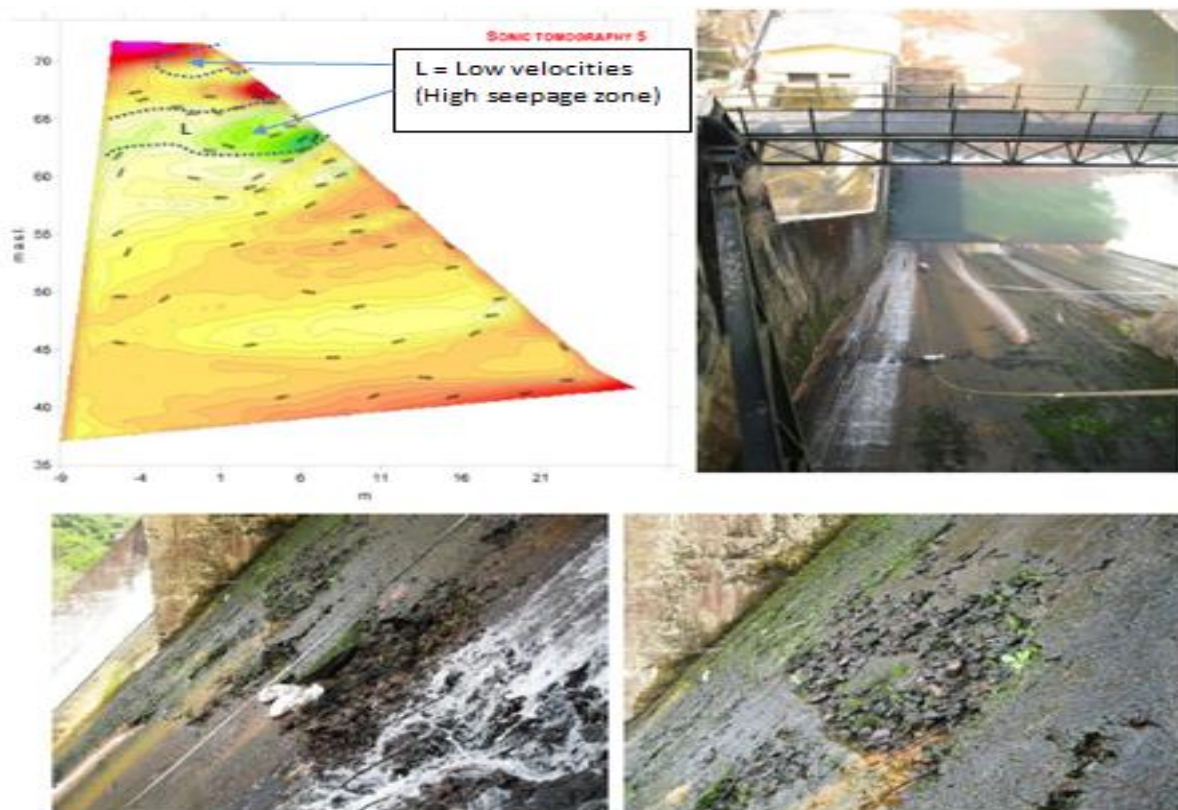

Figure 23 – Sonic tomogram relating to ST-5 and a view of the receiver points on downstream side and some details of damaged areas



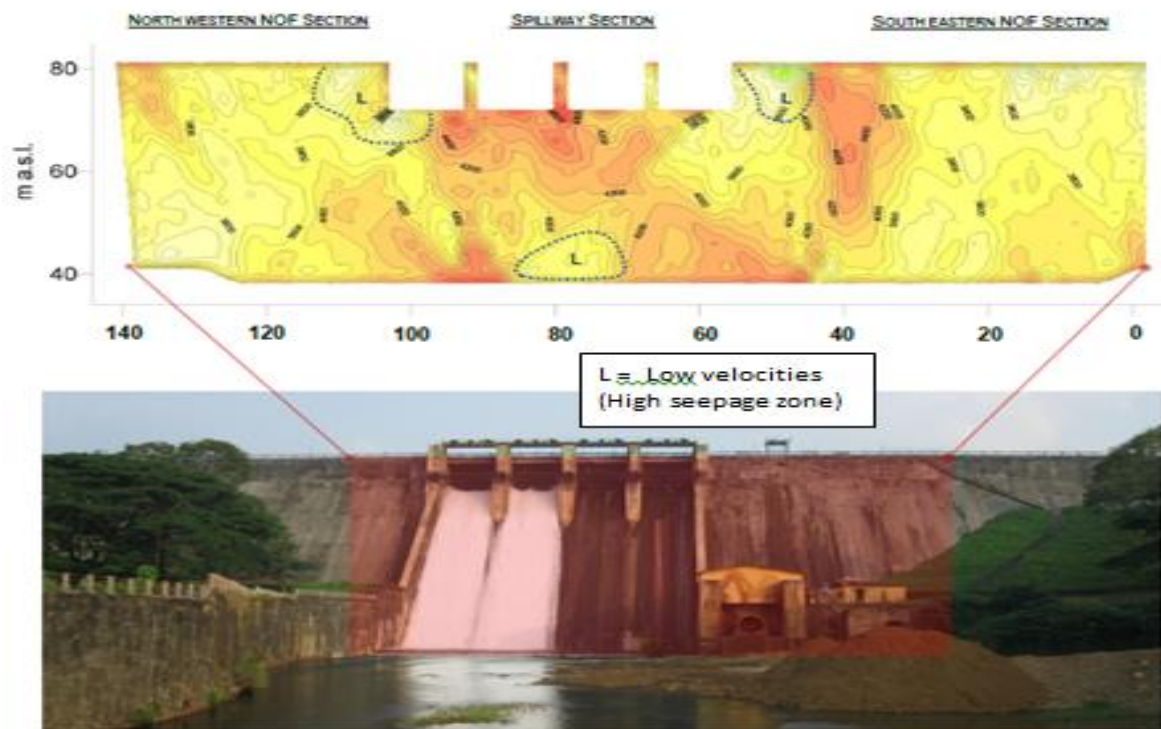

Figure 24 – Sonic tomogram relating to longitudinal section (above) and a panoramic view of the dam from downstream side (below)

### 1.6 Design Flood Review

In terms of Indian Standard IS 11223 – 1985 classification criteria, Chimoni Dam is classified as a “Large Dam” and hence qualifies for PMF (Probable Maximum Flood) as the design flood. The PMF is evaluated to be 1666 cumec against the original design flood of 1680 cumec. As per the original, MWL is 79.70 m and with TBL at 81.20 m, the available free board is 1.50 m (81.20 – 79.70 m). The PMF being less than the original design flood and the free board being 1.50 m, Chimoni Dam fulfils the hydrology requirement and is capable of safely handling the PMF.

### 1.7 Works proposed under DRIP

The works being executed under DRIP are grouting of Masonry Dam on the basis of the report of Tomography tests already conducted, balance upstream face treatment of Masonry dam with PICC (Poly Ironite Ceramic Cementitious) or equivalent, thorough cleaning of the downstream face of masonry dam and re-pointing of the masonry surface, similar treatment in the Emergency Shutter well of sluice in Block No.8, Cleaning/Reaming of porous concrete body drains from dam top to inspection gallery in Block No.2 to 16, Rectification of the earth dam profile and construction of parapet wall, Construction of toe drain at the downstream toe of masonry dam, Providing electrification arrangements to drainage gallery and dam premises, Repairs of operation platform, spillway shutters, Emergency shutter & sluice valve, Demarcating boundaries and providing chain link fencing, Upgradation of all-weather access road and Construction of camp office cum watchman cabin.

These works are presently under progress.

This page has been left blank intentionally.

## 2. MANERI DAM, UTTARAKHAND

### 2.1 Project in brief

Maneri Bhali Stage-I (90 MW) Hydroelectric scheme was planned to harnesses the energy of waters flowing down river Bhagirathi between Maneri and Uttarkashi. The powerhouse of this project is generating approx. 455 MU energy annually (Average generation from 2004-05 to 2014-15) since its commissioning in October 1984.

This scheme comprises of: -

- a) A 39 m high and 127 m long Concrete Gravity Dam across river Bhagirathi near Maneri which houses the spillway. The spillway is designed to pass 5000 cumec. It consists of four numbers radial gates of size 13 m width & 14.55 m height each, separated by 4m thick piers. A slotted roller bucket is provided for energy dissipation.
- b) Intake structure comprises of three bays 9.00 m. wide each with an all-weather channel on the left flank. A sedimentation tank with total 08 hoppers of 15.00m width, 15.70 m length and 5.75 m depth in 2 rows (i.e. 4 in each row) is provided to remove silt particles which are passed back to the river downstream of the dam through silt flushing tunnel.
- c) An 8.631 km long and 4.75 m diameter circular concrete lined power tunnel (i.e. Head Race Tunnel).
- d) A 69-m high and 11 m diameter underground surge shaft of restricted orifice type along with 316 m long and 6m diameter upper expansion chamber, 89.5 m long and 6m diameter lower expansion chamber.
- e) About 456 m long steel lined penstock of 3.8 m diameter with three branches of 2.5 m diameter just upstream of the powerhouse.
- f) A surface power station near Uttarkashi, housing three Francis turbines of 30 MW capacity each, i.e. total installed capacity of 90 MW. The firm power is 38.23 MW. The design discharge of the power station is 71.4 m<sup>3</sup>/s. The difference in elevation between the barrage and the power station affords a design head of 147.5 metre and a gross head of 180 meters.
- g) Open tailrace channel about 120 m long joins river Bhagirathi at Uttarkashi



Downstream view of Maneri Dam

## 2.2 Extent of damages

Severe floods in the rivers of Uttarakhand in August 2012 and June 2013 badly damaged some hydro-electric power projects mainly in Bhagirathi and Alaknanda river valleys. Spillway of Maneri Bhali Stage –I dam was damaged severely by rolling boulders which resulted in heavy leakages downstream. To arrest leakages, temporary arrangements such as caulking of gates were undertaken. After the monsoon of 2014, comprehensive rehabilitation/repair of Maneri Dam was planned after studying the damages of similar nature and treatment/ measures undertaken at other hydroelectric projects. The spillway bay no. 1 & 2 on the right bank were badly damaged. The repair works of these spillways were planned on priority basis in two phases: -

- a) Repair work from the sill beam of stop log gates to 2.00 m downstream of sill beam of radial gates was planned by taking minimum shutdown of Power House.
- b) Repair work in entire spillway glacis from 2.00 m downstream of sill beam of the radial gate was planned in running powerhouse condition.

Repair of entire bucket and realignment of the downstream training wall were planned subsequently.

The damages observed in Spillway bays no. 1 & 2 on the right bank (Photograph 1) were mainly as under: -

- a) The sill beam of stop log gate and radial gate was washed out in approximately 6.00 m and 8.00 m length (out of a total length of 13 m) respectively. The flange of the remaining sill beams was completely damaged.
- b) As both the sill beams were washed out in some length, therefore a cavity of about 6 - 7 m in length (along with the piers) having a depth up to 2.00 m was created in between the radial gate and stop log gate. The flood also damaged the spillway glacis d/s of radial gate sill beam throughout its length & up to the slotted roller bucket in about 3.00 m width with a varying depth of maximum 13.00 m.



Photograph 1 shows the damages in Spillway bay no-1

The damages observed in Spillway bays no. 3 & 4 on the left bank were mainly as under: -

- a) The concrete in between stop log gate and the radial gate was eroded by the flood. The maximum depth of the erosion was in the range of 0.25 m to 0.70 m.
- b) The profile of spillway glacis was also damaged from 0.25 m to 0.80 m in depth.

### 2.3 Study of damages

A close examination of the flow conditions in Maneri Bhali Stage-I dam reveals that the following were the major reasons of damages

- a) Maneri dam was silted up to the spillway crest. Because of this, the boulders which come with the floods in monsoon period roll down the spillway and cause damages to the spillway glacis, bucket and downstream training walls of Maneri dam.
- b) In the upstream side, there is a turn in the river and shortest radius of the turn is towards the bay no.1 on the right bank. Because of this, rolling boulders in monsoon season pass more through bay no. 1 in comparison to other spillway bays resulting in more damages in the bay.
- c) The width of the river downstream of the slotted roller bucket is converging towards downstream. Because of this there are return flows and the ground roller brings eroded materials in to the bucket.

### 2.4 Rehabilitation/Repair works executed in bays No. 1 & 2

#### 2.4.1 Repair works from the sill beam of stop log gates to 2.00 m downstream of sill beam of radial gates

For carrying out these works a detailed planning of execution of repair works of three spillway bays from sill beam of stop log gate to 2m d/s of sill beam of the radial gate with-in minimum possible time was done. A period of 36 days starting from 02/12/2014 to 07/01/2015 was finalized for closing the Power House of Maneri Bhali-I HEP.

Following activities were performed in sequential order to complete the works:

- a) Creation of bund in front of spillway bay 1, 2 & 3 to divert water through spillway no. 4.
- b) Dismantling damaged mild steel sheets previously placed over spillway concrete profile.
- c) Damaged & remaining sill beams of stop log gate and radial gate were removed.
- d) Dismantling of concrete so as to get a minimum thickness of 250 mm of new concrete and a cover of 200 mm over the reinforcement.
- e) Drilling hole of 600 mm depth and 32 mm diameter in a staggered manner in parent concrete for fixing anchors.
- f) Fixing 25 mm diameter Fe 500 TMT bars in drill hole with grouting material for anchorage of reinforcement as well as dowel bars for fixing of MS plates.
- g) The reinforcement was laid with 20 mm diameter bars @ 150 c/c keeping the top cover of 200 mm. Where the cavity was more than 80 cm deep, reinforcement was provided in intermediate layers also keeping the top cover & bottom cover of 200 mm.
- h) Applying bonding coat (BASF make) between old and new concrete.
- i) Laying of concrete (ACC make Drycrete of M80 grade) in the cavity between sill beam of stop log gate and radial gate.



- j) Fixing sill beams i.e. ISMB 300 (300 X 140) conforming to IS: 2062 (E250) with 20mm SS plate for Stop Log gates and Radial gates.
- k) Laying concrete (ACC make Drycrete of M80 grade) up to the final level as per the profile.
- l) Fixing MS sheet (20mm thick with a yield strength of 450 MPa) over the prepared concrete surface.
- m) Grouting between steel plate and concrete through holes cut in the steel plate.

To complete the repair works of spillway bays no. 01 & 02 within stipulated period, all the pre-requisites such as manpower, material etc. were arranged before the start of work. The works were taken up in 3 shifts continuously and completed within 36 days and the Power House was restarted thereafter.

#### 2.4.2 Repair Works in Spillway Glacis

Repair works in spillway glacis was carried out from 2m d/s of radial gates during power house running condition. All activities were same as stated above only instead of M80 Dry Crete, M60 grade concrete was used.

Based on IS: 10262-2009 and IS: 456-2000 a mix design for M60 concrete was worked out which is as under:

a) Cement	=	450 kg/m <sup>3</sup>	b) Water	=	157 kg/m <sup>3</sup>
c) Silica fume	=	25 kg/m <sup>3</sup>	d) Fine Aggregate	=	598 kg/m <sup>3</sup>
e) Coarse Aggregate	=	1269 kg/m <sup>3</sup>	f) Chemical Admixture	=	7.125 kg/m <sup>3</sup>

The 28-day target strength of trial mix proportions for M60 grade of concrete was achieved as 68.9 N/mm<sup>2</sup>.

Some photographs showing the works carried out are given below.

Photograph 2 shows the Temporary Bund for channelization of stream water which was constructed for the repairs in Spillway bays 1 and 2.

Photograph 3 shows the laying of concrete in spillway bay no-2.

Photograph 4 shows the laying and grouting of MS Plate in Spillway bay no 2.



Photograph 2 (Temporary Bund for channelization of stream water)



Photograph 3 (Laying concrete in spillway bay no 2)



Photograph 4 (Laying and Grouting of MS Plate in Spillway bay no 2)



## 2.5 Rehabilitation/repair works proposed in spillway bay no 3 & 4 & entire bucket and training walls

During execution of repair works of spillway bays 1 & 2, the entire slotted type roller bucket and training walls were also examined and it was found that the slots of roller buckets are completely damaged. Both side training wall were also found damaged very badly (Photograph 5). Deep cavities were also found ranging between 1.00 m to 4.00 m in front of all the four bays of roller bucket (Photograph 6).



Photograph 5 (Damaged Training wall)



Photograph 6 (Cavity in Slotted Roller Bucket)

### 2.5.1 Proposed repair of spillway glacis in bays no 3 & 4

It has been proposed under the Dam Rehabilitation and Improvement Project (DRIP) to

repair spillway glacis of one of the remaining bays 3 and 4 with M90 grade concrete and the other with M90 grade concrete along with steel fibers. The remaining procedure of repairing will be same as executed in spillway bays no. 1 and 2. Mix design for M90 grade concrete will be provided by National Council for Cement and Building Materials (NCCBM), Ballabgarh.

#### 2.5.2 Proposed repair of slotted roller bucket

It has been proposed to repair the energy dissipation arrangements with M90 grade concrete along with steel fibres after carrying out hydraulic model studies. The final energy dissipation arrangement to be adopted viz. Slotted roller bucket with the existing design or its modification into a stilling basin would be decided based on model studies.

### 2.6 Conclusions

Repair works of spillway glacis in bays no. 1 and 2 were carried out by using M60 grade concrete and fixing MS steel plate over prepared profile followed by cement grouting. The MS plates provided were found intact after passage of the monsoon flows of the years 2015 & 2016.

The repair works of the glacis of spillway bays no 3 & 4 as proposed above and the performance of M90 grade concrete with and without steel fibers will be examined after the monsoon subsequent to completion of works. On monitoring of the spillway performance after these three diverse types of repair works are undertaken and completed conclusions can be drawn as to which method is the most suitable for repairing of spillway glacis and energy dissipation arrangements for the severe conditions prevalent in this project.

The repair works of training wall are also being undertaken and the waterway on the downstream is planned to be increased to that in the spillway, to improve the downstream flow conditions and reduce the damage potential.

This page has been left blank intentionally.

### 3. KONAR DAM, JHARKHAND

#### 3.1 Introduction

Konar dam of Damodar Valley Corporation (DVC) is located on Konar River in Hazaribagh district of Jharkhand about 30 km above the confluence of Konar River with Damodar River. It was included in the first phase programme of unified development of the Damodar Valley. It is an earth-cum-concrete dam about 3682.00 m long, which includes a 277.00 m long Concrete gravity dam flanked by earthen dams on either side. The maximum height of the Concrete dam is 190' (58 m). The Concrete gravity dam has certain unique features viz. it has hollow spaces in between the block joints and has eccentrically located piers (near the transverse contraction joints) instead of centrally located piers in the spillway blocks. There are three galleries in the Concrete dam i.e. Inspection gallery at El. 1340' (408.432 m), Access gallery at El.1285' (391.668 m), and a foundation gallery at lower elevations. The construction of the dam was taken up in October 1950 and was completed in October 1955. Cracks were observed in the top inspection gallery in 1962-63, about 7 years after the completion of the dam. Concurrently, cracks were also observed – though comparatively less prominent – in the other two galleries i.e. in the Access gallery and in the foundation gallery. Cracks appeared on both downstream and upstream faces of the galleries and were found in all the blocks. Cracks inside the top inspection gallery were wider than the cracks in other two galleries, which further expanded with time. Surface cracks were also noticed in the downstream slope of non-overflow sections of the dam. Several studies were carried out in past, to understand the cause, nature, and behavior of the cracks and the advice of Expert Committee's sought. These cracks in the top inspection gallery at El.1340' were grouted with epoxy in 1971 but they re-appeared in 1973. Several tell-tales were installed which suggested the widening and shrinkage of cracks over the years; but since 2009-10, the cracks appeared to have stabilized. A downstream pictorial view is given below:

The Konar dam is now being taken up for rehabilitation under the ongoing Dam Rehabilitation & Improvement Project (DRIP) The numerical modelling of the Konar dam for investigation of its cracks has been carried out for guiding the rehabilitation process.



Figures 1, 2 and 3 show the Plan of Konar Concrete dam, downstream view and typical Non-Overflow and Overflow sections of the Concrete dam.



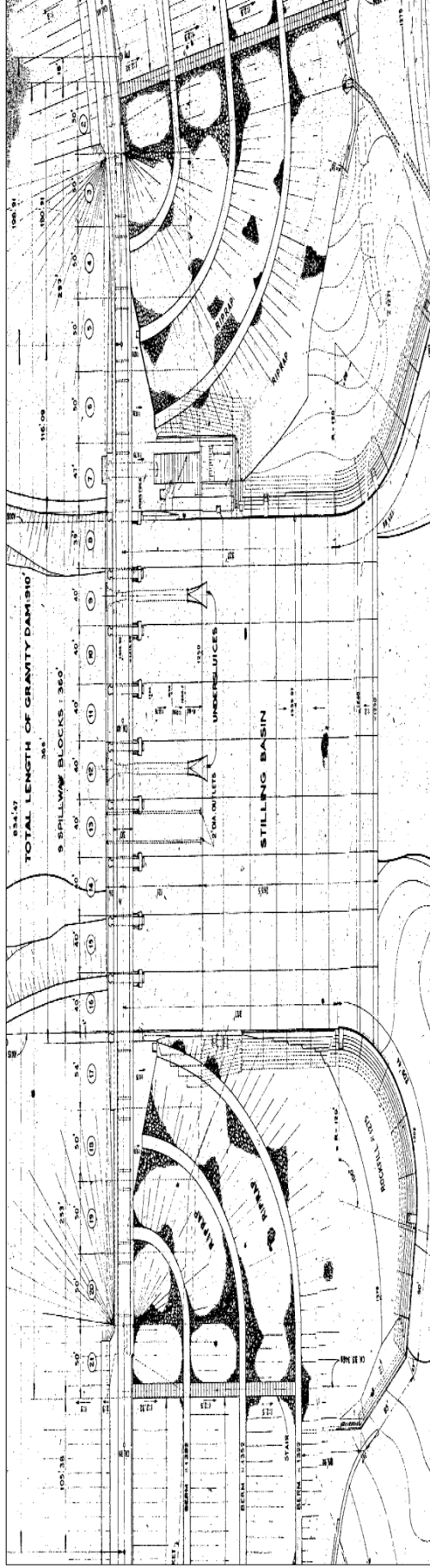
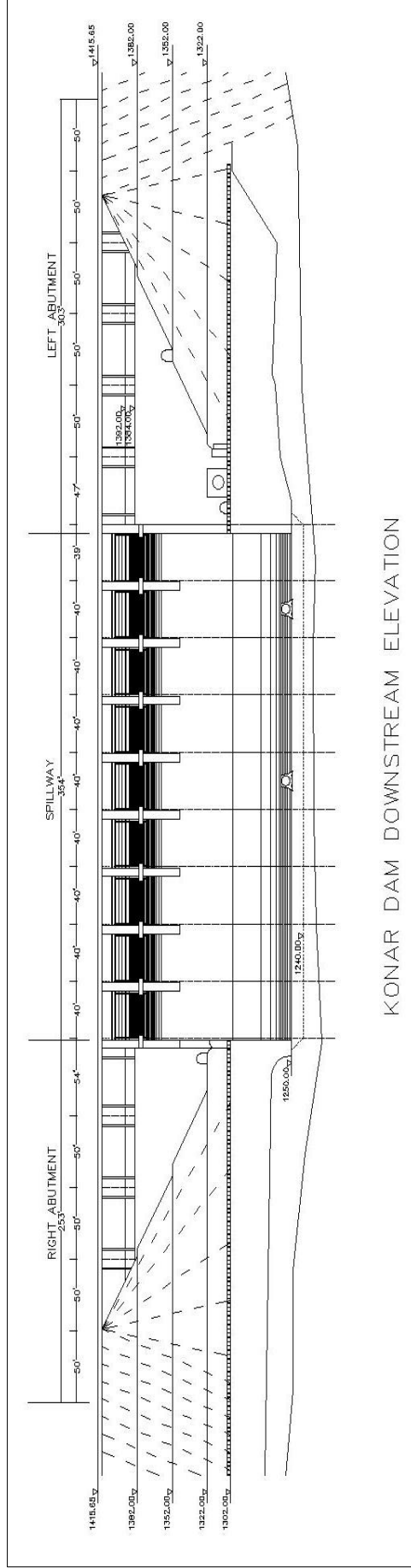

Fig. 1: Plan of Konar Concrete Dam



KONAR DAM DOWNSTREAM ELEVATION

Fig. 2. Downstream view of Konar Concrete Dam

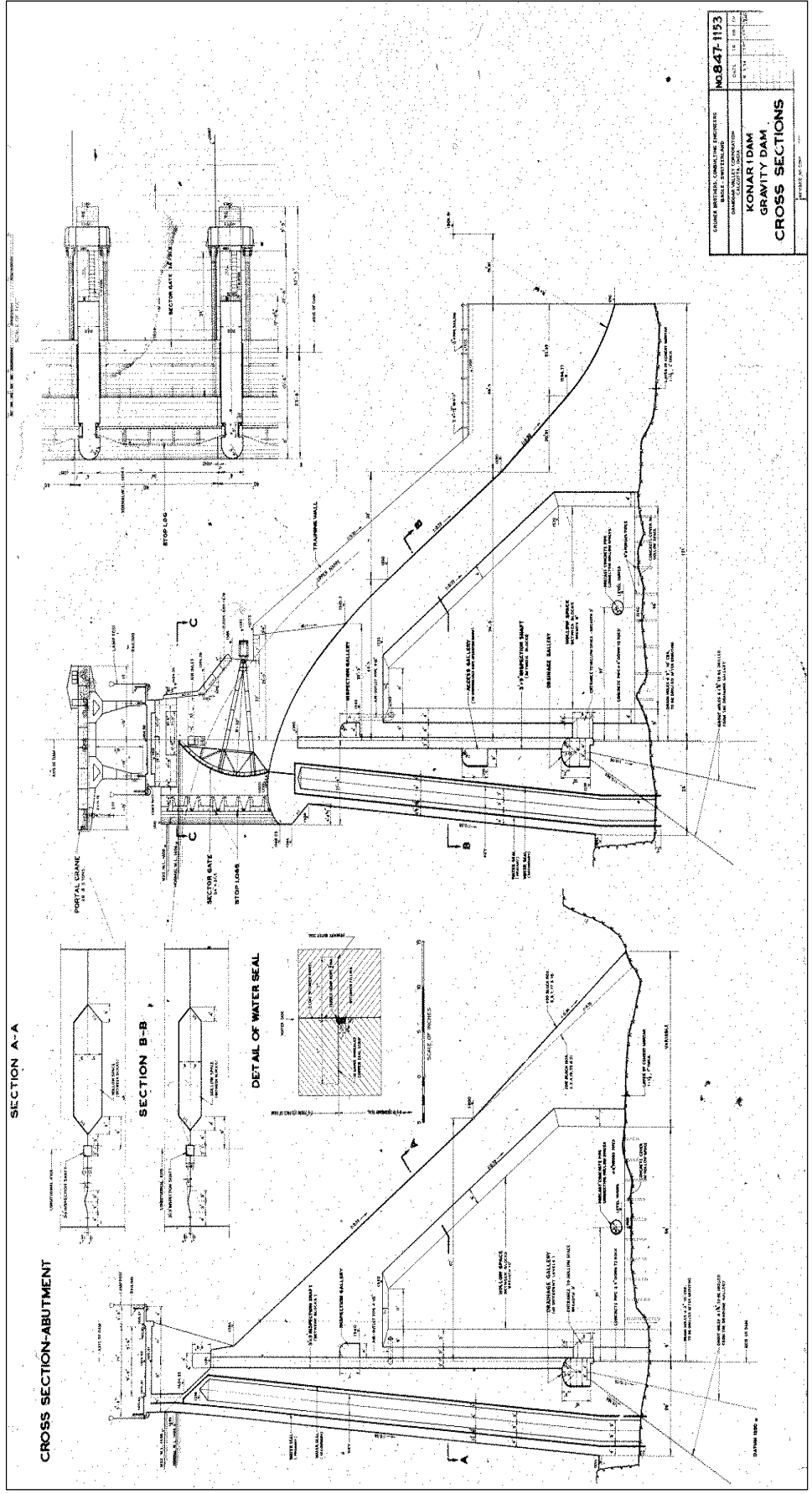

Fig. 3: Typical Non-overflow and Overflow Sections of Konar Dam



## 3.2 Salient features of the dam

Salient Features of Konar Dam		
General	Project Completion date	15.10.1955
	River	Konar
	District	Hazaribagh
	State	Jharkhand
	Latitude	23° 56' N
	Longitude	85° 46' E
Hydrological	Catchment Area (km <sup>2</sup> )	997
	Avg. Annual Precipitation (cm)	132
	Avg. Annual Runoff (MCM)	555
Structural	Type	Composite-Earth & Concrete
	Maximum Height above foundation	190' (57.6 m)
	Overall Length	12080' (3682.03 m)
	Length of concrete dam	910'(279.14m)
	Type of Spillway	Ogee
	Spillway Design Discharge (cumec)	6796
	Spillway crest level	1372.50'(421.01m)
	Crest gate type	Tainter
	Number of Crest Gates	9
	Crest Gate Size	34' x 31'6" (10.36 m x 9.91 m)
	Under sluice – type of gate	Vertical lift
	Number of Under sluices	2
	Under sluice Size	7' 6" (2.29 m) diameter
	Maximum discharge capacity per Under sluice (cumec)	95
Reservoir	Dead Storage Level above MSL	1347' (410.57 m)
	Dead Storage (MCM)	35
	Conservation Level above MSL	1397' (425.81 m)
	Conservation Storage (MCM)	175
	Max. Utilizable Flood Management Level above MSL (Top of Gates level)	1404' (427.94 m)
	Flood Management Storage(MCM)	38
Power	Installed Capacity	Nil
	Type of Turbine	-
	Maximum Head (m)	-

The photographs 1 and 2 show the upstream and downstream views of Konar Concrete dam. The photograph 3 and 4 shows the entrance to hollow spaces of the dam & cracks in the top Inspection gallery, photograph 5 shows the cracks in Access/Operating gallery and photograph 6 shows the cracks in Foundation/Drainage gallery.

The photographs 7 and 8 show the Cracks in downstream face and upstream face of Non-overflow section respectively.



Photograph 1 - Upstream view of Konar Dam



Photograph 2 - Downstream view of Konar Dam



Photograph 3 - Entrance to hollow Spaces of the dam & Cracks in the Inspection gallery



Photograph 4 - Cracks in the Walls of Inspection Gallery

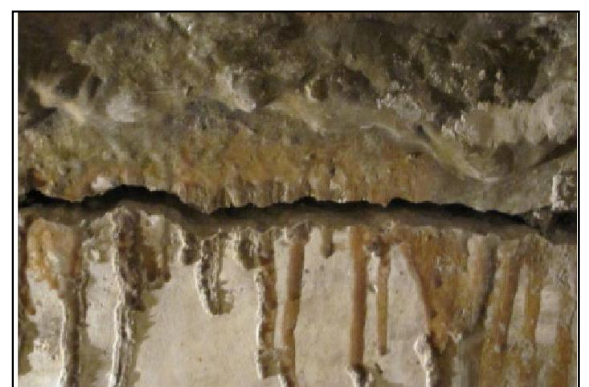





Photograph 5 - Cracks in Access/Operating gallery



Photograph 6 - Cracks in Foundation/Drainage gallery



Photograph 7 - Cracks in downstream of Non-overflow section



Photograph 8 - Cracks in Upstream of Non-overflow section

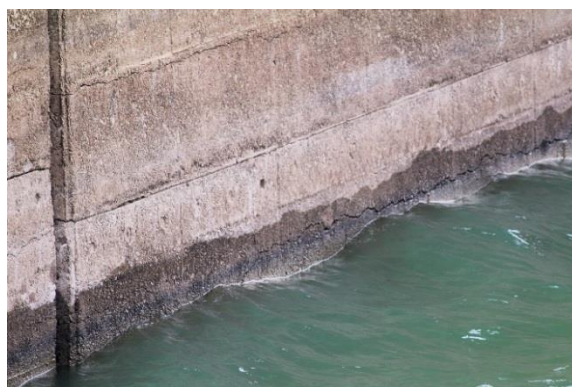

### 3.3 Numerical model

Earlier studies employing numerical modelling (Pant, 1984) had indicated that the surface temperature effects is the major cause of cracking in Konar dam. The studies had ruled out the effect of construction sequence (in the first stage the upstream side of the dam - Stage A was constructed and used for partial storage; the downstream part - Stage B was added later and dam raised to full height (Figure 4)) and the effects of heat of hydration and subsequent cooling on the development of cracks in the dam. In the said study report it was also indicated that “although the present investigation is restricted to a two-dimensional analysis, to interpret the complete behavior of the dam, a three-dimensional analysis is necessary”.

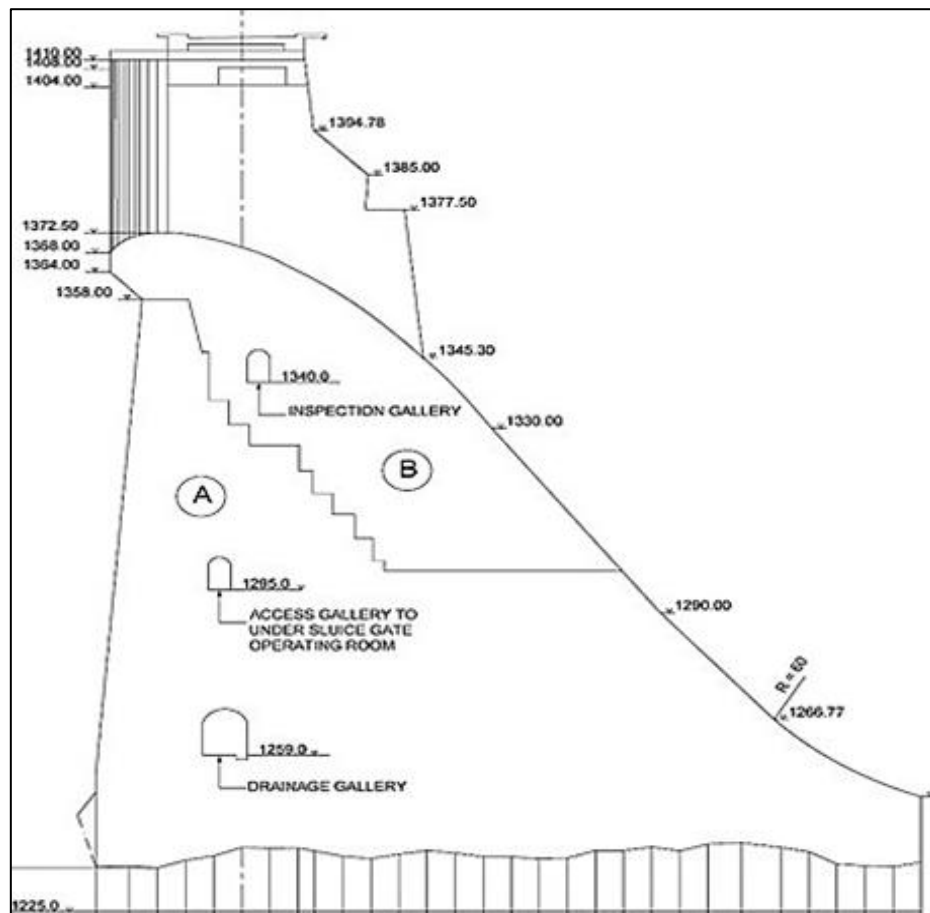

Figure 4 - Stages of Dam Construction

Hence, a detailed three-dimensional (3D) and two-dimensional (2D) finite element coupled thermomechanical analysis was attempted in DRIP.

The three-dimensional numerical model for Konar concrete gravity dam incorporating Overflow (OF) and Non-Overflow (NOF) sections and features of all the three galleries, cavities at the contraction joint location, gates, foundation block, and eccentric piers in overflow section were created in ABAQUS v6.14-4 software environment. Subroutines were used to apply different transient loadings.

The dam-foundation compound model was taken as linear-elastic for materials, but nonlinear in terms of geometry and contacts. The dam-foundation domain was made a discrete region comprising of second interpolation order of 3D elements. The mesh elements used in dam body included both thermal and displacement degree of freedom. For the foundations,

only the displacement degree of freedom was considered because the thermal study of foundations was not carried out.

### 3.4 Meshing Techniques

The numerical modelling for the study involved multiple dam-foundation models, broadly divided into two categories: (i) completely tied model (i.e. between blocks joints, dam body, and foundation); and (ii) discontinuous model. Both the models used cohesive interaction to account for uplift pressures. The discretized 3D numerical dam-foundation model composed of second interpolation order of 3D elements. The 3D model used linear hexahedral elements of type C3D8T (8-node thermally coupled brick, trilinear displacement, and temperature) and linear wedge elements type C3D6T (6-node thermally coupled triangular prism, linear displacement, and temperature, reduced integration, hourglass control) for the dam body, and quadratic tetrahedral elements of type C3D10 (10-node second order quadratic tetrahedron) for the foundation, as defined in ABAQUS element library. The coupled displacement-temperature type elements in the dam body can handle both mechanical loading (i.e. Gravity load, Hydrostatic load, and Silt load) as well as Temperature load from all sources (i.e. ambient air, initial body temperature, reservoir water temperature, and solar radiation in terms of conduction, convection, and radiation). The mesh was kept fine near the galleries and at points of high-stress concentrations to capture the stresses more accurately. The dam-foundation compound model (Figure 5) had over 3.0 million nodes. Total numbers of elements were of the order of 2.7 million, out of which about 93% were linear hexahedral elements of type C3D8T, about 5.5% were quadratic tetrahedral elements of type C3D10, and remaining were linear wedge elements of type C3D6T.

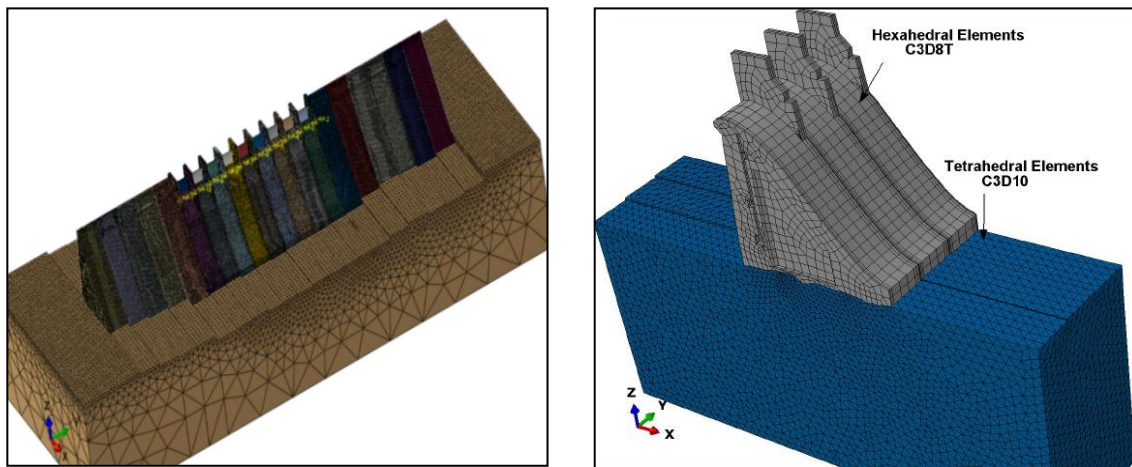

Figure 5 - Meshing in the Dam-Foundation Compound Model

### 3.5 Material Properties Adopted in Model

The testing of dam material was carried out by the Central Soil and Materials Research Station (CSMRS). However, testing was confined to certain parameters pertaining to concrete only. As regards thermal parameters, engineering judgement was exercised as means to define the material properties to serve as inputs. In addition International Committee on Large Dams publication (ICOLD, 2008) was also referred to. Other assumptions made are described in subsequent paragraphs.

### 3.6 Heat Transfer Process and Boundary Conditions

The Fig. 6 below schematically shows the heat transfer process applied in the numerical model.



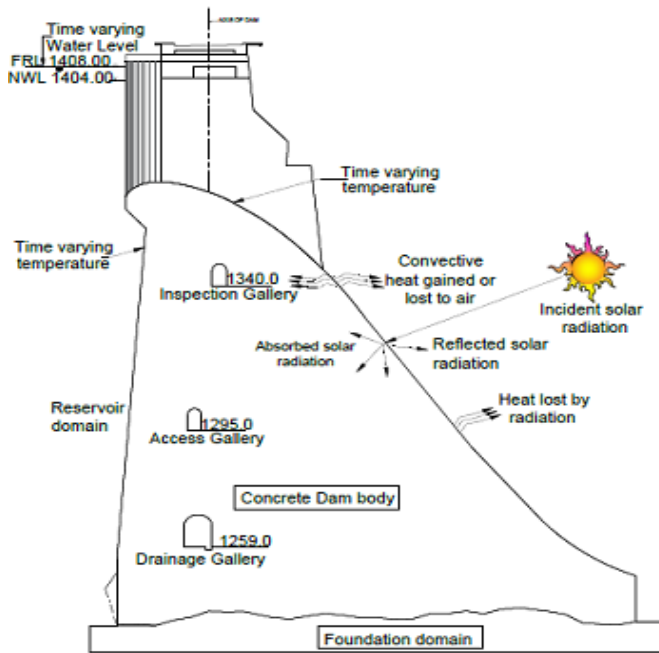
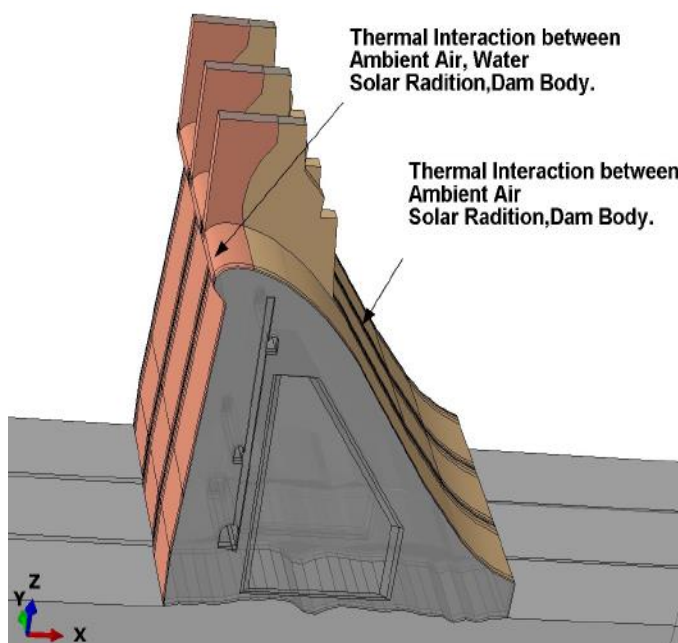

Figure 6: Heat Transfer Process Applied in Model

- Upstream convection to water below water level
- Upstream convection to air above water level
- Upstream radiation to air above water level
- Downstream radiation to air
- Downstream convection to air
- Downstream solar radiation on the dam surface exposed to atmosphere

In the thermal analysis models, two set of values i.e. 20°C and 26.6°C, were taken as the initial dam body temperatures. The said temperatures were applied as a constant predefined field throughout the dam body in ABAQUS. Figure 7 indicates the parameters used in the model to simulate the thermal interaction of dam body with its surroundings.



Upstream ambient air temperature for three years (2013-2015) was considered above the reservoir water levels, where the dam is exposed to atmosphere.

Upstream reservoir water temperature was estimated considering air temperature fluctuations using ZHU Bofang equations.

Solar radiation on D/S face of the dam exposed to the atmosphere was computed using CBRI method.

Downstream ambient air temperature is varied for three years (2013-2015) with solar radiation absorbed by dam surface.

Figure 7: Parameters considered for Thermal Interaction of dam with surroundings



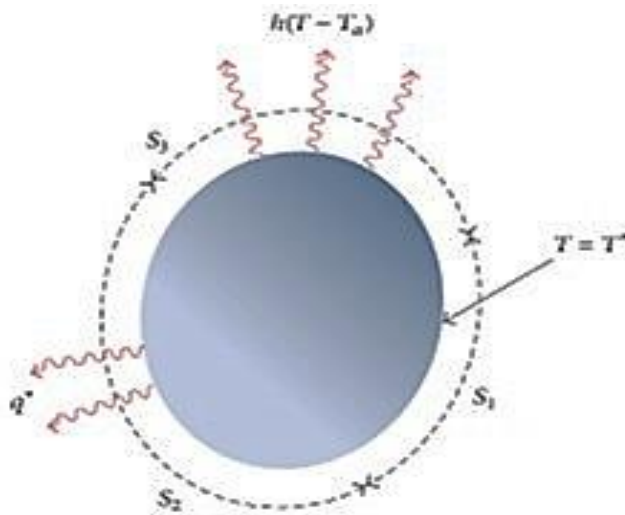

- Prescribed temperature on surface (i.e. constant, or time- dependent)
- Prescribed heat flow on the surface (i.e. absorption of solar radiation)
- Heat flow is linearly dependent on the temperature difference between the surface and the ambient temperature (e.g. convection, heat transfer to the surface)
- Heat flow is non-linearly dependent on temperature difference between surface and ambient temperature (e.g. radiation from the surface of the solid)

Figure 8: Boundary Conditions in Heat Transfer

### 3.6.1 Thermal Conduction, Convection, and Radiation

Heat conduction is a mode of transfer of energy within and between bodies of matter caused by a temperature gradient. Governing equation of thermal conduction in continuous environments can be obtained according to the conservation principle of thermal energy on constant arbitrary volume ( $V$ ), surrounded by closed surface ( $S$ ). For the case of convection, the amount of heat transferred by convection is governed by Newton's cooling law. For the case of radiation, in the present analysis, two forms of radiation were considered: (i) radiation energy absorbed by the surfaces; and (ii) electromagnetic energy released from the surface which is known as thermal radiation. Considering the proper boundary conditions, the equations defining the conduction, convection and radiation of heat for changing surrounding conditions are solved by numerical solution given by Mirzabozorg et al (Mirzabozorg, Hariri-Ardebili, Shirkhan, & Seyed-Kolbadi, 2014).

### 3.6.2 Initial Dam Body Temperature

Considering that Konar dam is about 60 years old with limited instrumentation within the dam body, there is no reliable information about initial temperature distribution within the body. Two separate scenarios with initial temperatures, viz. 20°C and 26.6°C, have been considered. The minimum temperature of 20°C was taken based on the average reservoir temperature which was estimated to be about 18°C; while the initial temperature of 26.6°C was taken as it was the closure temperature of the dam. In ABAQUS, predefined field option was used with initial temperature as constant throughout the region in the initial step. Then thermal transient analysis incorporating thermal loads and constant body temperature was performed for a period of three years considering the imposed boundary conditions and allowing the stresses caused by the temperature regime to stabilize. When the model was analyzed with 26.6°C as initial temperature, the stresses were initially low but progressively increasing; and a reverse trend was observed with an initial temperature of 20°C. Results of the thermal distribution on the nodes at the end of every step are applied to the model again as the new initial conditions for the next step and this loop was repeated for three years when a stable response was reached. The results of the thermal temperature distribution after three years for both the above initial temperature values were found to be almost same.

### 3.6.3 Ambient Air Temperature

The dam site's atmospheric or the ambient temperature ( $T_a$ ) data was obtained from the nearest gauge and discharge station maintained by Central Water Commission (CWC). The data included: (i) Daily mean temperature,  $T_i$ ; (ii) Daily maximum ( $T_{max}$ )<sub>i</sub> and Daily minimum temperatures ( $T_{min}$ )<sub>i</sub>; (iii) Maximum monthly mean temperature,  $T_{max}$ ; (iv) Minimum monthly mean temperature,  $T_{min}$ ; (v) Annual mean temperature,  $T_{mean}$ ; and (vi) Highest and lowest recorded temperatures at the site. The atmospheric temperature cycle was applied for the three years' period. The Figure 9 below shows the variation of air temperature for a typical water year (June 2013 to May 2014):

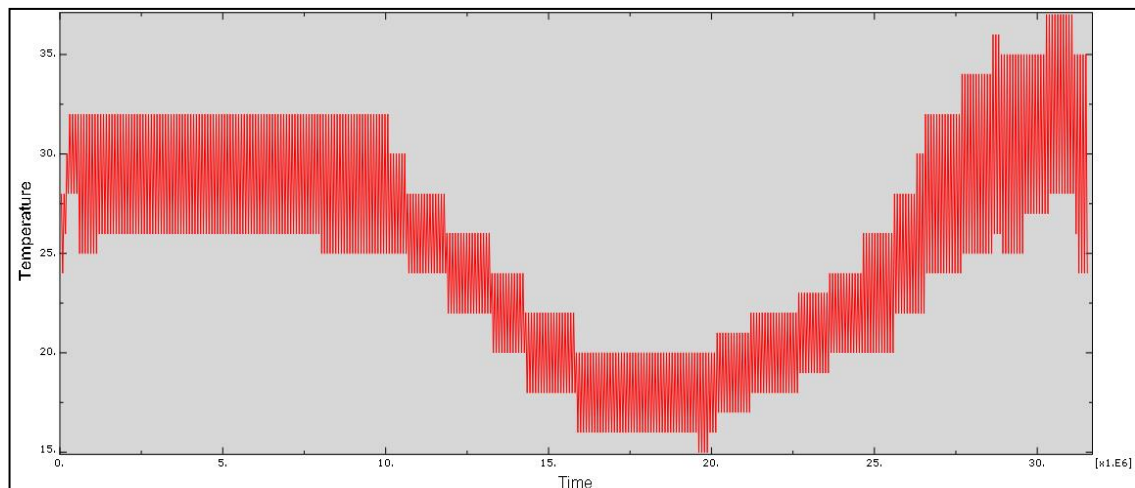

Figure 9: Daily Maximum & Daily Minimum Temperatures for a Typical Water Year

### 3.6.4 Reservoir Temperature

The reservoir water temperature distribution of a large number of reservoirs (as physically measured) is available in Engineering Monograph no 34 of USBR (USBR, 1965). The method proposed by ZHU Bofang (Mirzabozorg, Hariri-Ardebili, Shirkhan, & Seyed-Kolbadi, 2014) is another way for estimation of the reservoir temperature, which was used in the present study. Figure 10 shows the variation in reservoir water level of Konar dam over a period of one year for typical water year of June 2013 to May 2014, and Figure 11 shows the depth-wise distribution of reservoir water temperature (in Celsius) for the same period.

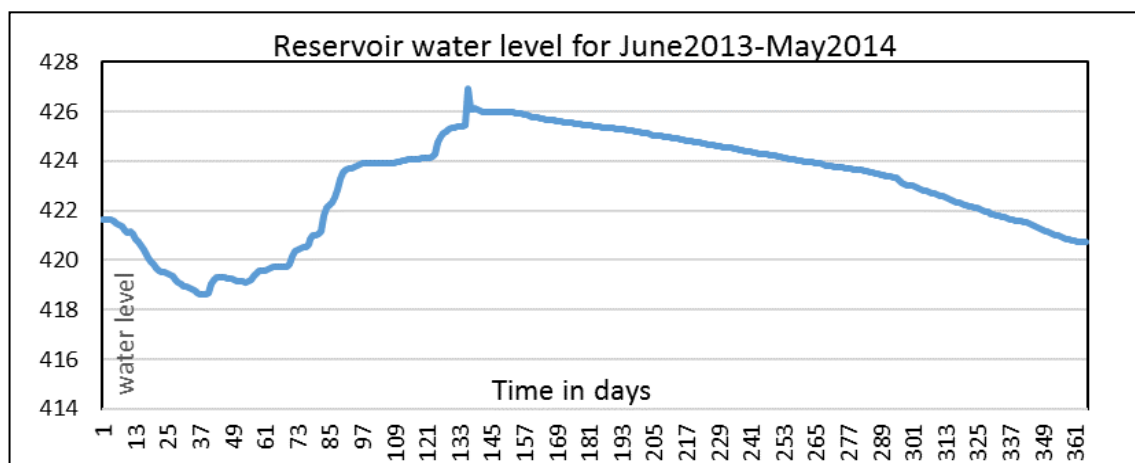

Figure 10: Variation in Reservoir Water Level (Elevation in feet) for a Typical Water Year

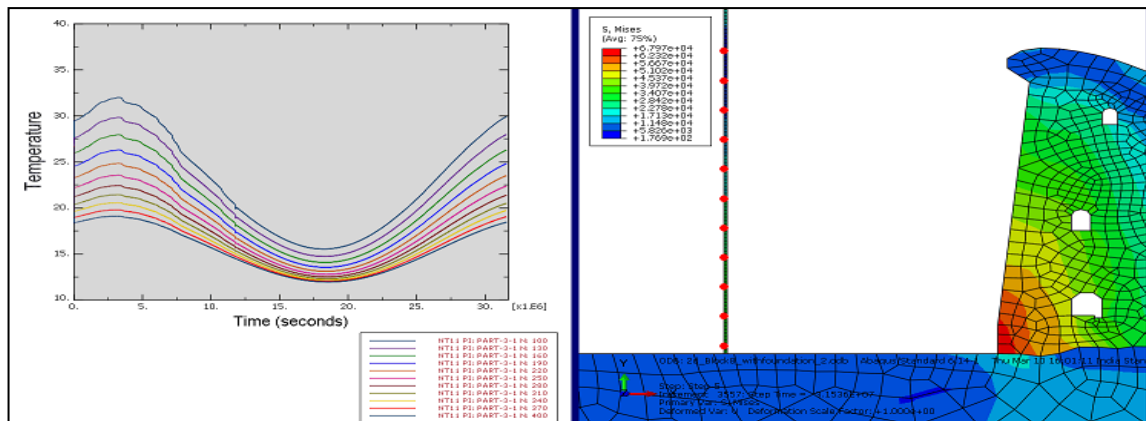

Figure 11: Depth-wise Distribution of Reservoir Temperature ( $^{\circ}\text{C}$ ) for a Typical Year for different nodes marked on the right side diagram

Usually, there is a lag in mean ambient air temperature and mean reservoir water temperature at the deepest level, but the same is not observed in the case of Konar as the depth of reservoir is relatively shallow. The comparative depth-wise variation of ambient air and reservoir water temperature for Konar dam, for the duration of three years, is presented in Figure 12 below:

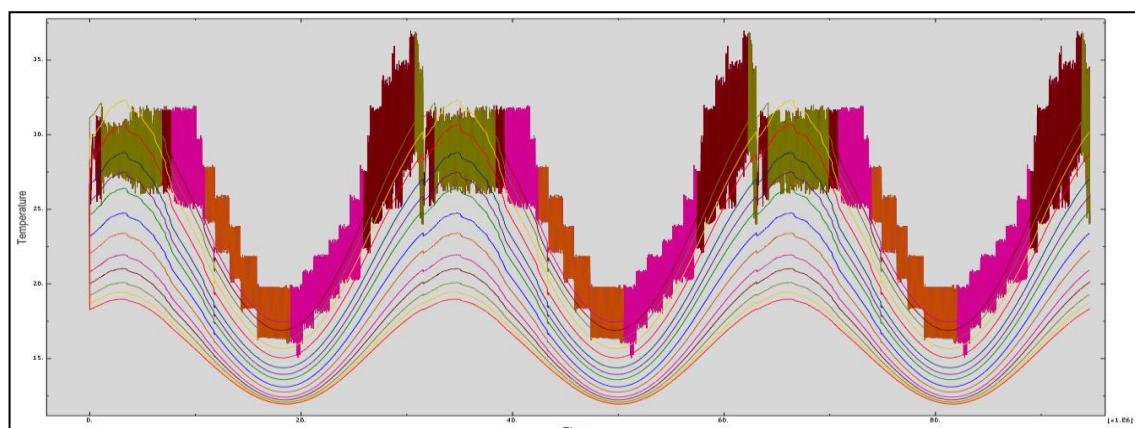

Figure 12: Comparative Variation of Depth-wise Air & Water Temperature for 3 Years

### 3.6.5 Solar Radiation Effect

In Konar dam study, the calculation of direct and diffusive radiation was based on the CBRI method (CBRI, 1994). It was used for computing heat flux. The total solar radiation was calculated using excel sheet and the same was applied in ABAQUS. The subroutine DFLUX was used for applying total heat flux on upstream dam surface based on reservoir water levels. The solar radiation was calculated at two hours interval for the entire three-year period. The amount of the solar radiation received by a dam depends on a series of periodic seasonal changes. This variation is a function of different factors such as the height of dam site above the sea level; surface direction relative to the sun; surface slope relative to the horizon; region cloud cover; surrounding topography of dam site; and time of the year. Solar radiation on the downstream face of the dam may vary depending on the day of the month and time for a day. This variation was analyzed for Konar dam using Sun-Calc application which shows that the downstream face is exposed to solar radiation throughout the year (Figure 13).

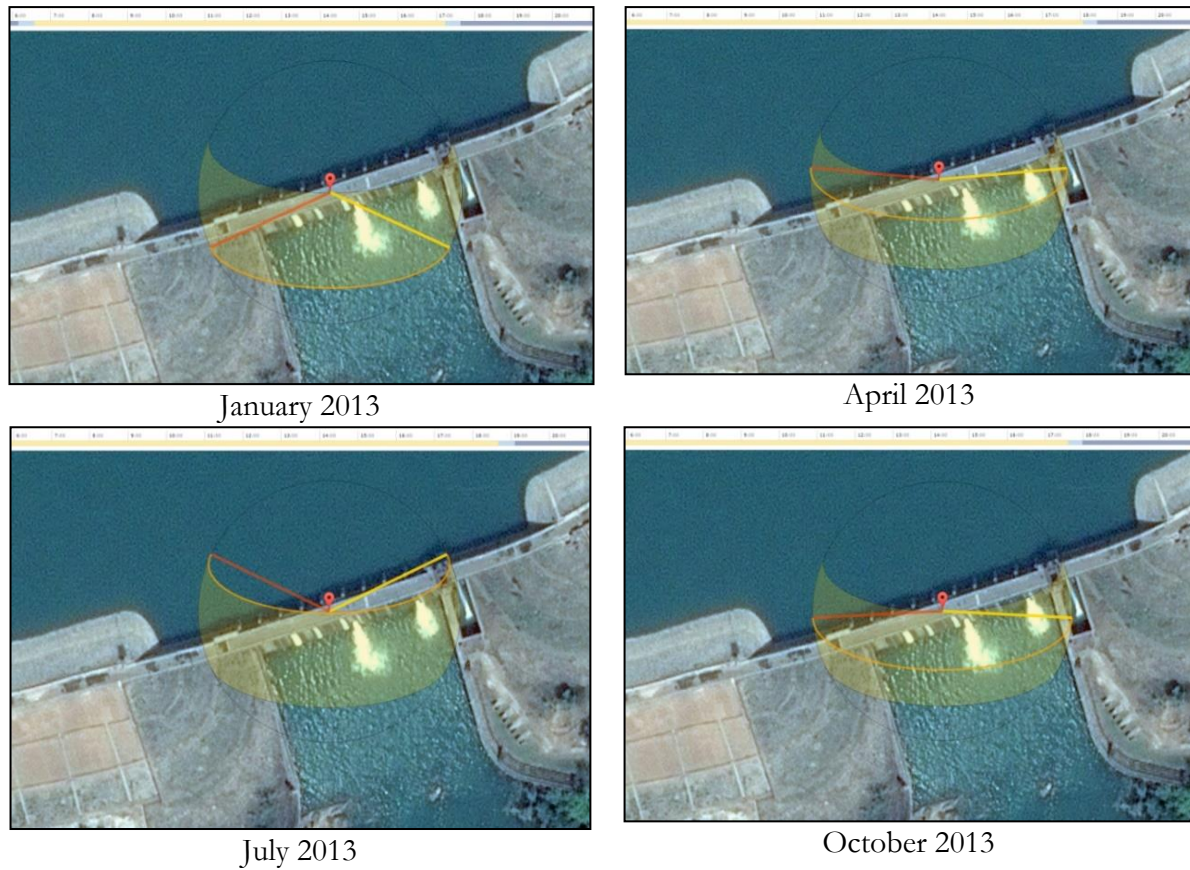

Figure 13: Position of Sun with Reference to Downstream Face of Konar Dam

The maximum ambient temperature as reported by DVC is around 37°C, but the downstream dam surface temperature with solar radiation considered in the earlier study done by WRDTC was 57.2°C (Pant, 1984). To take into consideration the variability of ambient and dam downstream surface temperature, a capped solar radiation scenario – by not allowing the radiation energy to fall below 532 W/m<sup>2</sup> has been considered (Figure 14). The cap in solar radiation resulted in a rise in final temperature of dam body beyond the ambient temperatures by about 3°C. However, the maximum temperature considered in the present study was still much lower than 57.2 °C.

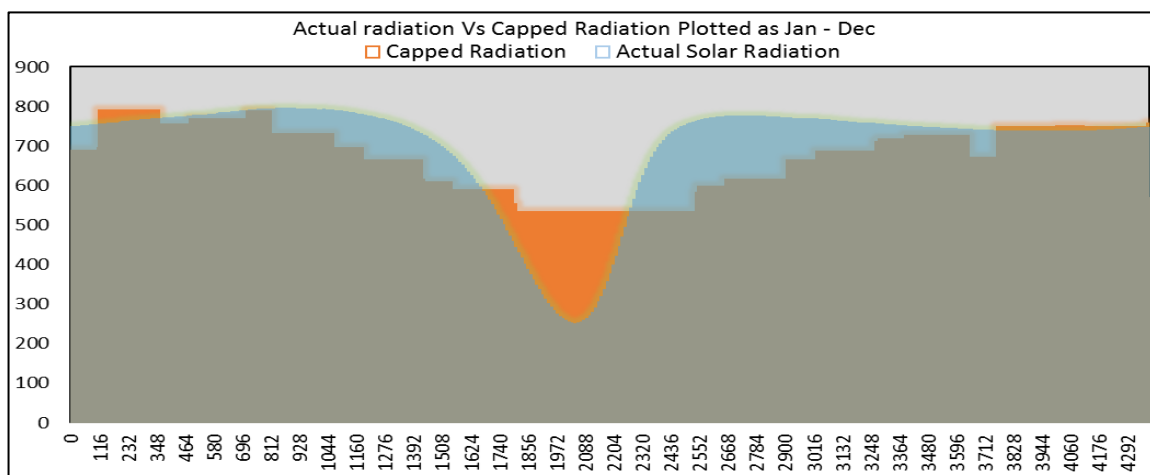

Figure 14: Total Radiation Vs Capped radiation (January-December)



### 3.7 Results of Study

Numbers of models were developed and analyzed for various conditions discussed in earlier paragraphs; this involved considerable computational time and cost. To optimize the resources available, the Primary Model was developed in three-dimensional geometry and the results of analysis were compared with the results of a two-dimensional model (involving same material properties and loading conditions) corresponding to the most critical block – Block No.13. Because the results of the 3D and 2D model were found to be about the same, it was decided to develop all other models in two-dimensional geometry considering the 2D model of Block No 13 as Base Model (BM). The Base Model was analyzed for conditions of no uplift; initial temperature of 26.6°C; normal operating water levels – varied for actual data up to FRL; thermal loading including solar radiation; and loads on account of Gravity and Silt. The materials parameters of concrete considered for Base Model were as under:

- Modulus of Elasticity ( $E_c$ ) of 2.1E5 kg/cm<sup>2</sup>;
- Poisson Ratio ( $\mu$ ) of 0.2; and
- Coefficient of Linear Expansion ( $\alpha$ ) of 1E-5/°C.

Other models were developed for accounting variations in parameters vis-à-vis Base Model as under:

Sensitivity analysis for concrete properties:  $E_c$ ,  $\mu$ , and  $\alpha$  by varying one parameter of the Base Model at a time.

Extreme uplift was considered assuming drains to be inoperative.

Effect of capping the minimum extent of solar radiation and not allowing it to go below a threshold value for the summer period. However, the maximum temperature considered in the study was still much lower than 57.2 °C which was considered in the earlier study.

Filletting (rounding of the corners) the bottom edge of inspection gallery for reducing stress concentrations.

Effect of emptying the reservoir up to minimum drawdown level.

Effect of considering a lower initial temperature i.e. 20°C instead of 26.6°C.

The impact of cracks in gallery on redistribution of stress.

Effect of partially plugging the inspection gallery considering Modulus of Elasticity of Concrete ( $E_c$ ) as: 2.1 E 5 kg/cm<sup>2</sup>; and 3.5 E 5 kg/cm<sup>2</sup>.

Effect of fully plugging the inspection gallery considering Modulus of Elasticity of concrete ( $E_c$ ) as: 2.1 E 5 kg/cm<sup>2</sup>; and 3.5 E 5 kg/cm<sup>2</sup>

Because the study focused on the cracks appearing in the top inspection gallery, the normal stress (S22) in the global Z direction of the model for surface nodes of the gallery (accounting for tensile stresses on the gallery walls) were extracted for comparison. The model variations and their descriptions, along with the maximum value of tensile stresses (Corresponding to S22) computed for the models studied are presented in Table 1. The maximum impact on the tensile stresses was seen to be from the temperature loading.

### 3.8 Conclusions & Recommendations

The present study confirms that the surface temperature effects is the major cause of cracking in Konar Concrete dam.

Table 1: Maximum Tensile Stresses (S22) in Top (Inspection) Gallery

Sl. No	Model Variation	Model Description	Max. Tensile Stress S22 (MPa)
1	Primary Model	3D; Solar Radiation; No Uplift; $E_c: 2.1E5$ kg/cm <sup>2</sup> ; $\mu:0.2$ ; $\alpha:1E-5$ /°C; $T_i:26.6$ °C.	0.415
2	Base Model	2D; Solar Radiation; No Uplift; $E_c:2.1E5$ kg/cm <sup>2</sup> ; $\mu:0.2$ ; $\alpha:1E-5$ /°C; $T_i:26.6$ °C	0.42
3	No Solar Radiation	2D; No Solar Radiation; No Uplift; $E_c:2.1E5$ kg/cm <sup>2</sup> ; $\mu:0.2$ ; $\alpha:1E-5$ /°C; $T_i:26.6$ °C	0.40
4	Variation of $T_i$	2D; Solar Radiation; No Uplift; $E_c:2.1E5$ kg/cm <sup>2</sup> ; $\mu:0.2$ ; $\alpha:1E-5$ /°C; $T_i:20$ °C	0.45
5	Variation of $E_c$	2D; Solar Radiation; No Uplift; $E_c:3.0E5$ kg/cm <sup>2</sup> ; $\mu:0.2$ ; $\alpha:1E-5$ /°C; $T_i:26.6$ °C	0.69
		2D; Solar Radiation; No Uplift; $E_c:3.5E5$ kg/cm <sup>2</sup> ; $\mu:0.2$ ; $\alpha:1E-5$ /°C; $T_i:26.6$ °C	0.83
6	Variation of $\mu$	2D; Solar Radiation; No Uplift; $E_c:2.1E5$ kg/cm <sup>2</sup> ; $\mu:0.18$ ; $\alpha:1E-5$ /°C; $T_i:26.6$ °C	0.40
		2D; Solar Radiation; No Uplift; $E_c:2.1E5$ kg/cm <sup>2</sup> ; $\mu:0.22$ ; $\alpha:1E-5$ /°C; $T_i:26.6$ °C	0.43
7	Variation of $\alpha$	2D; Solar Radiation; No Uplift; $E_c:2.1E5$ kg/cm <sup>2</sup> ; $\mu:0.2$ ; $\alpha:0.8E-5$ /°C; $T_i:26.6$ °C	0.28
		2D; Solar Radiation; No Uplift; $E_c:2.1E5$ kg/cm <sup>2</sup> ; $\mu:0.2$ ; $\alpha:1.2E-5$ /°C; $T_i:26.6$ °C	0.54
8	With Uplift	2D; Solar Radiation; No Uplift; $E_c:2.1E5$ kg/cm <sup>2</sup> ; $\mu:0.2$ ; $\alpha:1E-5$ /°C; $T_i:26.6$ °C	0.42
9	Capped Solar Radiation.	2D; Cap Solar Radiation; Uplift; $E_c:2.1E5$ kg/cm <sup>2</sup> ; $\mu:0.2$ ; $\alpha:1E-5$ /°C; $T_i:26.6$ °C	1.90
10	Filletted gallery	2D; Cap Solar Radiation; Uplift; Fillet; $E_c:2.1E5$ kg/cm <sup>2</sup> ; $\mu:0.2$ ; $\alpha:1E-5$ /°C; $T_i:20$ °C	2.15
11	Filletted gallery	2D; No Solar Radiation; Uplift; Fillet; $E_c:2.1E5$ kg/cm <sup>2</sup> ; $\mu:0.2$ ; $\alpha:1E-5$ /°C; $T_i:26.6$ °C	1.65
12	Reservoir level varying from FRL to MDDL	Base Model, with hydrostatic load varying from FRL to MDDL	0.42
13	Crack Simulation	Base Model, with 30 cm long crack on u/s and d/s faces of Top Gallery	0.354
14	Top gallery Partially plugged.	2D; Solar Radiation; No Uplift; $E_c:2.1E5$ kg/cm <sup>2</sup> ; $\mu:0.2$ ; $\alpha:1E-5$ /°C; $T_i:26.6$ °C	0.321
		2D; Solar Radiation; No Uplift; $E_c:3.5E5$ kg/cm <sup>2</sup> ; $\mu:0.2$ ; $\alpha:1E-5$ /°C; $T_i:26.6$ °C	0.531
15	Top gallery Fully plugged.	2D; Solar Radiation; No Uplift; $E_c:2.1E5$ kg/cm <sup>2</sup> ; $\mu:0.2$ ; $\alpha:1E-5$ /°C; $T_i:26.6$ °C	0.26
		2D; Solar Radiation; No Uplift; $E_c:3.5E5$ kg/cm <sup>2</sup> ; $\mu:0.2$ ; $\alpha:1E-5$ /°C; $T_i:26.6$ °C	0.44

It was concluded that the three most important parameters influencing the study are coefficient of linear expansion of concrete, modulus of elasticity of concrete and poissons ratio. It



was also felt that rather than computing the effects of solar radiation using CBRI method, it would be desirable to use actual site-specific temperatures of concrete on the downstream face for a more realistic analysis in future. Also, it was felt that as the cracking in the dam is caused by surface temperature variations, cracks in future also cannot be ruled out. So, a periodical maintenance of the dam is necessary.

Based on the results of the present study, following recommendations have been made for rehabilitation of Konar concrete dam which will be executed under the DRIP:

- The cracks may be repaired with low pressure normal grouting with cementitious materials – restricting the use of admixtures to shrinkage reduction only and not by epoxy based materials. Grouting of cracks shall be done at a time when the cracks are in fully open position i.e. during the months of summer.
- To monitor the cracks by using 2D and 3D crack meters.
- To install enough number of thermometers both on upstream and downstream side of the concrete dam to measure reservoir temperatures and downstream body temperature respectively.
- To apply a coating of anti-reflexive paint on the downstream and other exposed faces to reduce radiation effects.
- To use cementitious materials using crystalline technology which envisages materials growth with time conforming to EN-1504, Class R-4.
- Although the models with partial and full plugging of the top inspection gallery show considerable reduction in tensile stresses but this was ruled out as the size of inspection gallery is very small and because of doubts in bonding of the new concrete with the existing one and likely shrinkage.

## 4. HIRAKUD DAM

### 4.1 Brief Description of the Project

The Hirakud Dam project is built across river Mahanadi about 15 km upstream of Sambalpur town in the state of Odisha. The dam is located about 6 km from NH 6. The nearest rail head is Hirakud railway station which is about 8 km from the dam site. Hirakud Dam is one of the most prestigious projects of the country built after independence in 1957.

Hirakud Dam is a composite dam of earth, concrete, and masonry. The main dam has an overall length of about 4.8 km and spans between two hillocks of Lamdungri on the left and Chandlidungri on the right. There are two spillways in the main dam on the left and right sides located on the two channels of the main river. The main dam toe Power House is on the right flank of the main dam. The dam is flanked by two earthen dykes on the left and right sides with a combined length of about 21 km to close the low saddles. It is the longest dam in Asia having total length of 25.8 km considering dam and dykes taken together. It also has one of the largest artificial lake in Asia with a reservoir spread of 743 km<sup>2</sup> at full reservoir level.

A pictorial view showing the right bank spillway and power house is at Figure 1(a) and an aerial view of the project is shown at Figure 1(b).



Figure 1(a): Pictorial view showing the Right Bank Spillway and Powerhouse

The project provides 1, 59,106 Ha. of Khariff irrigation and 1, 08,385 Ha. of Rabi irrigation in the districts of Sambalpur, Bargarh, Bolangir, and Subarnapur. The water released through the power house irrigates another 2,51,000 Ha. of C.C.A in Mahanadi delta. Installed capacity for power generation is 347.86 MW after up gradation, through its two power houses, one at Burla at the right bank toe and the other at Chipilima, 22 km downstream of dam. Besides, the project provides flood protection to 9,500 km<sup>2</sup> of delta area in undivided districts of Cuttack and Puri.

### 4.2 Problems related to dam safety on account of upward revision in design flood

The existing spillway capacity is 42,450 m<sup>3</sup>/s (15 lakh cusec). The FRL/MWL is at RL.192.024 m (630 ft.) and the dam top level is at RL.195.68 m (642 ft.).

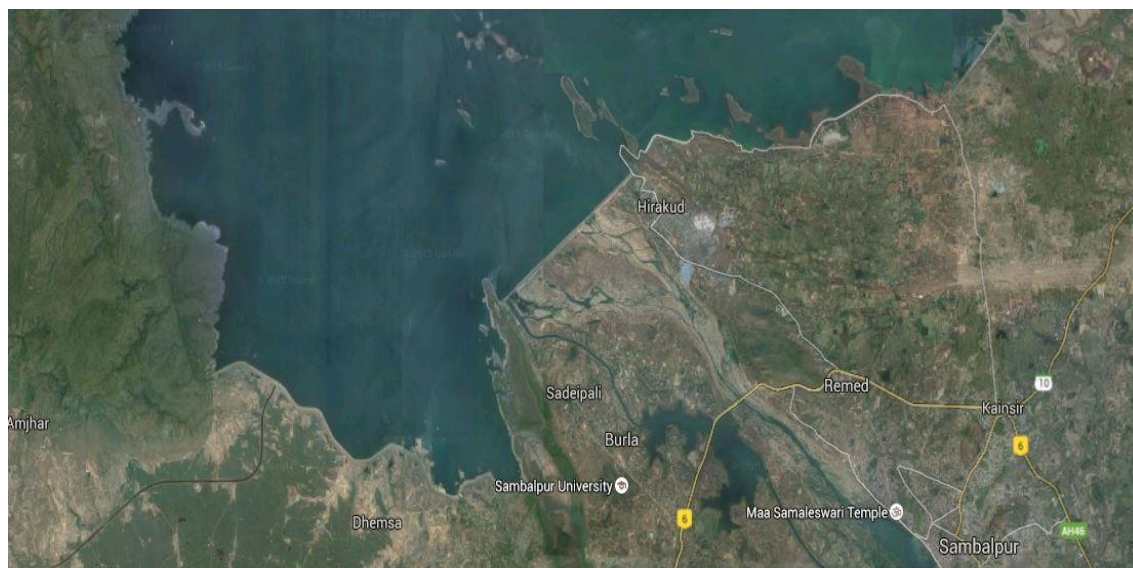

Figure 1(b): Aerial View of Hirakud Dam

The above design flood can be passed through the existing under sluices and the spillway crest radial gates as shown below:

Discharge through 64 nos. Under Sluices of size 3.658 m (W) x 6.20 m (H) (40 nos. in the left and 24 nos. in the right spillway)	=	26,885 m <sup>3</sup> /s
Discharge through 34 nos. Spillway Crest Radial Gates of size 15.54 m (W) x 6.10 m (H) (21 nos. in the left and 13 nos. in the right spillway)	=	15,565 m <sup>3</sup> /s
Total discharging Capacity (Spillway Crest Radial Gates + Under Sluices)	=	42,450 m <sup>3</sup> /s

After construction, high floods were observed at the dam site of the order of 15.25 lakh cusec (43,183 cumec) in July 1959 and 13.32 lakh cusec (37,718 cumec) in Sept 1980.

Various hydrological studies have subsequently been conducted to review the design flood and finally a PMF with a peak value of 69,632 m<sup>3</sup>/s has been accepted by Central Water Commission in 1997. Therefore, the main concern was to find a way out to pass the additional discharge, for ensuring the safety of Hirakud Dam.

#### 4.3 Various alternatives Considered

Several non-structural & structural alternatives were considered.

Non-structural Alternative of keeping a lower conservation level amounted to considerable loss in project benefits. It was seen that the conservation level was required to be lowered to El. 180 m with the existing spillway arrangements to limit the MWL to around the present FRL/MWL of El. 192.024 m. The MWL attained was about El. 192.455 m.

##### 4.3.1 From the structural alternatives, the following were identified for further study:

- (i) Raising the height of existing dam.
- (ii) Additional spillway in the left bank next to Gandhi hillock on the left bank.
- (iii) Additional spillway in the right dyke area with spill channel joining the existing Jhaun Jhor River.

- (iv) Lowering the spillway crest level with a corresponding increase in the height of spillway crest gates and
- (v) Additional spillway on the left of left spillway replacing part of existing earth dam.

The alternatives at Sl.No. (i), (iv) & (v) were dropped on account of the reasons given below.

#### 4.3.1.1 Raising the Height of Existing Dam:

It was seen that with the existing spillway arrangements the MWL attained to pass the revised flood was El. 195.694 m (642.04 ft.) which is the present dam top. If the same free-board is kept as provided in the earlier designs viz.  $642 - 630 = 12 \text{ ft.} = 3.66 \text{ m}$ , this implies raising of the dam by 3.66 m. This increase in height will have implications in the stability of main Earthen dam, Dykes, Masonry/Concrete Gravity dam/Spillways and in the designs of the existing Gates/Hoists. Various issues involved are lifting/raising of the spillway bridge, relocation of existing hoist of crest gates which is presently at El.633.75 ft. (193.167 m) etc.

Further, an Expert Committee, set up by the Govt. of India in 1970, had opined that strengthening of the dam for reservoir levels higher than El.635 ft. would be both very expensive and difficult. As such, this alternative was not pursued further.

#### 4.3.1.2 Lowering the Spillway Crest Level with a corresponding increase in height of the spillway crest gates:

This proposal involves dismantling of the crest & glacis of the existing spillway. Further there are restrictions in lowering the spillway crest because of the existing under-sluice gate operation chamber and difficulties in reconstruction of spillway piers, spillway crest & bridge besides involving new gates, hoisting arrangements etc. As such, this alternative was dropped.

#### 4.3.1.3 Additional spillway on the left of left spillway replacing part of the existing earth dam:

This proposal envisages removal of existing earth dam and re-construction of additional spillway over there. A high coffer dam, equal to the height of earth dam at that location (about 40-45 m) would be required for the purpose. This proposal was expected to be difficult from the view point of construction besides involving modifications in the main dam and was, therefore, not pursued further.

4.4 Thus the project was left with only two alternatives viz. left bank additional spillway & the right bank additional spillway. They are discussed below.

#### 4.4.1 Left Bank Additional Spillway

On the left bank, two locations for providing additional spillways were studied:

- Between Gandhi Hillock and adjacent Hillock. (Alt. 1(a))
- In the second saddle, next to Gandhi Hillock. (Alt. 1(b))

These locations are indicated on the topo-sheet in figure 2 along with the right bank alternative locations.

Out of these locations, the second location Alt. 1(b) viz. the second saddle next to Gandhi Hillock has been selected as it involves relatively lesser excavation. Initially the spillway structure was proposed in the saddle in between the hillocks. But based on geological considerations it had to be shifted about 700 m upstream of the earlier planned location to found it on good rock.

The additional spillway envisages a control structure with earthen flanks on either side con-



nected to the existing dyke/abutment. A stilling basin is proposed below the spillway followed by a long spill channel on the d/s up to the confluence with the main Mahanadi river. A straight alignment of the spill channel has been kept instead of introducing a bend in view of large discharge and high velocities involved.

#### 4.4.2 Right Bank Additional Spillway

Three alternative locations (Alternative 2a, 2b & 3) on the right dyke of the main dam were examined which have been marked on the topo-sheet at Figure 2.

Alternative-3 envisages a control structure near the start of the right dyke with a spill channel joining the existing Kuliari Jhor River which meets the River Mahanadi about 25 km d/s. As the width of this river is very less with a very limited discharging capacity, this alternative was not pursued further.



Figure 2 - Various alignments considered for the additional spillway on left and right banks

Alternative 2a & 2b envisage diversion of flood waters to Jhaun Jhor River through a spill channel emanating from control structure as shown above. This river is wider, having a width of more than 100 m as seen at crossing under NH-6. However, further widening/re-sectioning of this river may be necessary for which detailed studies would have to be carried out.

On consideration of width of these rivers, Alternatives 2a & 2b have been preferred over Alternative-3. The lengths of the spill channel involved would be about 6 km. for Alternative 2a and about 7.5 km. for Alternative 2b.

Advantage of Alternatives 2a and 2b for construction of additional spillway would be that these are likely to avoid inundation of Sambalpur Town on account of additional discharge flowing through them, as these would discharge the flood waters into River Mahanadi much downstream of Sambalpur Town. However, entire additional flood cannot be passed through the right bank alternatives in view of the limitations of the width of the river.

As Alternative- 2a involves lesser length of the spill channel (about 6 km.), it has been preferred pending detailed geological investigations.

#### 4.5 Finally selected Alternative

It was seen that it would not be possible to provide a single spillway to cater to the increase in design flood (about 27,000 cumec) either in the left bank or in the right bank. The left bank additional spillway has limitations on account of additional protection which would be required for Sambalpur city. In contrast, the right bank additional spillway has limitations of the limited capacity of Jhain Jore River from which the flood would be required to be passed.

Hence a combination of Additional Spillways in the left bank and right bank with details as under have been selected based on detailed flood routing studies:

Left Bank Additional Spillway	:	5 gates of 15m (W) x 15m (H) each
Right Bank Additional Spillway	:	10 gates of 15 m (W) x 12 m (H) each
MWL with all gates operative	:	El. 192.454 m
Discharge through L/B additional Spillway	:	9,122 m <sup>3</sup> /sec.
Discharge through R/B additional Spillway	:	13,571 m <sup>3</sup> /sec.
Total outflow	:	64,661 m <sup>3</sup> /sec.
Flood absorbed in the reservoir	:	4971 m <sup>3</sup> /sec

This combination of additional spillways on both the banks results in minor encroachment of freeboard (0.43 m) above MWL for the condition when all the gates are operative. The 1m high parapet wall on dam top has been a part of the freeboard. Also, the outflow discharge through the left bank additional spillway has been restricted to around 9000 m<sup>3</sup>/sec. with a view to restrict additional submergence of Sambalpur Town to manageable limits. The existing flood protection embankments along the river bank may need to be raised further to save the Sambalpur Town. The balance discharge will pass through the right bank additional spillway.

As the left bank Additional Spillway is located on Govt. land, it has been proposed to be taken up in Phase-1. The Additional Spillway in the right bank (just d/s of the existing dyke) involves acquisition of land for construction and therefore has been proposed to be taken up in Phase-2.

The layout Plan and maximum overflow section for Phase – 1 project are given at Figures 3 & 4.

Some of the features of Phase-1 of the project are as under:

Additional Spillway details	:	5 Gates of 15 m (W) x 15 m (H) each with 4 intermediate piers of 4 m thickness.
Length of spillway	:	91 m.
Full Reservoir Level	:	192.024 m
Maximum Water Level	:	192.454 m
Spillway Crest Level	:	177.024 m
Discharge through spillway at MWL	:	9,122 m <sup>3</sup> /sec.
Main Stilling basin invert Level	:	El. 151 m (Tentative)



Length of Stilling basin	:	71 m (Tentative)
Bed level of Spill Channel at starting point.	:	El. 162 m
Width of Spill Channel	:	120 m for a length of about 800 m and flaring to 200 m their after in the unlined portion.
Length of Spill Channel	:	1756 m (Tentative)
Longitudinal slope of Spill Channel	:	1 in 3000
Maximum TWL	:	173.8 m (Tentative)

#### 4.6 Conclusion

By providing additional spillways on the left bank (Phase-1) & in the right bank (Phase-2) it is proposed to make Hirakud dam hydrologically safe. This is planned to be carried out following an innovative approach which will not only ensure the safety of the dam but will at the same time boost tourism & recreational activities so as attract tourists to this prestigious project of the country. The left bank additional spillway (Phase 1) is proposed to be taken up under DRIP.

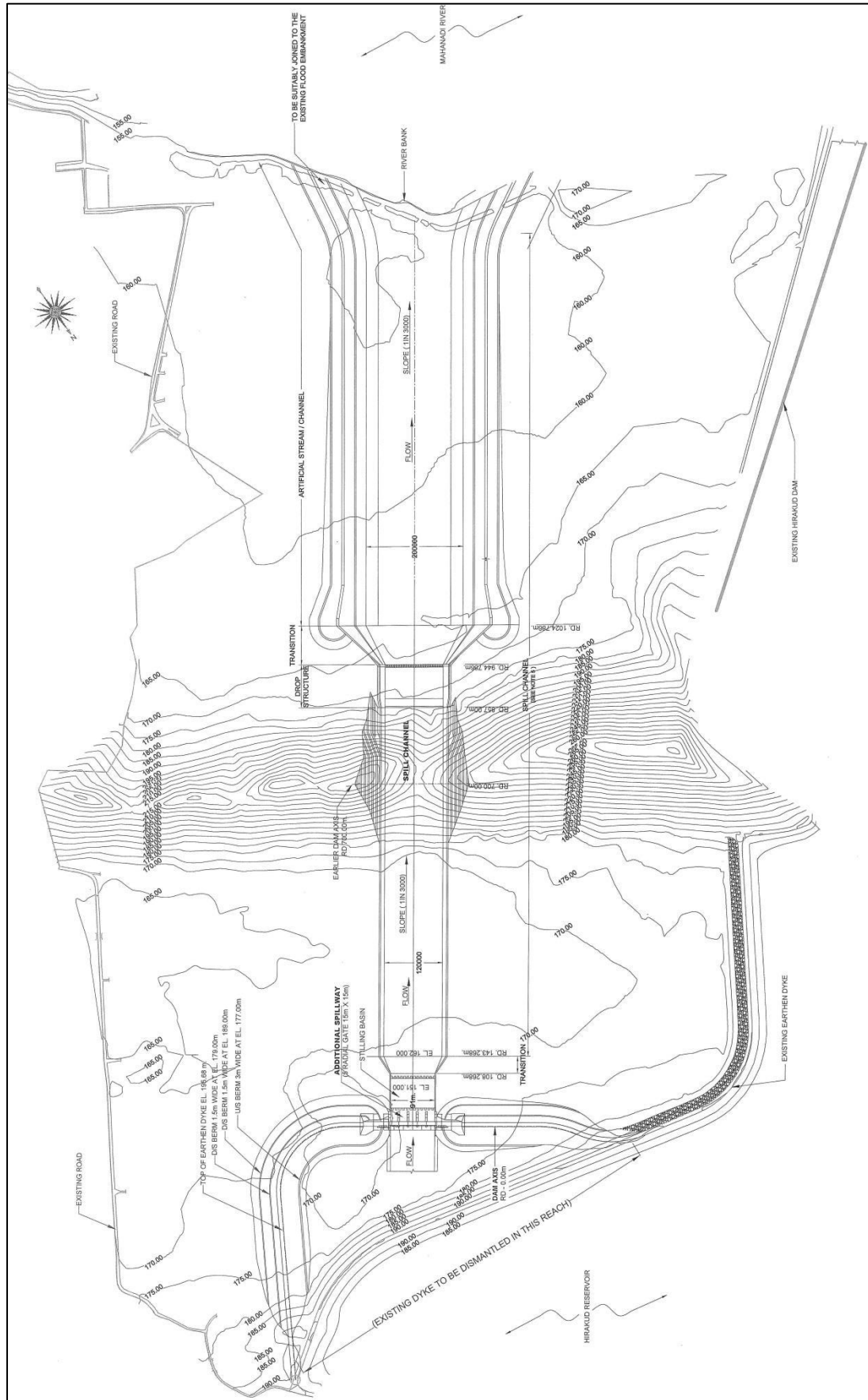

Figure – 3 Layout Plan (Phase-1) of L/B Additional Spillway

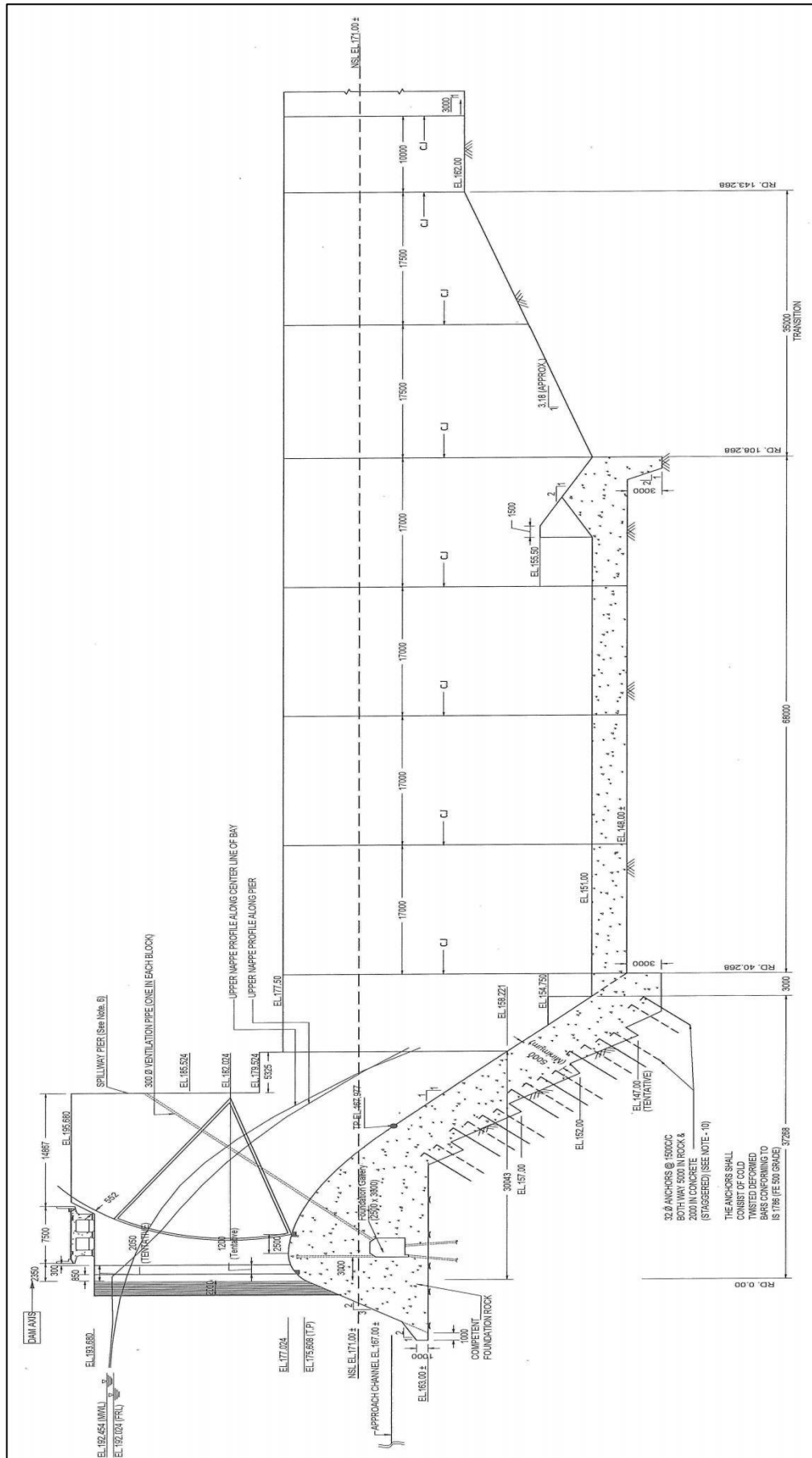

Figure – 4 Cross-Section AA of Left Bank Additional Spillway (Phase-1)

## 5. PECHIPARAI DAM, TAMIL NADU

### 5.1 Introduction

Pechiparai dam is located across Kodayar River about 43 km north-east of Nagercoil town in Kanyakumari district of Tamil Nadu. The Kodayar River rises from the Western Ghats, flows down hilly tracks, joins river Paralar and finally falls into the Arabian Sea near Thengapattinam. The catchment area up to the dam site is 167.9 sq. km. The gross capacity of the reservoir is now 150.25 Million cubic meter (MCM).

The dam was constructed in 1906. It consists of a 425.5 m long masonry dam constructed with lime surkhi mortar. The maximum height of the dam is 42 m. There is no gallery in the dam. Subsequently some modifications have been carried out from time to time. They are as under:

1. The height of the dam was increased by 2.14 m to increase the live storage capacity of the dam from 99.00 M cum to 123.00 M cum. The dam top level is now EL. +94.48 m.
2. Buttresses of 6.10 m length at 15.24 m c/c were provided below EL 76.20 m up to foundation level on the downstream face based on the suggestion of Dr. K. L. Rao. The buttresses were built with RR masonry in CM 1:4.
3. The uncontrolled surplus weir on the right flank was converted in to a regulator with 6 gates of size 12.19 m x 4.57 m each with a sill level of EL. + 87.48 m.

The main spillway now consists of a broad crested structure founded on rock having six vertical gates of size 12.2 m x 4.57 m each at the right bank. Further there is a 90 m long uncontrolled surplus weir on the right abutment beyond the main spillway with its crest at Full Reservoir Level (+92.05 m). During floods, the spillway structures function as broad crested weirs. There are also 5 no. earthen saddle dams in the project.

An upstream view of the dam is at Figure 1(a) and the layout plan is at Figure 1(b). The Maximum Non-Overflow section is at Figure 2 and the Main Spillway section is at Figure. 3.

Pechiparai dam, which is more than 100 years old, is proposed for rehabilitation under Dam Rehabilitation and Improvement Project (DRIP).



Figure 1(a) Upstream view of Pechiparai Dam

The two main aspects which were required to be studied from dam safety considerations in this dam were:

- (i) Hydrology and the adequacy of the existing surplus arrangements,
- (ii) Effect of seismicity on the stability of the dam and review of the dam stability.

The Dam Safety Expert Committee in its report of 13th February 2008, as well as the Dam Safety Review Panel in its report of 8th October 2013, had earlier suggested that structural stability of this dam should be evaluated for both static as well as seismic loading conditions. As there is no drainage arrangement to relieve the uplift pressures, it was recommended to consider full uplift while reviewing stability. The Committee also suggested to provide a drainage gallery in the concrete backing which would be required from considerations of dam stability.



Fig.1(b) – Layout of the dam

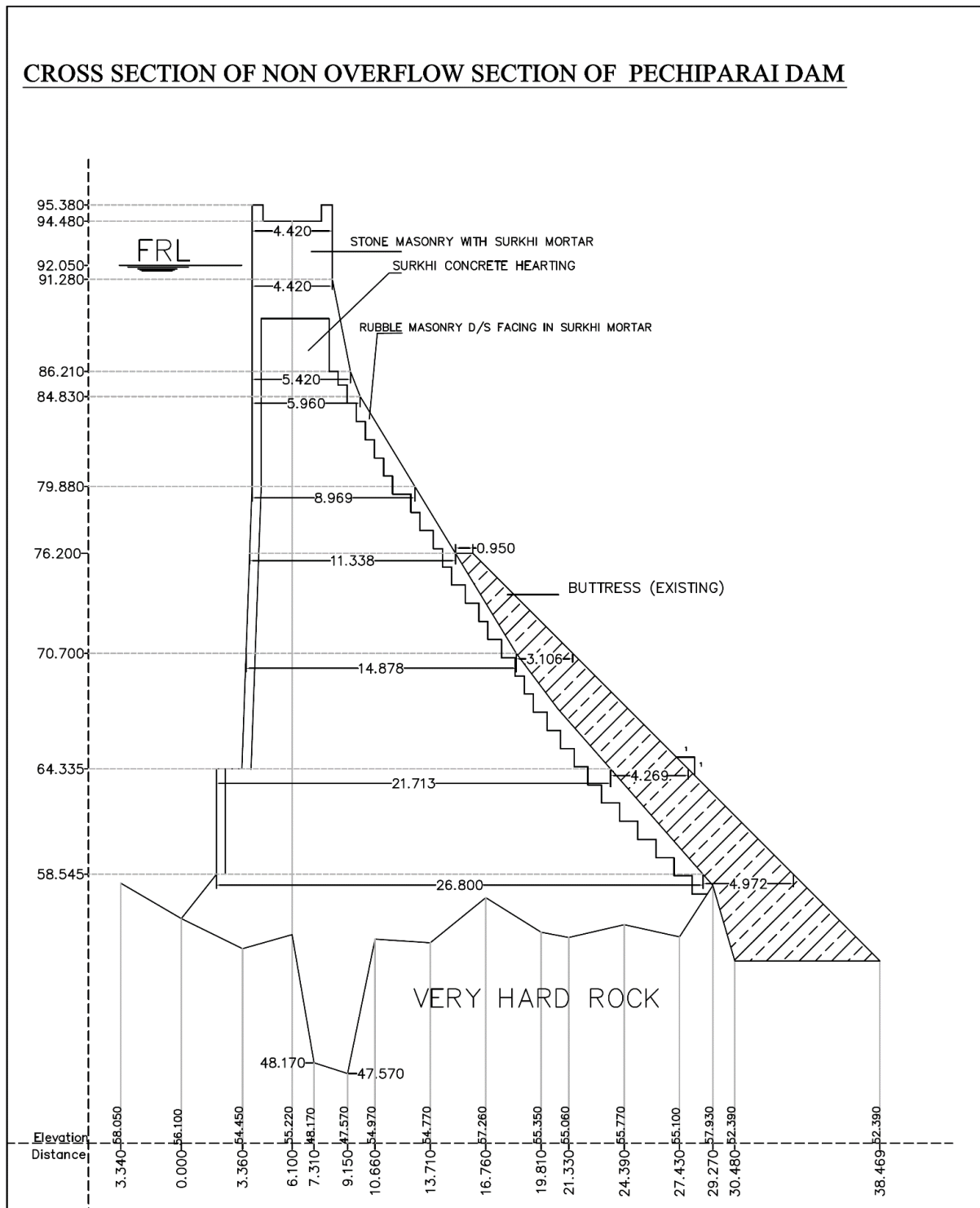

Figure 2 – Maximum Non-Overflow Section with d/s buttress



## EXISTING SPILLWAY SECTION OF PECHIPARAI DAM

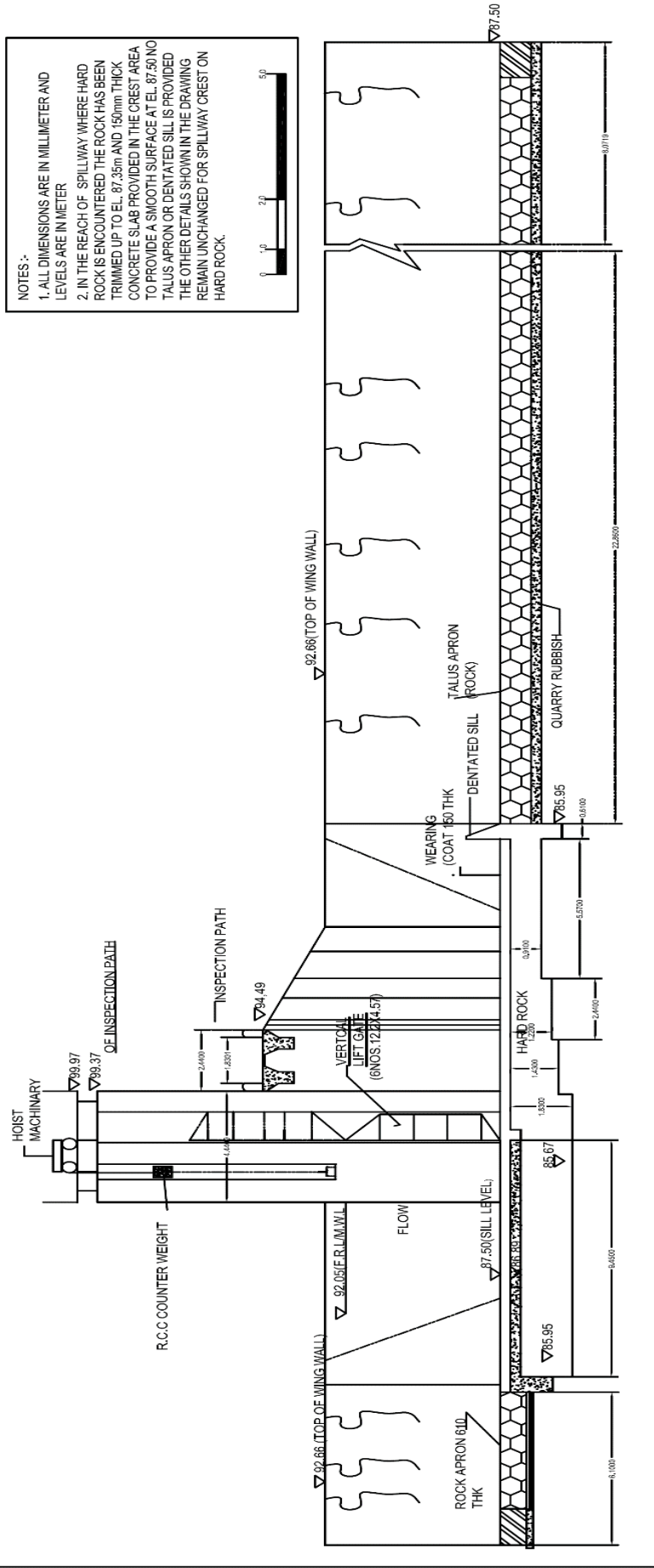

Fig.3 Main Spillway Section

## Hydrology

The existing design flood of the dam is 1104 cumec. The hydrological review study of Pechiparai dam was carried out earlier by the project authorities through consultants in 1994.

The severe rain storm of 13-14 November 1992 which yielded widespread heavy to very heavy rainfall over a large number of stations in Tamilnadu was initially considered. The Standard Projected Storm (SPS) value from Depth-Area-Duration (DAD) curve of the storm of date 14.11.92 for Pechiparai dam showed 357 mm depth. The SPS for the catchment was required to be maximised to arrive at PMP value from dew point temperature consideration. For this purpose, the dew point temperature of Indian Meteorological Department (IMD) observatory, Tuticorin which lies on the inflow side of the project area was considered.

The Probable Maximum Precipitation (PMP) value after applying Moisture Adjustment Factor (MAF) is 430 mm. But the PMP from Indian Institute of Tropical Meteorology (IITM) generalised map gives a value of 500 mm. Hence the one-day PMP value of 500 mm was finally adopted as the design storm.

The Design flood study of Pechiparai dam was carried out by the project authorities through consultants in 1994 adopting the one-day PMP value of 500 mm by the hydro-metrological approach. The PMF hydrograph derived with a peak value 5238 cumec was recommended. The same study was recommended to be adopted by Central Water Commission (CWC) in the present review also.

### 5.2 Flood Routing

The flood hydrograph with the peak value of 5238 cumec is routed through the existing surplus arrangements having 6 gates of size 12.2 m x 4.57 m each and through the 90 m length of ungated surplus weir with its crest at +92.05 m (FRL) located at the right end of the dam.

The existing surplus arrangement were found to be inadequate to pass the Probable Maximum Flood (PMF) hydrograph raising the reservoir level to +93.74 m against the designed Maximum Water Level (MWL) of 92.05 m leaving a free board of 0.74 m. (i.e. 1.69 m above the designed MWL). Bureau of Indian Standards provide for a minimum freeboard of 1.0 m above MWL for masonry/concrete dams and 1.50 m for embankment dams.

### 5.3 Additional Surplus Arrangements

The site was inspected to explore the possibility of providing an additional surplus arrangement.

It was decided to dismantle a part length of the existing 90 m long saddle ungated overflow section to provide an additional gated spillway. The proposed additional spillway will be about 60 m long with crest level at El. 89.30 m and it shall have 8 gates of size 5m x 2.72 m each to have a minimum freeboard of 1m above revised MWL. As per the bore log details, hard rock exists at an elevation of +87.0 m hence it is proposed to provide a body wall with its foundation at the hard rock level of +87.00 m with crest at El. +89.30 m. The plan and cross-section of the Additional Spillway are at Fig. 4 and 5 respectively.

With this additional provision, the inflow hydrograph with a peak value of 5232 cumec is attenuated to 1986 cumec leaving a free board of 1.06 m.

However, in the 5 no. existing earthen saddle dams a 1.0 m high solid parapet wall is planned to be constructed from freeboard considerations.

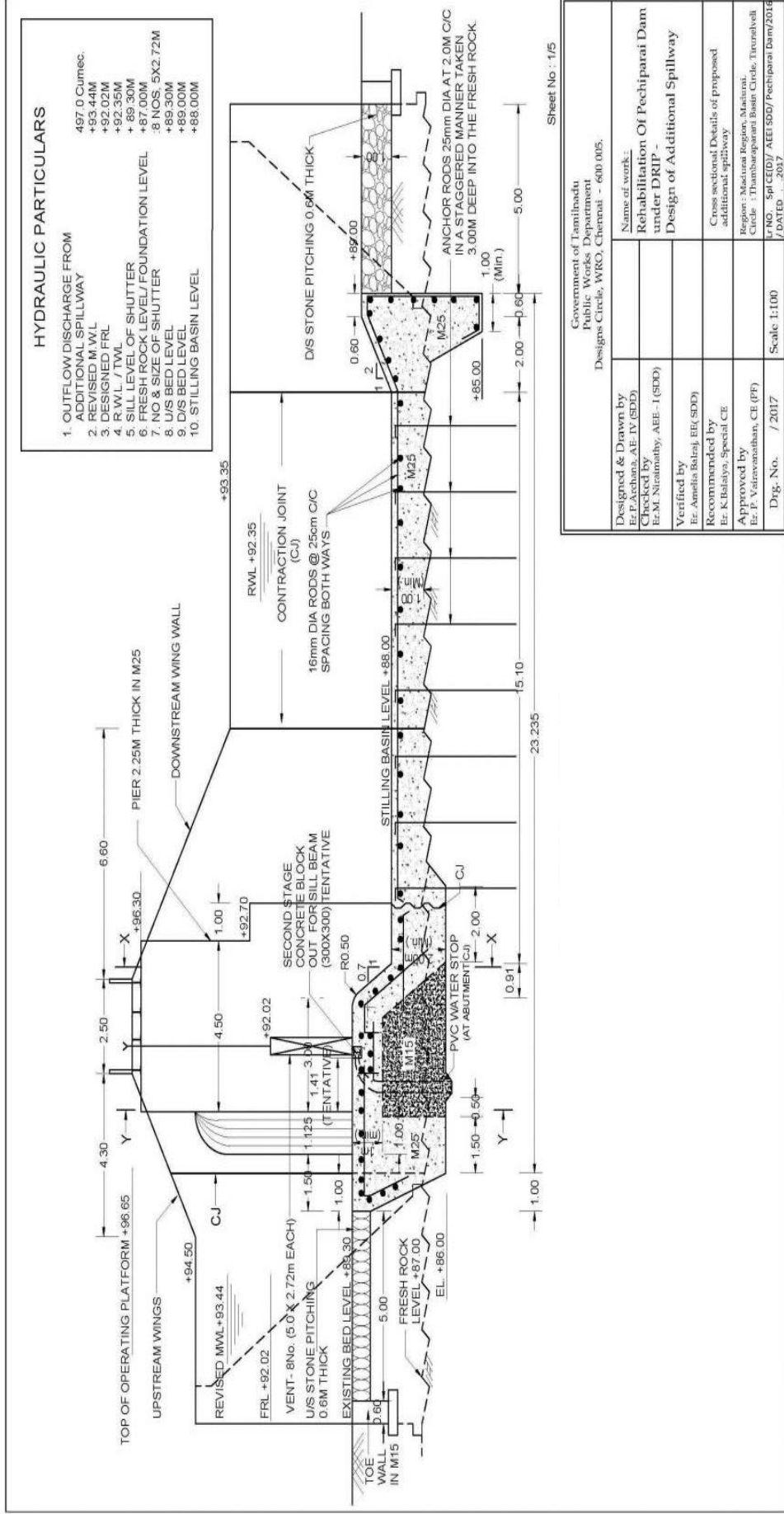

Fig. 4 Cross-Section of Additional Spillway

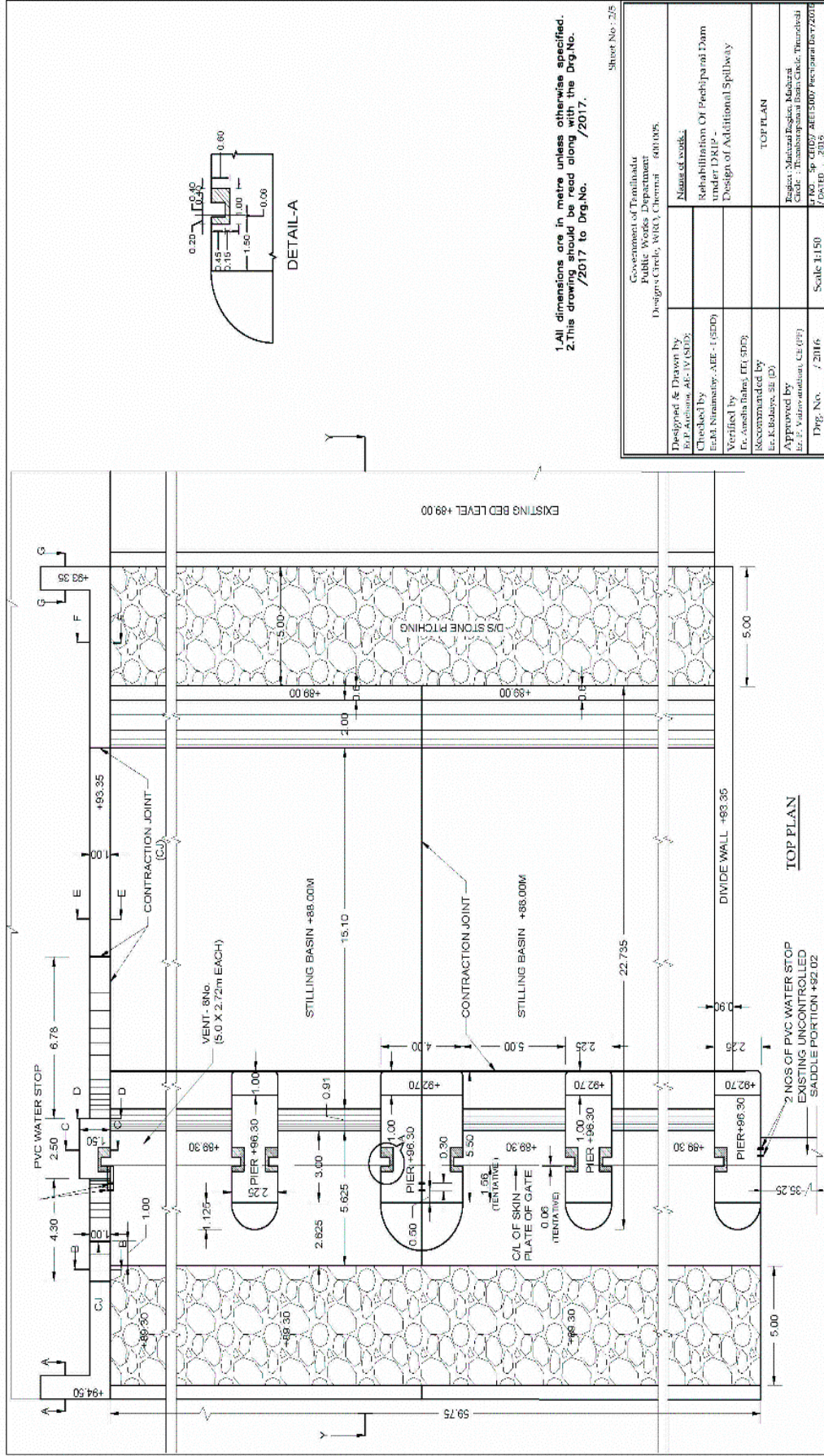

Fig. 5 Plan of Additional Spillway

#### 5.4 Effect of Seismicity on the Stability of the Dam

The masonry dam (425 m long) was constructed with lime surkhi during 1906. Its maximum height is 42 m. The dam section was designed and constructed with the technology more than 100 years old. The Non-Overflow section has various slopes on the downstream changing in every 10 ft. height; probably its stability would have been checked at each 10 ft. height as per the then available stability criteria. No gallery is provided in the dam. Because not much knowledge was available regarding earthquake resistant designs at that time, it was presumed that the seismic loading would not have been considered in the design.

Presently, it is an essential requirement to consider seismic loading in stability analysis of all dams. Further considering the capacity and height of Pechiparai dam it was felt necessary to assess the ability of this dam to withstand seismic force as per present standards. This was also emphasised by the Dam Safety Expert Committee which visited the dam in 2008.

The dam falls under zone III of Indian Standard IS 1893. The earthquake forces are required to be calculated as per IS 1893-1984 for pseudo-static analysis. Stability analysis of the deepest dam section as existing was carried out based on IS 6512-1984 for all loading conditions considering full uplift because the drainage gallery is absent.

It was found that the existing profile of non-overflow section is not adequate for the Load Combination of Reservoir at FRL with Earthquake and full uplift. Hence it is necessary to strengthen the existing dam by providing backing concrete on the downstream face. At the deepest section the d/s backing concrete will provide an additional base width of about 10.10 m. The total length of backing concrete in plan is about 384 m.

The existing dam section in such cases of dam strengthening is assumed to carry the hydrostatic forces corresponding to the bonding level i.e. the reservoir level at which the strengthening works are proposed to be undertaken besides its own self weight whereas the full dam section is assumed to carry the balance additional hydrostatic forces and earthquake forces. Also it was decided to have a drainage gallery in the newly proposed downstream backing portion.

The stability analysis was carried out for all the following conditions stipulated in IS: 6512-1984.

1. Reservoir empty without Earthquake
2. Reservoir at FRL with Normal uplift (Full uplift in this case)
3. Reservoir at revised MWL with Normal uplift (Full uplift in this case)
4. Reservoir empty with Earthquake
5. Loading condition at 2 above but with Earthquake
6. Loading condition at 3 above but with extreme uplift (same as loading condition 3 above in this case)
7. Loading condition at 5 above but with extreme uplift (same as loading condition 5 above in this case)

For all loading conditions, it was seen that with the proposed downstream backing concrete the stresses developed were within permissible limits.

##### 5.4.1 Details of downstream backing concrete

Backing concrete is proposed over the downstream slope of the existing section for a length of 384 m along its alignment in plan.

The average width of the backing concrete at the base in the deepest section is about 10.10 m. It is proposed to provide a drainage gallery in the backing concrete portion. Backing



concrete with a width of 7.0 m at an elevation of +79.88 m and another berm at +61.43 m with a width of 3.0 m is proposed to accommodate the drainage gallery along with a downstream slope of 0.8:1.

Shear keys have been proposed at about 3m interval along the height of the dam at an elevation of El.55.430 m, El.58.430 m, EL.61.545 m, El.65.295 m, El.67.545 m, El.69.795 m and El.73.545 m for proper bonding between old and new concrete.

Anchor rods of 20 mm dia. HYSD bars are proposed in a staggered manner at 1/3 distance between two shear keys perpendicular to the inner face.

Figure 6 shows the deepest Non-Overflow Section with the proposed downstream backing and gallery. Also a pictorial d/s view is given below with buttresses constructed earlier.

#### 5.4.2 Details of drainage gallery

The drainage gallery of size 1.5 m x 2.25 m is proposed in the backing concrete part. The gallery is proposed up to which adequate cover is available in the backing concrete. So, the gallery is proposed for a length of 249 m from LS 54 m to 303 m. The floor level of the gallery is fixed to allow a minimum cover of 3m from the foundation grade as stipulated in IS 12966-(Part 1)1992. The floor level at the deepest section is at an elevation of +57.430 m, stepping up along the rock profile up to El. +75.880 m on either side.

Because adequate cover is not available up to Ch. 54 m and beyond Ch. 289 m, the drainage gallery is proposed in the reach between Ch. 54 m & 289 m. However, the total length of backing concrete proposed is 384 m.

Half Round porous concrete drains of 20 cm diameter (dia.) at 3 m center to center (c/c) have been proposed along the interface of old and new concrete for drainage purposes. The seepage water will be drained into the proposed drainage gallery from where it would be suitably disposed of in the downstream.

Drainage holes of 10 cm dia. have been proposed at the floor of Drainage gallery. Also formed drainage holes are proposed from the roof of the backing concrete extending upwards.



Downstream view of the existing dam with buttress



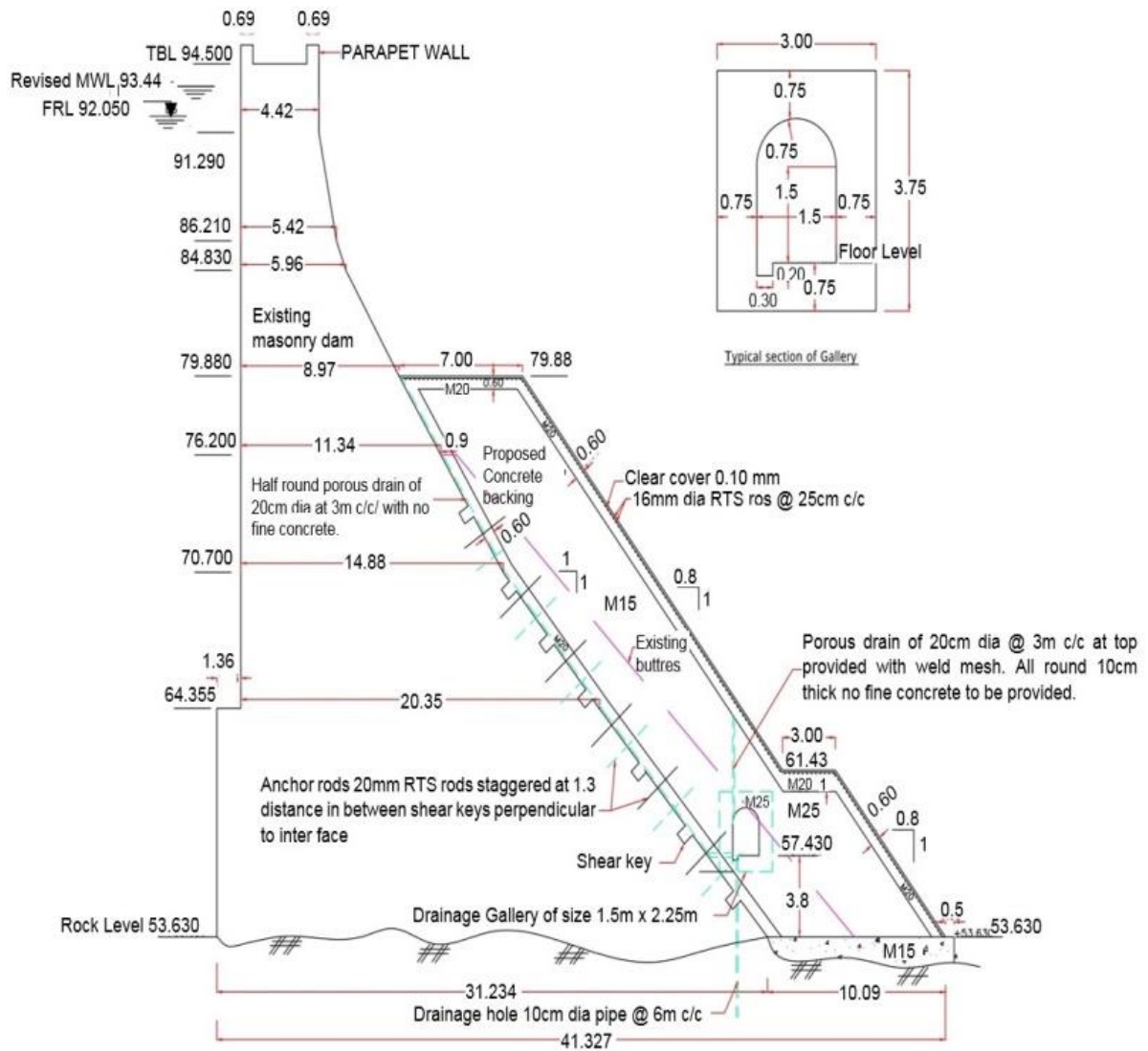

Figure 6: Deepest Cross section of Dam with proposed downstream concrete backing and Drainage Gallery

## 6. KADAMPARAI DAM, TAMIL NADU

### 6.1 Introduction

Kadamparai dam of Tamil Nadu Electricity Board (TNEB) was completed in 1983. It is located in Coimbatore District of Tamil Nadu and is operated in conjunction with Upper Aliyar dam which is located below Kadamparai dam and forms part of the 400 MW Kadamparai pumped- storage project.

The dam is a composite structure, consisting of a central masonry spillway with earthen embankments on both flanks. The Masonry dam is 67 m high and 478 m long, with a central spillway, a scour vent tower and a foundation gallery. The transverse contraction joints are spaced at 40 m intervals in the Non-Overflow section, at approximately 37.5 m intervals in the spillway and 11 m interval near the scour vent. Seepage is collected in the foundation gallery from drainage holes provide in the dam and foundation rock.

The dam is used as a fore bay reservoir of the Kadamparai pumped-storage plant, which has an installed capacity of 400 MW. The gross storage capacity is 26.85 MCM. As a result of the pumping operation, the water level fluctuates by about 4 to 5 m (maximum).



### 6.2 Seepage and remedial measures

First impounding of the reservoir began on 16 July 1984. At that time, the maximum observed seepage was only 1120 l/min. Most of the seepage was observed through shafts/drainage holes at the contraction joints. This seepage measured during first filling was equivalent to 40 per cent of the allowable seepage through the entire dam face. During the first year of operation of the reservoir, seepage through the dam was within acceptable limits. But from around 1995, seepage rates gradually began to increase until the autumn of 2002. Seepage sources included:

- Distributed seepage entering through the masonry dam body from deteriorated joints between masonry stones on the u/s face and cavities formed in the masonry;
- Concentrated seepage at contraction joints between monoliths; and,
- Seepage through the foundation rock.

Seepage through the embankment wrap around section into or around, the gravity section was estimated to be extremely small compared with the other identified paths.

### 6.3 Details of remedial measures taken until 2002

Between 1990 and 1996, packing and upstream pointing was carried out at selective locations on the upstream face where leakage had been identified, and vertical drilling and grouting was done from the top of the dam.

Then from 1999 to 2000, underwater treatment of the leaking areas was done on the u/s face using chemicals and cement, and this reduced the leakage from 4200 to 800 liters/min. Subsequently the chemical treatment proved to be totally unsuccessful, because it got detached from the masonry and got peeled off. Chemical grout came out through the drainage gallery, leaving more cavities inside the body of the masonry dam and the leakage increased again.

Repairs during 2002 somehow controlled the increase in seepage. But from the autumn of 2002 until 2003, despite additional packing and u/s pointing, the seepage rates increased drastically. By February 2003, the seepage through the vertical shafts/drainage holes had reached 11800 liters/min at reservoir level of El. 1140.55 m (FRL is El.1149 m).

### 6.4 Methodology for the proposed rehabilitation

As the conventional methods adopted had failed at Kadamparai, advice of various expert organizations was taken for a long lasting solution. Dr. A.R. Santhakumar, the then Dean of Civil Engineering at the Anna University, Chennai after making a field visit suggested application of Geo-membrane on the upstream face of the masonry dam to control seepage.

Based on his advice search was undertaken to locate companies which might be able to undertake such a remedial work.

As TNEB was not familiar with the use of Geo-membrane technology for controlling/stopping leakage in dams, was requested to make a site visit to determine whether the above technology could be applied at Kadamparai. After detailed discussions and site inspection by international reputed companies/ experts, it was concluded that Geo-membrane technology would provide a long-term solution, and it was therefore decided to adopt a PVC geomembrane system.

Based on observations of leakage, and taking into account the cost/benefit ratio and the need to limit the outage time, TNEB decided to install the new waterproofing system only in the exposed area of the central structure, and no repair work was considered necessary for the two portions of the gravity section covered by the sloping wrap-around of the earthen embankment sections. Also, no excavation was planned to expose the foundation level.

In November 2003, an international tender was issued for rehabilitating the dam and to stop the leakage. Based on the data of successful precedents, acquired by worldwide experience and as reported in international literature, an exposed Polyvinyl Chloride (PVC) Geo-membrane, mechanically anchored and drained, was specified in the tender. According to data available from ICOLD, the use of a PVC Geo-membrane was the most frequently adopted solution for the rehabilitation of gravity dams. The tender specified a monitoring system for the PVC geomembrane, and required evidence of previous successful applications of the proposed waterproofing system at similar projects.

The contract was awarded in July 2004.

To reduce concentrated stresses and risk of puncture to the Geo-membrane due to protruding surfaces of stone masonry on the u/s face, an anti-puncturing layer of a thick, 2000 g/m<sup>2</sup> pure polyester fiber needle punched Geo-textile mechanically anchored to the u/s

face of the dam was proposed. The waterproofing liner proposed was a geo-composite, consisting of an impervious flexible PVC Geo-membrane 2.5 mm thick, heat coupled during extrusion to a non-woven, needle-punched 500 g/m<sup>2</sup> Geo-textile, which provides drainage and further anti-puncture protection. The PVC Geo-composite would be exposed to the water of the reservoir and secured to the dam body by a patented fastening system, consisting of vertical anchorage lines on the upstream face, which also work as free-flow drainage conduits. Further a watertight perimeter anchorage was proposed which consists of submersible perimeter seals which are water-tight at the foundation level, spillway, openings and trash racks of the scour vent tower. These were planned with an 80 x 8 mm stainless steel flat profile which compresses the PVC Geo-composite against the subgrade. Beneath the flat profile, the subgrade is first smoothed by a layer of reinforced shotcrete with a sub-sequent layer of bedding epoxy resin installed. The perimeter seals above maximum water level (dam crest, including scour vent tower) are watertight against rain and waves, and are made of 50 mm x 3 mm stainless steel flat profile which compresses the PVC Geo-composite against the dam/sub-grade; the sub-grade at these locations is also smoothed by a layer of epoxy mortar.

The vertical anchorage lines on the upstream face were planned to be placed at regular 5.7 m intervals and consisted of two components (profiles) designed to provide a tensioning effect on the PVC Geo-composite (see fig. 1, 2, 3). The vertical anchorage system was to be covered by a Carpi patent which incorporates a face drainage system to monitor the efficiency of the liner.

The 'Zone Quantification Method', developed in the USA to predict seepage quantities after installation of the waterproofing system, was planned to be used to ensure reduction of seepage in the area where the waterproofing Geo-composite was planned to be installed. This evaluation included analyses of the available seepage records to quantify flow through various zones of the dam and foundation, estimate zone seepage parameters and predict seepage quantities versus reservoir pool level after installation of the Geo-composite system on the upstream face of the dam.



Figure: 1- The stone masonry blocks at the upstream face before being covered by Geo-membrane.

## 6.5 Construction works

Starting in October 2004, TNEB undertook civil works including:

- Additional drilling and grouting from the crest adjacent of the vertical shafts/drainage holes;

- Removal of sediment and cleaning the area near the heel and exposing the foundation rock; and,
- Grouting at the heel below the lowest limit of the Geo-membrane liner.

In January 2005, installation of the Geo-membrane waterproofing system began, and the job was completed by 2nd May. Impounding then began.

The design of the waterproofing system avoided extensive civil works for preparation of the upstream surface. After the removal of debris and sediments from the heel area, TNEB repositioned and sealed any detached or loose stone blocks, and did some restoration work on the deteriorated material, filling in the joints in the masonry on the u/s face.

The 12 vertical contraction joints extending from the crest down to the heel were considered to be points of very high risk for water bypassing the watertight perimeter seal of the Geo-membrane system and there after crossing the vertical contraction joints (especially when there is no proper concrete block out for accommodating the u/s water stops or due to failed water stops). At those locations, a localized treatment on the lower part of the joint near to ground level was carried out to minimize water infiltration from below the watertight perimeter seal through the 12 joints. The treatment, was discussed with various national and international grouting experts and was defined based on observations during the previous grouting works, which showed that water bypassed the water stop as a result of the general permeability of all the joints between the masonry stones surrounding the water stop. Holes were drilled horizontally into the joints approximately 20 cm above ground level, to reach and slightly penetrate the asphalt well in front of the copper water stop. Cement grout was injected in the cleaned hole, and when the grout was cured, the hole was sealed with a high strength non-flow epoxy bedding mortar.



Figure: 2- The vertical anchorage profiles are installed on the u/s masonry dam face of Kadamparai dam at 5.7 m c/c. The anti-puncture geotextile is placed on the dam face between the profiles.

The first components (inner profiles) of the vertical anchorage system were installed directly over the masonry. To protect the Geo-composite against puncturing by the sharp masonry stones, a 2000 g/m<sup>2</sup> geotextile was installed on the masonry surface between the profiles.

The Geo-composite sheets were lowered from the dam crest and positioned on the upstream face by crews working from suspended platforms. The sheets were then secured and tensioned over the dam face by the second component (outer profiles) of the vertical anchorage assemblies.



At the bottom, the Geo-composite was confined by a double seal which was watertight against water; a primary seal placed almost at the bottom of the upstream face and a secondary seal placed underneath it. To achieve even compression assuring water tightness, the perimeter seal must be made on a plane surface. On the masonry surface, where large offsets of the masonry would have made it impossible to achieve even compression, a layer of shotcrete, and levelling mortar was provided to even the surface in the area of the seal. The levelling layer was installed at both bottom seals, at the trash racks, at the scour vent tower, and at both sides of the spillway. No levelling shotcrete was necessary where the seals are on concrete (the spillway).

At all the seals, both submersed and those above water level, an 80 x 3 mm EPDM rubber gasket and stainless steel splice plates were provided to ensure even compression.

## 6.6 Monitoring system

The efficiency of the Geo-composite system is checked by monitoring the water drained by the four separate compartments into which the face drainage system has been divided. Two upper compartments, one at each side of the scour vent tower, collect drainage water from the upstream face down to the primary bottom seal. Two lower compartments, one at each side of the scour vent tower, collect water between the primary and secondary bottom seals.

Drained water travels by gravity through the face drainage layer (the geotextiles and vertical anchorage profiles) to the bottom collection conduit made by a double layer of a highly trans-missive Geo-net placed at the bottom of each compartment. Each compartment has a transverse discharge pipe to the gallery, where the drained water is monitored.

To provide a further control in case there is water behind the Geo-composite each of the two upper compartments are equipped with a piezometer which can be read from the foundation/inspection gallery. In addition, to locate the area where there is leakage, an optical fiber cable system (heat pulse method) has been installed behind the Geo-composite. This system is based on the difference in temperature caused by leaking water and signaled by the optical fiber cable.



Figure: 3- The waterproofing PVC Geo-composite is installed over the Geotextile and fastened with the second component of the patented vertical anchorage system.

## 6.7 Performance and cost

Impounding of water began on 12 April 2005. At the reservoir level of El.1140.00 m with head 9 m below the FRL the rate of leakage is reported to be 63 litres/min. Before installation of the Geo-composite, the rate of leakage at that same pool elevation was 28000



litres/min. The maximum predicted rate of leakage at full supply level (El. 1149 m), as calculated by the Zone Quantification Method, is 1400 litres/min.

Installation was completed six weeks ahead of schedule, allowing for the generation of power earlier than expected.

The total price of the rehabilitation project was Rs.12.48 crores (about US\$ 2.9 million) for an installation covering more than 17300 m<sup>2</sup>. The price includes design, supply, installation, equipment, quality control, management, commissioning, patent fees, and 10 years warranty.

The installation of the waterproofing system, including the monitoring system, was completed in 3 months, and six weeks ahead of schedule.

## 6.8 Conclusion

The rehabilitation of Kadamparai dam using an exposed geomembrane was the first project of its kind in India, and has proved to be an effective way of reducing seepage in dams and hydraulic structures.

To control seepage in masonry dams similar rehabilitation works viz. provision of Geo-Membrane are being carried out in Servalar dam of Tamil Nadu under the DRIP project.

Geomembrane is also proposed for control of seepage in Upper Bhawani dam of Tamil Nadu and Annathodu dam in Kerala.

## 7. BHAKRA DAM

### 7.1 Introduction

Bhakra Dam is a 740 ft high straight concrete gravity dam constructed on river Sutlej in Himachal Pradesh. It is being maintained and operated by Bhakra Beas Management Board (BBMB). It has a centrally located overflow spillway for passing flood through 4 number radial gates. The spillway discharges into 420 ft long stilling basin, the maximum depth of which is 83 ft. A central training wall divides the spillway into 2 bays each 130 ft wide. The spillway is curved in the dam portion and sloping/horizontal in the apron portion. The thickness of concrete in the apron floor varies from 20 ft to 40 ft. A d/s pictorial view of the dam is at Figure 1. The general layout and maximum section of spillway is illustrated in Figure 2(a) and Figure 2(b) respectively.



Figure 1 – A Downstream pictorial view of Bhakra Dam

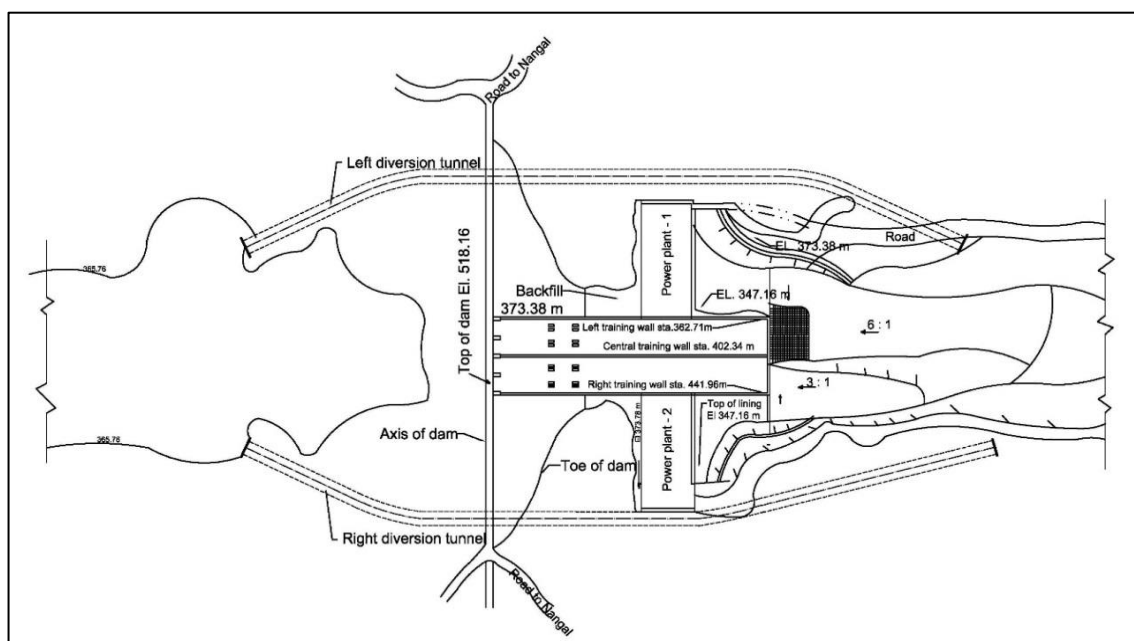

Figure 2(a) – General Plan of Bhakra Dam

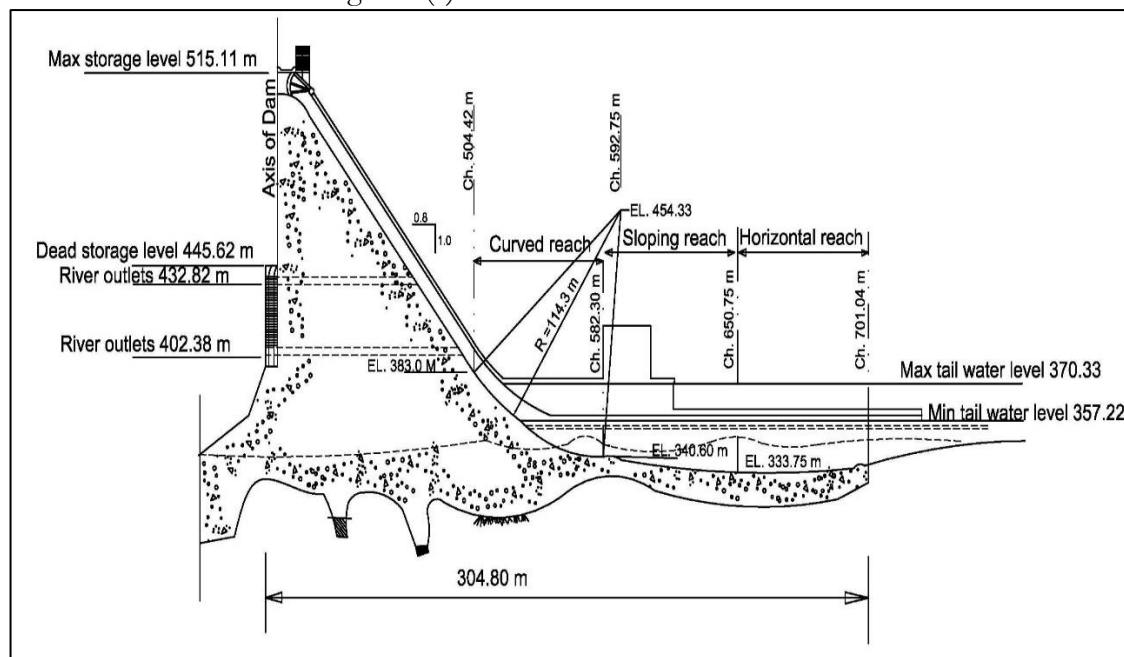

Figure 2(b) – Maximum Spillway Section

Bhakra Dam spillway Apron floor has been damaged due to abrasion caused by churning action of boulders, concrete lumps and other metallic pieces that may have been sucked into the stilling basin from the downstream river bed or those which might have fallen in the stilling basin pond during the construction stage of the project.

The extent of damage was found upto 16 inches in depth. Various methods such as under water concrete, cellular coffer dam method and pneumatic caisson technique were considered for repairing the damaged stilling basin floor. After careful analysis of various aspects involved such as usefulness, economy and effect on power generation etc. the pneumatic caisson technique was found to be more practical and best suitable to the conditions prevailing at Bhakra and was ultimately put into practice. The scheme was furnished by M/s Premier Consultant and was further developed by the project engineers to suit site conditions.

## 7.2 Damage to Spillway Apron

During construction period, undesired material fell into the stilling basin. A lot of concrete and reinforcement also fell into the stilling basin at the time of failure of central training wall block in 1958 and hoist chamber collapse in the year 1959. A lot of bed material/boulders were also sucked into the stilling basin from downstream river bed. All this undesirable material caused erosion/abrasion of apron floor by its churning action on account of heavy flow of water in subsequent floods of 1959, 1960 and 1961.

In 1962, the apron floor was cleared of debris/foreign material with the help of divers who reported damage to the floor. A thorough inspection of the bed after clearance of above material revealed general abrasion of the entire floor which varied up to 16 inches. The extent of damage was more pronounced near the side walls as compared to area away from walls. The extent of damage in apron floor is illustrated in Figure 3.

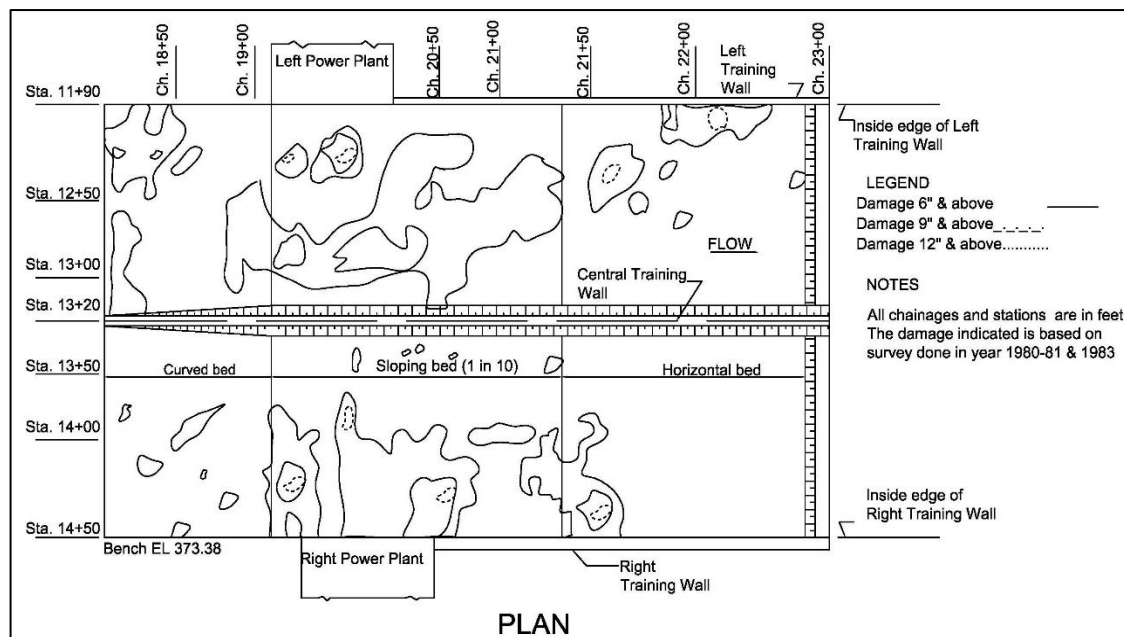

Figure 3 – Damage in Left and Right Spillway

For repairs of local nature as well as areas of extensive damage, various methods such as underwater concrete, open vertical circular shaft, pressurized diving bell, pneumatic caisson method and cellular coffer dam methods were considered as a result of studies undertaken in consultations with Indian and Foreign firms on the advice of Experts Committee on Spillway Repairs. Since all this was to take time, as a first step underwater concreting using 7000 psi strength concrete was done in 1963 with the help of divers in the area where the reinforcement of bed was exposed. The spillway was again operated in 1973, 1975 and 1979 and on subsequent inspection it was observed that the concrete placed by divers did not give satisfactory results due to lack of proper bond between new and old concrete as a result of which some concrete was washed away with the operation of spillway, increasing the damage further due to churning action.

### 7.3 Method Adopted For Repair

In view of the unsatisfactory results of underwater concreting by divers, pneumatic caisson method and cellular coffer dam method were given a serious thought. After careful consideration of all aspects of safety of dam and un-restricted power generation, pneumatic caisson method was ultimately selected and adopted for repair and inspection of the spillway floor after trial. Systematic repair of the floor of stilling basin by this method was started in February, 1984.

#### 7.3.1 Technique

The method involves placing a double walled steel caisson filled with sand and water ballast, on the damaged/eroded floor. The water from inside the caisson is expelled by the application of high pressure air from the top of caisson to facilitate repair in dry conditions. The eroded surface is thoroughly cleaned of all debris/sand and other material and given epoxy treatment for achieving a good bond between new concrete with old damaged concrete. After completing the repair and allowing setting time to concrete, the caisson is shifted to adjacent unrepaired area for taking up repair. By adopting this scheme repair is carried out patch by patch. The shifting of the caisson from one patch to another is done with the help of floating structure called sinking set. The entry/exit of men and material in-

to the pressurised caisson for undertaking repairs is regulated through an Air Lock which is a pressure vessel with different compartments.

### 7.3.2 Equipment

The main components of the equipment deployed for repair in this method are; Pneumatic Caisson, Air Lock, Sinking Set, Pneumatic Plant, Revolver Crane and Electrical equipments.

#### 7.3.2.1 Pneumatic Caisson

It comprised of 13 units (27m high) air sealed double walled square structure. The bottom unit of 3 m height is having outside dimensions as 8 m x 8 m at top and 9.5 m x 9.5 m at bottom. The caisson has 4 m x 4 m central dredge hole which flares out at bottom to repair 9.2 m x 9.2 m area. The remaining 12 units of 2 m height are having outside dimensions 8 m X 8 m and central dredge hole as 4 m X 4 m. The inside vertical 4 m x 4 m central dredge hole is covered with hatch cover. To keep the pneumatic caisson vertical for repair in different reaches according to profile of apron floor, a toe plate matching the floor profile is fitted at the bottom unit of the caisson. The general arrangements of the Pneumatic Caisson and Sinking Set is illustrated in Figure 4.

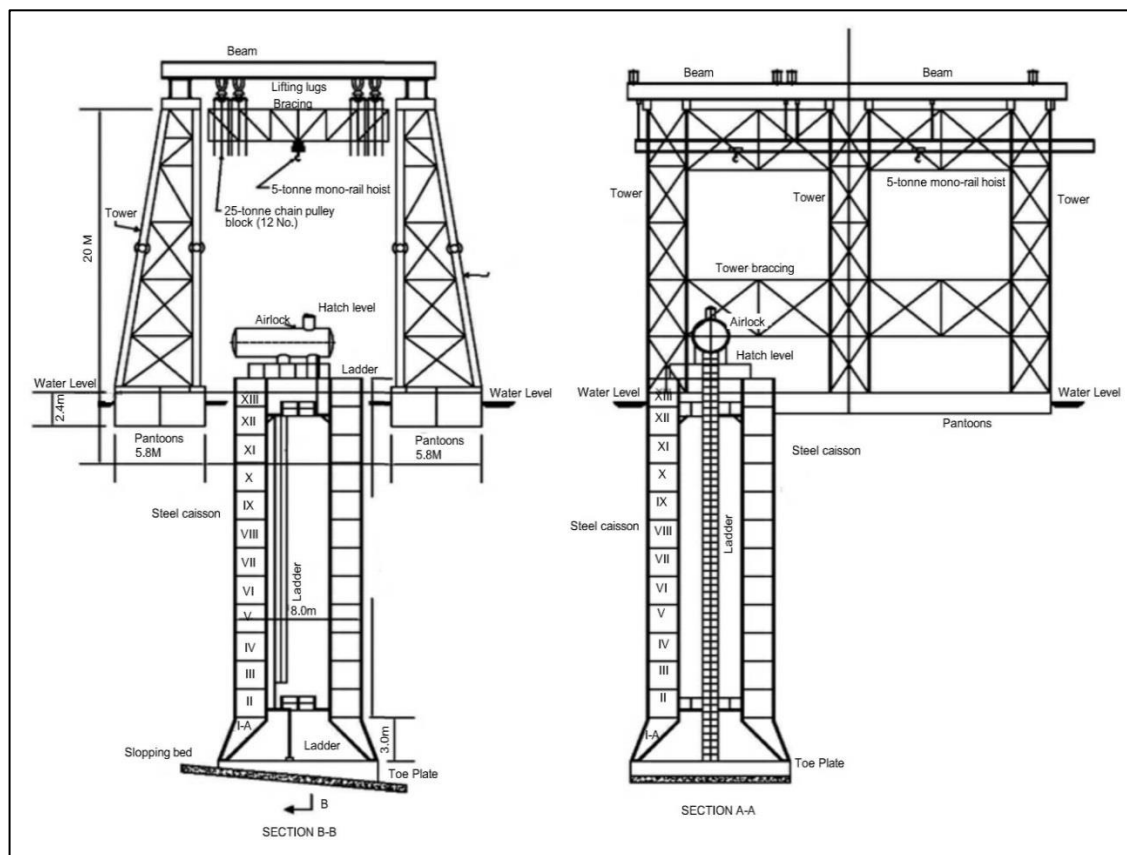

Figure 4 – General Arrangement of Pneumatic Caisson and Sinking Set

#### 7.3.2.2 Air Lock

It is a pressurised caisson vessel having three different compartments and is meant for entry of men and material to pressurized caisson for carrying out repair and is regulated through Air Lock. It has sufficient capacity to accommodate 10 persons at a time. The general arrangement of air lock is illustrated in Figure 5.

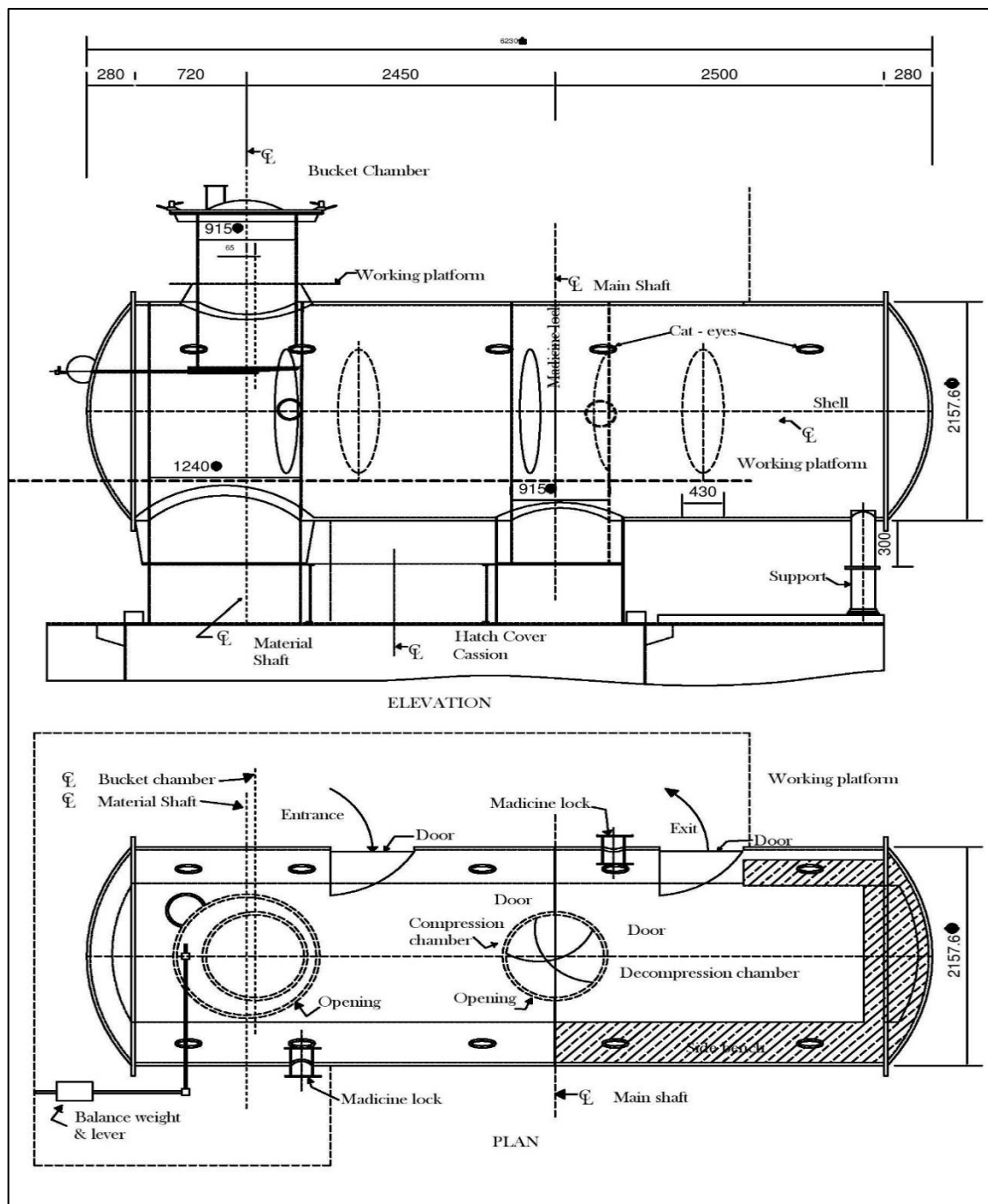

Figure 5 – General Arrangement of Air Lock

### 7.3.2.3 Sinking Set

Sinking set provides the necessary approach to the caisson besides handling the pneumatic caisson during assembly, subsequent maneuvering in each shifting and dismantling. It comprises of two pontoons of weight 60 tonne each having dimensions 26 m x 5.8 m x 2.4 m connected by struts and provided with gantry towers which support main and cross beams for carrying 12 numbers 25 tonne capacity chain pulley blocks for handling pneumatic caisson. Eight number crab winches provided on the sinking set for maneuvering of sinking set and pneumatic caisson. Two numbers monorail hoists move on monorail girder below bracing for job facilities during operation. Mixing of concrete is also done on the sinking set.



#### 7.3.2.4 Pneumatic Plant

The oil free compressed air meant to expel the water from inside the caisson was provided by two number electric driven non lubricated type air compressors on right side at EL.1225 ft. One compressor has 1440 cubic feet per minute (CFM) capacity and the second one has 750 CFM capacity. The supply of compressed air is provided by fixed pipe line which was in floating portion connected through metallic flexible pipe so as to take into consideration up and down variation of water level in the stilling basin. A separate diesel engine driven Air compressor of 500 CFM capacity was provided on the sinking set which serves as standby besides providing compressed air for drilling/chipping of concrete.

#### 7.3.2.5 Revolver Crane

For assembly and dismantling of sinking set, pneumatic caisson and other floating material, a revolver crane having 57 tonne capacity was used which was installed at EL.1225 ft on the left side.

#### 7.3.2.6 Electrical Equipment

Sinking set and pneumatic caisson had been well lighted by providing adequate number of high pressure mercury vapour lamps on the sinking set. Flame proof bulk head lights operated on 24 volts have been provided inside the pneumatic caisson. A 10 kilo watts diesel generator set has been provided as a standby in the event of failure of electric supply. Audio communication link was provided from inside the caisson to outside for proper co-ordination of work inside and outside.

#### 7.3.2.7 Operation of Caisson

After the caisson was stationed at the repair site, the water column inside the caisson was expelled by applying compressed air (maximum working pressure 2.5 kg/cm<sup>2</sup>) supplied from a non-lubricated type electric compressor. An approximate area of 9.2 m x 9.2 m was normally available for repair per setting of caisson. When the caisson was fully pressurized in the horizontal reach only a few centimeters of water was left at the bottom which was removed after putting the clay bag sealing. The surface was then prepared by removing all free water, drying of the surface to the extent possible, chipping of all loose, un-sound and improperly repaired previous concrete, roughening of the existing concrete surface to eliminate laitance and clean up to get rid of all loose material including much by air/water jetting and grease/oil stains by wire brushes. The area was divided into about 2 to 3 meters wide suitable strips parallel to the flow and repairs are carried out, starting from one end and continued in a manner so that bond is ensured between successive application of repair concrete. In order to ensure proper bond with the old concrete suitable epoxy formulation was applied to the prepared surface obtaining 1 mm to 2 mm thick bonding coat.

For repair in the sloping/curved portion of the spillway apron a toe plate matching with the profile of the apron was prepared and fitted at the bottom of the unit of the caisson to keep it in vertical position when grounded.

Depending upon the depth of erosion, the repair procedure has been divided into four categories as shown in Figure 6 and below;

- i) Erosion less than 75 mm deep.

The surface is treated by epoxy compound followed by epoxy concrete.

- ii) Erosion more than 75 mm and less than 200 mm deep.

The surface is treated by epoxy compound followed by concrete type C-2/CC-3 (4000 psi concrete with aggregate size 40/20 mm).

iii) Erosion more than 200 mm and less than 300 mm deep.

Involved fixing of 20 mm dia. anchors at 60 cm centre to centre spacing, surface painted with epoxy compound followed by concrete type C-2 (4000 psi concrete with aggregate size 40 mm).

iv) Erosion more than 300 mm deep.

Treatment was the same as per case iii above except that reinforcement wherever required, was restored.

The workmen were taken out after decompression in the de-compression chamber working maximum 4 hours inside the pressurised caisson and new group of maximum 10-12 persons was sent inside the caisson to carry out the remaining work.

Inspection/repair was being carried out regularly. For passing out excess water through spillway, the entire equipment in the stilling basin was taken out after dismantling, by 15th June and after the rainy season assembling of whole equipment was again started w.e.f. 16th October.

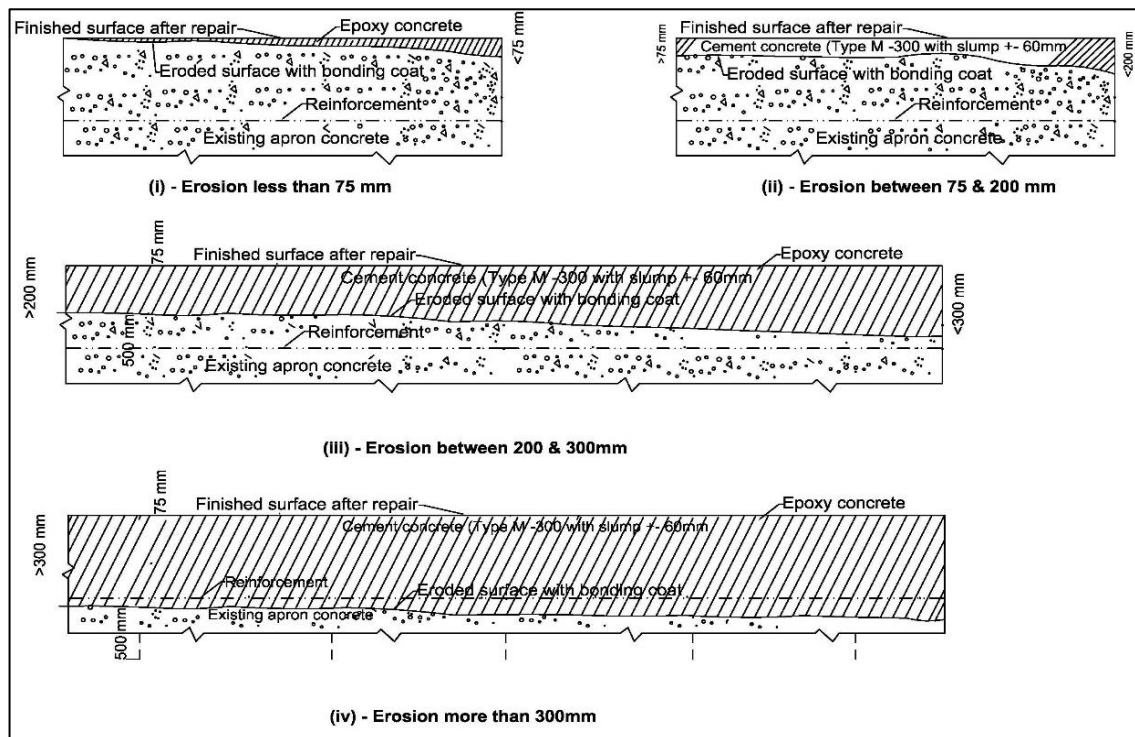

Figure 6 – Specifications for Apron Repair

## 7.4 Modifications Made With Experience

The modifications/improvements were carried out in air lock, air compressor, revolver crane, unit No. 1A and in sealing arrangement as detailed below;

### 7.4.1 Air Lock

Initially the air lock suitable for only 2-3 persons, was provided by the firm on hire basis. Persons are to be pressurised in groups for going inside the pneumatic caisson for working. These persons are being taken out without decompression and again pressurised and depressurised in the medical lock being placed on other site of work. The air lock provided by the firm was too small as compared to the magnitude of work. In order to meet requirements in the field, air lock was designed and fabricated departmentally in the

Nangal workshop alongwith de-compression chamber to accommodate about 10-12 persons required for each group of workmen for 4 hours, working inside the caisson.

#### 7.4.2 Air Compressor

For pressurising caisson, the firm supplied on hire basis non-lubricated type compressor powered by a steam engine. The coal fired compressor reduced the visibility inside the caisson. New non-lubricating type electrical compressors were purchased and installed, which improves the visibility inside the caisson. Thus, it became easy and safe to work under the improved conditions.

#### 7.4.3 Revolver Crane

Initially erection and dismantling of pneumatic caisson, sinking set and other equipment was carried out with the help of two cranes stationed on the ground level at EL.1225 ft which caused lot of problems for the safety of equipment and workmen. It took about two and a half months each for erection and dismantling process. After the completion of the Beas Satluj Link Project, a revolver crane having maximum capacity of 57 tonnes declared surplus by the Beas Construction Board was installed on the right side of top of the dam. The above said revolving crane was dismantled and erected at EL.1225 ft behind the left bank power house in 1985. This reduced erection/dismantling time of the whole equipment to less than one month.

#### 7.4.4 Unit No. 1 A

Initially the bottom unit having size of 8 m X 8 m X 2 m provides maximum 7.8 m X 7.8 m area inside the caisson in one setting. The bottom unit was modified to 9.5 m X 9.5 m X 3 m which provides maximum 9.2 m X 9.2 m area, which is approximately 1.4 times more area in one setting to be inspected/repared than the previous unit of 8 m X 8 m X 2 m.

#### 7.4.5 Sealing Arrangement

On entering the pressure caisson, it was found that water with depth up to 25-40 mm was standing on the damaged/eroded surface. The repair of the surface was carried out by dividing the entire area in 2x2 ft sub patches by placing gunny bags. Standing water inside the bags was removed by sponges. The surface area so dewatered was thoroughly washed and cleaned. This area was epoxy painted and repaired with epoxy concrete as the damage was accessed to be less than 3 inch. After the success of these trial patches, it was decided to modify the bottom unit so that water inside the caisson is expelled out and the whole area could be repaired in one lot. This was done by providing sealing arrangement inside the caisson as shown in Figure 7.

#### 7.5 Safety Precautions

Following Codal requirements for safely working in compressed air, as per Bureau of Indian Standard IS: 4138-1977 are fully complied with.

- i) Employment of experienced persons or new persons after suitable training and acclimatization.
- ii) Medical supervision and certifications of the persons entering the compressed air.
- iii) Provision of Medical lock for treatment of persons. Supply of hot Drinks-Tea, Milk or Coffee was supplied free of cost.
- v) Carrying of inflammable articles inside the air lock was strictly prohibited.
- vi) Persons under the influence of alcohol or suffering from cold, sore throat, ear-ache or other ailment, were not allowed entry in the air lock.

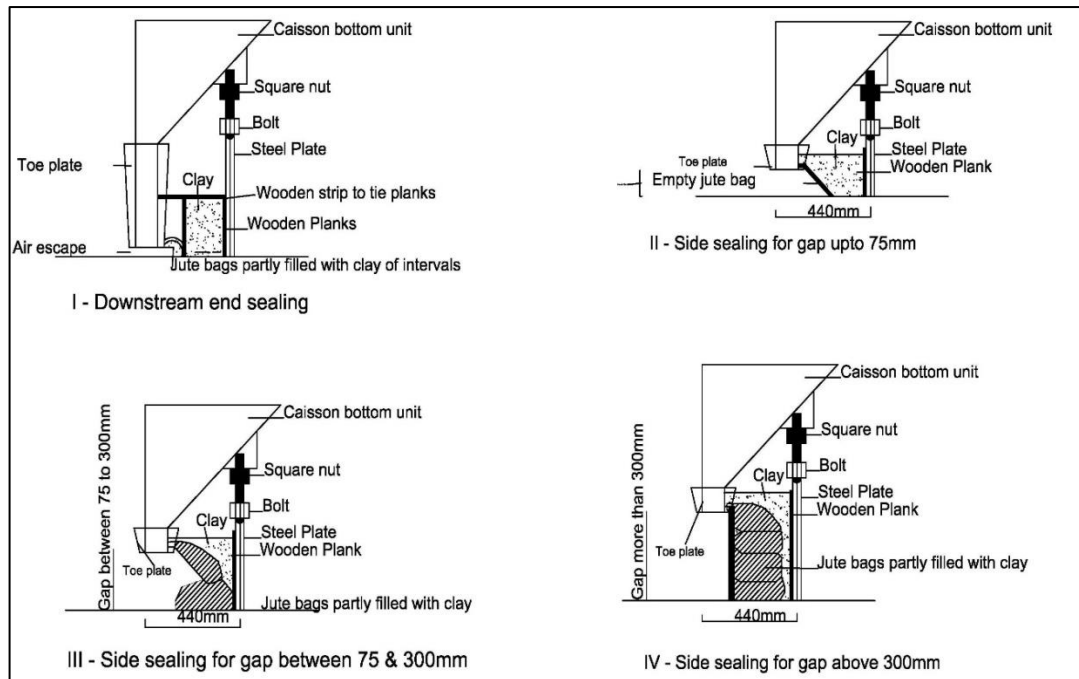

Figure 7 – Sealing Arrangement at Bed Level

- vii) Hours of working were strictly in accordance with the codal requirements.
- viii) Temperature in working chamber – Air was water cooled and provision of spray nozzles on the air lock (compression on and decompression chambers) were made.
- ix) Provision of oil free compressed air and in required quantity.
- x) Provision of stand – by compressor.
- xi) Sufficiency of size of compression and decompression chambers.
- xii) Ban on the entry of electric tools in the compressed air zone.
- xiii) Provision of accurate pressure gauge as well as wet and dry bulb thermometers.
- xiv) Emergency light circuit operated by battery.
- xv) Testing of equipment etc.

## 7.6 Conclusions

In the peculiar conditions prevailing at Bhakra Dam, where spillway stilling basin is located in between two major Hydro Electric Plants, the repair by Pneumatic Caisson Method is the best possible solution to have uninterrupted Irrigation and Power generation.

Repair is being carried out in dry conditions with this technique, which is as perfect as could be achieved by dewatering the spillway apron area leaving only certain inaccessible spots which are hardly a fraction of the total eroded surface.

During inspections, it has been observed that the repair carried out to spillway apron by Pneumatic Caisson Method withstand very well inspite of passing heavy discharges through spillway. Thus, this method of underwater repair of concrete has been found quite successful and reliable.

This page has been left blank intentionally.

## 8. SARDAR SAROVAR DAM

### 8.1 Preamble:

Narmada, the fifth largest river of the Indian peninsula, is the largest west-flowing river of the country. It rises in Amarkantak plateau (altitude of about 900 m) in the scenic settings of Maikela hills of Satpura range in Shahdol district of Madhya Pradesh. Traversing a distance of 1312 km in a generally westerly direction through Madhya Pradesh, Maharashtra and Gujarat states, the river debouches in to the gulf of Khambat of the Arabian Sea, a little beyond Bharuch in Gujarat. Total catchment area of Narmada Basin is 98,796 km<sup>2</sup>. There are about 32 major project and number of medium and minor project envisaged for development of the Narmada Basin in Madhya Pradesh and Gujarat.

Sardar Sarovar Project is the interstate terminal project of Narmada Basin with a total catchment area of 88,000 km<sup>2</sup>. The gross storage capacity of Sardar Sarovar Dam is 9460 McM (7.7 MAF). It is a concrete gravity dam with FRL at EL 138.68 m and total length of dam is 1210 m. The dam is having 64 blocks out of which 30 blocks are spillway blocks. Out of 30 spans of the spillway, 23 spans are of service spillway and remaining 7 are auxiliary spillway. Service spillway of 23 blocks are having stilling basin which is again divided in 5 bays, 9 panel each having total area of 1, 12,875 sq.mt and average depth of 4.5 m. There are 30 radial gates out each 23 are service gate and 7 gates are provided in auxiliary spillway. Each gate is having discharge capacity of 1 lakh cusec at FRL. It has two power houses namely RBPH having 6 units of 200 MW and CHPH having 5 units of 50 MW. Total installed capacity of both power houses is 1250 MW.



Upstream view of Sardar Sarovar Dam Spillway





Downstream view showing the spillway

A view showing the main dam, spillway, stilling basin (bays 1 to 5) & plan of the entire stilling basin given below.



**VIEW SHOWING STILLING BASIN - BAYS NO.1 TO 5**

## PLAN SHOWING STILLING BASIN

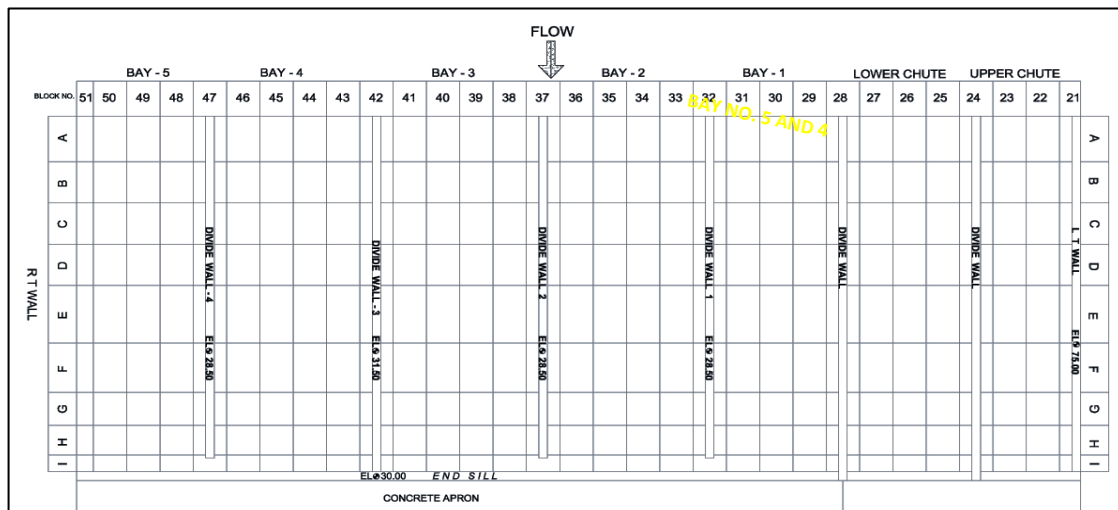

## 8.2 Stilling Basin Design criteria:

The structural design of the stilling basin apron was based on the latest state-of-the-art, with the consideration of the Macro Turbulence effects on the lining of stilling basin. The structural design of the stilling basin was based on the paper published in the 13<sup>th</sup> ICOLD “EXPERIMENTAL ANALYSIS OF MACRO TURBULANCES ON THE LINING OF STILLING BASINS BY JOSE.L.SANCHEZ BRIBIESCA et. Also the conventional procedure has been adopted for designing of apron based on hydrostatic forces and other considerations specified in the relevant Indian Standard codes of practice.

While designing the stilling basin, CWPRS, Pune and their consultant of international reputation was involved and same has been reviewed by various meeting of Dam Design Review Panel (DDRP) and Dam Safety Panel (DSP) from time to time. The broad features of the design are; 6.0 m concrete thickness slab at the beginning (i.e. at toe of dam) tapering down to 3.5 m at the end of horizontal portion (near end sill) at EL 12 m and recovery slope with End Sill at EL 30.0 m. Thus, Maximum depth of water in Stilling Basin is 18 m. The apron was also provided with elaborate peripheral drainage galleries partly in concrete and partly in rock and grid of half round pipes to reduce the effects of hydro dynamic forces resulting in uplift pressure. The anchor bars are also provided to withstand uplift pressure.

## 8.3 What is Macro turbulence?

In late 70 and early 80, lot of research were done by different research engineer all over the world to find out the damages that was observed in stilling basin of the dam located at difference places.

Numerous authors studied the hydraulic jump, after the earlier experiments of Leonardo Da Vinci and the classic publications of Bidone and Bu’langer. Then, it was possible to obtain mathematically the basic parameters of the jump, by the only considerations of the mean flow in time, for example sequent depths, energy transformation and jump lengths, released with the incident Froude Number.

The jump is used for different purposes: as energy dissipater, as aeration system for water supply and to mix chemical products, but the former is the most important for hydraulic engineering. The hydraulic jump is caused by the internal flow in the jump and this is essentially unsteady.

A hydraulic jump can be considered macroscopically as a steady, abruptly varied flow, characterized by a free surface discontinuity and the formation of a strong vortex which generates macro turbulent fluctuations, air entrainment and kinetic energy dissipation.

As it is known, turbulence is not a physical property of the fluids. It is a property associated with the flow, and it has five characteristics: random nature, rational flow, nonlinear behaviors; diffusion and dissipation. Authors explain the turbulent flow as a transport of vortex with different sizes by the mean flow. Big vortex is associated with low fluctuation frequencies. It is generated by boundary conditions and its size is on the same order of magnitude than the flow dominion. They interact with the mean flow, releasing kinetic energy and feeding the macro turbulent fluctuations.

Big vortex originates other smaller vortex, and so on, and the energy transfer is produced as an “energy cascade”, until the smallest vortex, where the viscous forces act and dissipate mechanical energy in heat. Then, the proportion of the mean flow energy converted as fluctuations is only fixed by the macro turbulence. Viscosity is not relevant in connection with kinetic energy dissipation in to the jump, but it indicates the scale of vortex where dissipation is really accomplished.

Hydraulic jump energy dissipation is always associated with severe pressure fluctuations, acting on the floor of stilling basins, downstream of spillway piers and on any appurtenance included for forced energy dissipation. The fluctuating action may cause vibrations, lift forces, fatigue of materials and large instantaneous depressions which could produce intermittent cavitations inception. Macro turbulent fluctuations are amplified by discontinuities in the flow boundary, which increase the spatial correlation and facilitate the energy concentration around a dominant or peak frequency. Then, the problems are more dangerous when the energy dissipater has sharp-edges structures or appurtenances.

In 1979 Jose L Sanchez Bribiesca has published paper on “*Experimental Analysis of macro turbulence effects on the lining of stilling basins*”, where how effect of macro turbulence has been taken in to account in design of stilling basin is given.

#### 8.4 History of damages and repair of stilling basin:

Sardar Sarovar Dam has been constructed in stages from the year 1994 onwards. Up to year 1994, different blocks were at different level. But after observing huge damages in the year 1994 (due flood events of different magnitude from 3 lakh cusec to 25 lakh cusec flood), it has been decided to keep all spillway blocks at same level. As ogee shape was not reached (full ogee shape is at EL 121.92 m), it was behaving like broad crested weir. Therefore concept of hump was also introduced afterward. This has helped spillway blocks to work as ogee shape for flood up to 10 lakh cusec. The dam height was at EL. 85.00 m. in the year 2000 and reached to El.121.92 m. in December 2006 in stages and further construction of piers up to its full height was withheld at El. 121.92 m. up to the year 2014. During this period, it has undergone many floods. As the spillway ogee shape was not completed, remarkable damages were observed in the stilling basin. Stilling bay No. 1, 2 & 3 were repaired in the year 2007 as per the recommendation of DSP in its 46<sup>th</sup> meeting. DSP has also recommended to have underwater photography of stilling basin every two / three year interval, to know the extent of damage. Then in the year 2014, stilling basin bay No. 4 & 5 are repaired after the report of National Institute of Oceanography (NIO) who has conducted under water videography and reported the extent of damages in the stilling basin. As significant period has passed after repair, and the dam has been completed, stilling basin bay No. 1, 2 & 3 have been repaired in the year 2016 after dewatering. The methodology for repairing of stilling basin has been elaborated in following paragraphs.



8.5 Type and extent of damages:

The type and extent of damages has been reduced over a period of time after achieving ogee shape in the year 2006 (December). Earlier in 1994 and onward when ogee shape was not reached damages observed were much more. The photographs of damages observed in different years are given below:

**PHOTO OF DAMAGES**

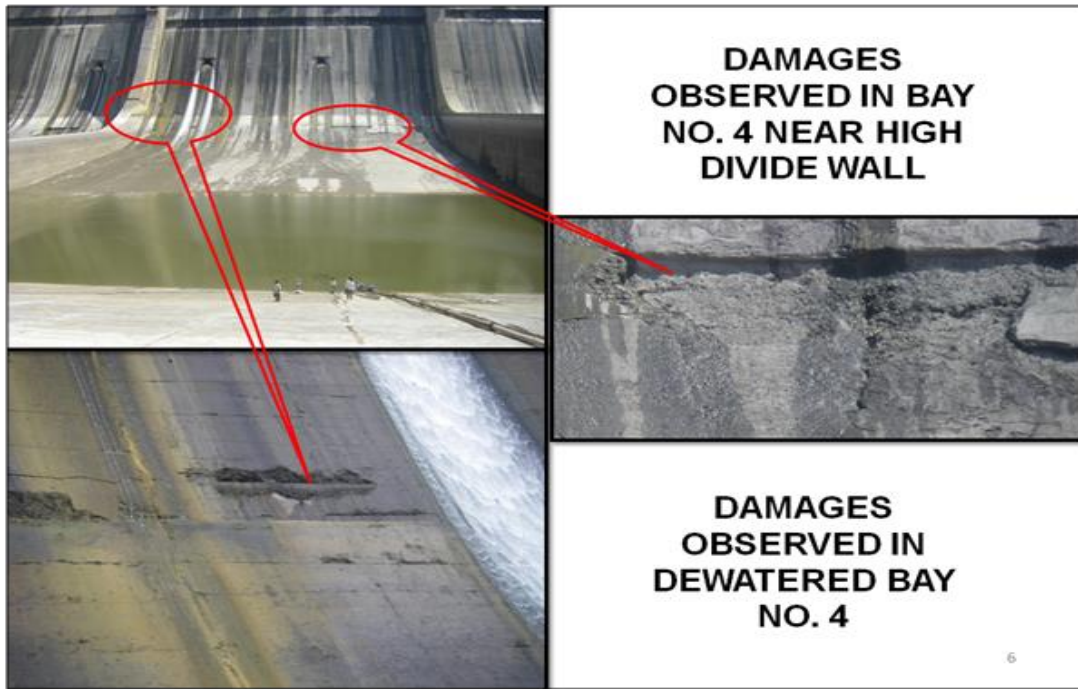

Damages observed in dewatering bay No. 5

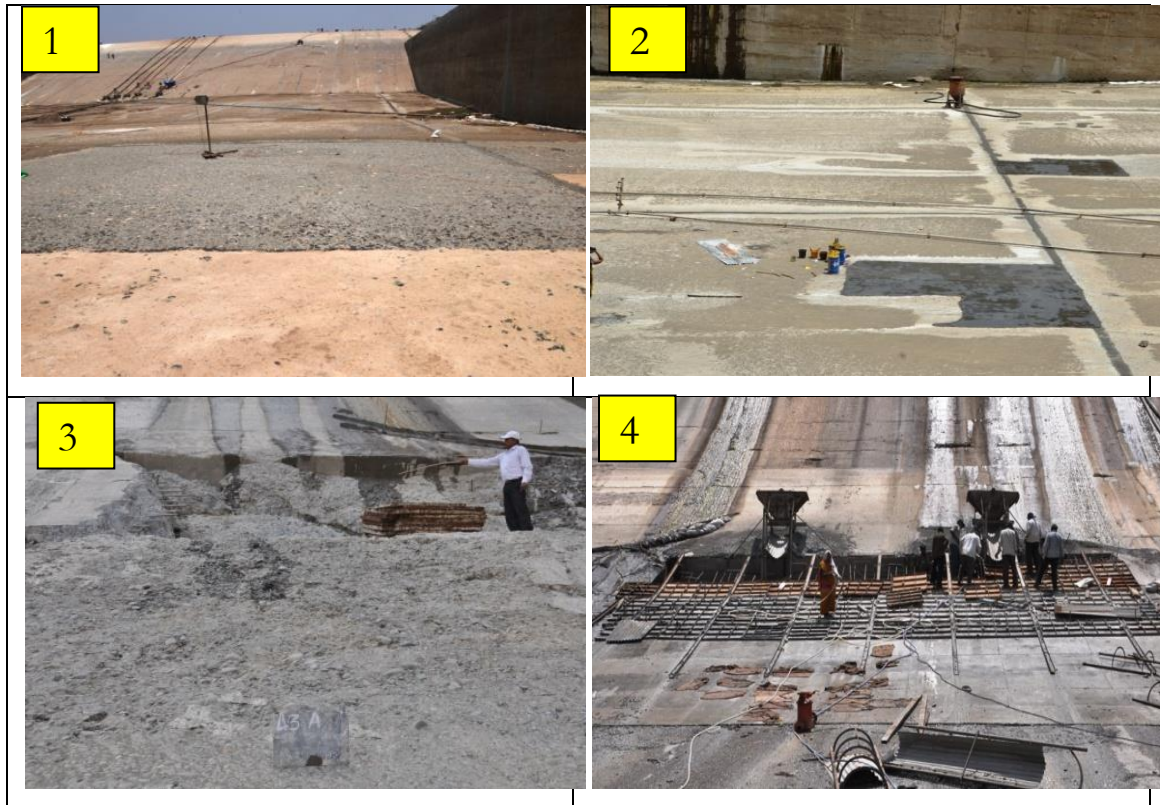

Methodology used for repairing of Stilling Basin

Repairing works of patches observed were classified in four categories:

1. Repairing of damage in joints and erosion on top surface
2. Repairing of damage area/patch less than 20 cm depths
3. Repairing for area/patch above 20 cm damage
4. Repairing of top 1.0 m depth damaged concrete

(A) Damage in joints and erosion on top surface

- Identify the area to be repaired and mark the same
- Removal of all loosed unsound material, algae or other foreign particles by wire brush, air & water jet at pressure 4 to 4.5 Kg/cm<sup>2</sup>
- Apply a bond coat of Dobeckot - 505 C + Hardener EH-411 mixed in the ratio of 100:50 proportion by weight (pbw)
- After bond coat, apply wearing finish course in two layers
- First layer 10 to 12 mm thickness of Dobeckot-5022 + Hardener EH-408 + Silica filler (M10 size) in 100:50:800 pbw ratio
- Second layer 10 to 12 mm of thickness of Dobeckot - 5022 + Hardener EH-408 + Carborandum filler (M10 size) + Silica filler (M10 size) 100:50:400:400 pbw ratio i.e. total thickness of 25 mm.
- The patch shall be backfilled in two layers of 10-12 mm each



- Apply a seal coat of Dobeckot - 505 C + Hardener EH-411 mixed in the ratio of 100:50 pbw.

EPOXY TREATMENT IN JOINTS



REPAIRS OF JOINTS



BLOCK 49 – PANEL C – AFTER EPOXY FINISH



## (B) Damage area/patch less than 20 cm depths

- Identify the area to be repaired and mark the same
- Removal of all loosed unsound material, algae or other foreign particles by wire brush, air & water jet at pressure 4 to 4.5 kg/cm<sup>2</sup>
- Make square edge of the patch / pot hole
- Make the patch in possible regular shape
- Apply a bond coat of Dobeckot – 505-C + Hardener EH-411 mixed in the ratio of 100:50 by weight
- Pour A20-S310-CL450 grade self-compacting concrete 25 mm below the design profile
- Cure the concrete for 15 days

Bay: BL 44 – Panel C – Patch before Treatment



Bay-4 : BL. 44 – Panel-C – After Pouring Concrete





## (C) Damage area/patch more than 20 cm depths

- Identify the area to be repaired and mark the same
- Removal of all loosed unsound material, algae or other foreign particles by wire brush, air & water jet at pressure 4 to 4.5 Kg/cm<sup>2</sup>
- Make square edge of the patch/pot hole
- Make the patch in possible regular shape
- Provide 25 mm dia. dowel wherever required (2 m in rock & 2 m c/c)
- Providing and fixing temperature reinforcement 16 mm dia. 30 cm c/c both way wherever required
- Apply a bond coat of Dobeckot - 505 C + Hardener EH-411 mixed in the ratio of 100:50 pbw
- Pour A20 S310 CL450 grade self-compacting concrete 25 mm below the design profile
- Cure the concrete for 15 days

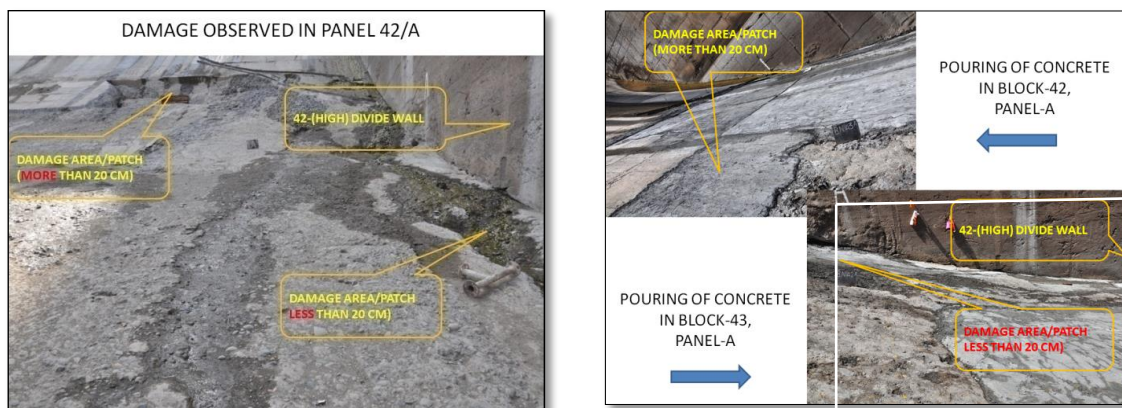

## (D) Top 1.0 m Depth Damaged Concrete

- Removing loose concrete material
- Repairing of sheared off anchors
- Fixing of dowels of 25 mm dia. 2 m in old concrete at 2 m c/c
- Providing and fixing temperature reinforcement 16 mm dia. 30 cm c/c both way
- Pouring of control concrete A 40 S350 CL 450 up to design profile

A – Maximum aggregate size (mm)

B – Cylinder strength after 28 days (kg/cm<sup>2</sup>)

CL – Cement level (kg/m<sup>3</sup>)



Night view of Sardar Sarovar Dam

This page has been left blank intentionally.

## 9. PARBATI DAM

### 9.1 Brief Description of the Project

Parbati irrigation Project is located across river Parbati, which is a tributary of river Chambal, near Angai village in Basen tehsil of Dholpur district, Rajasthan. The construction of the dam and canal system was completed by the Rajasthan Irrigation Department in the year 1962-63 at a cost of about Rs. 162 lakhs. The project is about 50 km from Dholpur and is approachable from Dholpur-Karauh state highway. It was designed to irrigate 30,477 acres (12,334 hectares) of land.

The project consists of a composite dam with a total length of 6.95 km (228 chains). There is a homogeneous earthen dam from ch. 0.0 to ch. 174.50 in the right bank, a masonry N.O.F. dam from ch 174.50 to ch 187.0 in the deepest river portion and a masonry spillway from ch. 187.0 to ch. 228.0 in the left bank (1 chain = 30 m). A d/s view of the spillway and an indicative layout sketch of the masonry dam are at Figure 1 & 2. The salient features of the project are at Annexure-1. The masonry N.O.F. dam has two under sluices of size 1.2 m x 2.13 m each at ch. 180.0. The spillway is ungated for most of the length. It was designed for a flood of 62,560 cusecs (1772 cumec) with a maximum flood lift of 0.91 m. In a short reach between ch. 219.50 and ch. 220.90 the spillway is gated (11 gates of size 3.04 m x 2.4 m each). Four canal sluices of the size 1.2 m x 2.13 m each were provided at ch 203.50. However, no energy dissipation arrangements were provided in the spillway.

In addition there is a masonry bye wash between ch. 228.0 to ch. 232.0 which was added subsequently and a masonry saddle dam between ch. 238.0 to ch. 272.0. A foundation gallery was provided in part of the masonry dam from ch. 176.0 to ch. 198.0 at a relatively high level with access from four adits - three being in the N.O.F. portion and one in the O.F. portion which was projecting in the downstream. The masonry dam was constructed with lime mortar as a single monolith without any contraction joints and without any proper geological appraisal at that time



Figure 1 – Downstream view of Spillway



## 9.2 Problems Encountered after construction of the Project

The project was commissioned in 1963. Since its commissioning, a number of problems have been encountered. Some of the important ones are listed below:

- 9.2.1 The masonry dam which is about 490 m long was constructed in lime mortar without any contraction joints. As a result of that twelve cracks were observed in the year 1971. The number increased to 32 in 1981. These cracks were in random directions but mostly vertical at about 30 m intervals extending from top to bottom and visible from both the u/s and d/s faces of the dam and in the foundation gallery. However no discernible differential movement was observed along the cracks. Most of the cracks which occurred were in the reach between ch. 175.0 and ch. 213.0.
- 9.2.2 There had been excessive leakage/seepage in the masonry dam right from the very beginning. This was observed in various locations like foundation gallery, through cracks in the dam and at the d/s face of the dam at selected points. The seepage was in all forms like sweating, oozing, trickling, sprouting like fountains, flowing conditions etc. Inadequate quality control during construction, cracks in the dam body and the horizontal lift joints were the major causes of excessive seepage through the dam and leaching of lime mortar. Leakage was also seen through the open bedding joints in the foundations.
- 9.2.3 No energy dissipation arrangements were provided below the spillway. This resulted in a lot of scouring in the d/s area. A lot of blocks of foundation rock (sand stones) were seen dislodged. Moreover erosion just d/s of the spillway was detrimental from the stability point of view also.
- 9.2.4 The spillway was designed for a flood of 1772 cumec. Subsequently greater floods passed over the spillway.

Some such instances are listed below:

Year 1972	3548 cumec (125275 cusec)
Year 1975	1987.9 cumec (70179 cusec)
Year 1995 (Sept.)	3787.9 cumec (133714 cusec)

This necessitated a review of the safety of the dam from hydrological considerations.

- 9.2.5 Damages to canal were common due to the layout of spillway provided-necessitating substantial remodelling/maintenance works.
- 9.2.6 On account of lack of maintenance, the d/s face of the earth dam suffered a lot of erosion/disfiguration due to ram-cuts etc.
- 9.3 The matter was referred by the Rajasthan Irrigation Department to CWC for suggesting remedial measures in 1983. The following studies/works were considered at that time :
- i) Review of the design flood of the project in light of additional hydrological data available.
  - ii) Geological appraisal of the dam foundations.
  - iii) Hydraulic model studies with a view to finalise the modifications in spillway profile and the energy dissipation arrangements for the revised design flood.
  - iv) Gunting/addition of concrete lamina on the u/s face of the masonry dam with contraction joints at the location of cracks and proper sealing arrangements for controlling seepage.

- v) Raising of the top of NOF masonry dam and earth dam for the revised MWL.
  - vi) Materials testing for evaluation of an average value of the density of the existing masonry,
    - a. compressive strength of lime mortar etc.
  - vii) Provision of energy dissipation arrangements and modifications in the spillway profile for the revised flood.
  - viii) Monitoring of the cracks by providing glass tell-tales etc.
  - ix) Monitoring of uplift and improvement in drainage facilities.
  - x) Preparation of monthly/bimonthly reports on chemical examination of water in reservoir.
  - xi) Periodic monitoring of seepage through the masonry dam.
- 9.4 The GSI team carried out geological appraisal of the site in the field season 1984-85. The investigations revealed that the foundation rock consists of horizontal to low dipping upper Vindhyan sandstones. The sandstones which are bedded in nature are exposed in the overflow section. However towards the earthen dam there are no exposures of rock. The sandstones are also intersected by transverse joints. Bedding joints are also prominent. Sub-surface explorations further indicated presence of clay/weathered/ sheared sandstone seams in the foundations at shallow depths.
- 9.5 Subsequently the work of rehabilitation of Parbati dam was included under the Dam Safety Assurance and Rehabilitation Project with World Bank Assistance. A Dam Safety Review Panel (DSRP) was appointed by the Government of Rajasthan as per conditions of the World Bank. CWC was requested to provide complete consultancy for rehabilitation of the project in September, 1991.
- 9.5.1 Considering the critical state of the dam, trial grouting in the body of masonry dam was suggested in consultation with the DSRP initially along one row' at 1 metre d/s of the dam axis. Before taking up grouting work, the leaks on the u/s face were sealed by pointing to enable grouting to be effective. Grouting operations were first carried out in the masonry NOF portion and then in the spillway portion. Descending stage grouting at stages of about 6 m was adopted. Percussion drilling was done with drifters. The spacing of the holes was initially kept as 6.0 m c/c which was further reduced to 3.0 m c/c and then to 1.5 m c/c based on post grout permeability results. For stages showing heavy water loss, sand was proposed to be added for grouting. Use of admixtures/chemicals was also recommended, where necessary. As a result of this grouting, seepage on the d/s face of the dam and in the gallery reduced considerably. On account of the encouraging results, it was decided to carry out one more row of grouting slightly d/s of the first row (1.75 m from dam axis) and two rows of curtain grouting of the foundation rock from the foundation gallery followed by drainage holes in the body of the dam and in the foundations by drilling holes from the gallery/top of dam.
- 9.5.2 The density of the masonry was tested at various locations. It was seen that the average density was low ( $2.09 \text{ t/m}^3$ ) probably on account of profuse seepage through the dam. However DSRP was of the view that grouting of masonry will only help in marginal improvement of density by filling the voids in masonry where the mortar had been washed away. As per the DSRP the cement grouting cannot be expected to improve the lime mortar masonry since cement will not be able to penetrate into the voids in mortar. At one point of time it was planned to also carry out grouting of the dam by one/more rows from the d/s face of the dam to improve the density of masonry.

However this idea was given up on account of the above apprehensions expressed by



the DSRP. It was also felt by DSRP that grouting of the d/s region of the sections may block natural seepage resulting in building up of uplift pressures.

- 9.5.3 Tests were conducted to assess the compressive strength of the existing lime mortar masonry. Point load tests were performed by CSMRS/GERI and an attempt was made to evaluate the cube strength of the mortar by suitably correlating the tested values to the cube strength. The values of compressive strength of masonry arrived at by these tests were found to be extremely low (about 12.95 kg/cm<sup>2</sup>). Uncertainty existed about these values on account of limitations like very small size of samples of mortar taken from the dam, their shape etc.
- 9.5.4 The DSRP was not initially supportive of the CWC proposal of providing an u/s concrete lamina for controlling seepage on account of factors such as :
- i) Apprehensions regarding proper joining/bonding of new concrete to the existing masonry.
  - ii) Apprehensions regarding design of anchors between masonry and u/s concrete lamina in view of difficulties in accurate assessment of interface stresses and stress concentrations around anchor rods. Besides provision of u/s concrete lamina involved dewatering of the reservoir and loss of irrigation benefits for at least one season.
- 9.5.5 Based on review studies earned out by the Hydrology Unit of CWC, a PMF of 7150 cumec was recommended for the project. The design flood considered earlier by the RID while constructing the dam was only 1772 cumec, the FRL being (223.114 m) 732.0' and the MWL (224.028 m) 735.0'. Flood routing studies were earned out for the following alternatives with the revised flood :

**Alternative 1** - With existing spillway arrangements, *i.e.* :

- i) Uncontrolled spillway with crest El. 233 m from ch. 187.0 to 203.0, 204.5 to 219.5 and 220.9 to 228.0.
- ii) Gated spillway with crest El. 220.7 m and having 11 gates of size 3.04 x 2.74 m each.
- iii) Bye-wash with crest/floor level at El. 223 m from ch.228 to 232.0 (121.9 m long).

**Alternative 2** - Same as Alternative - 1 but with an additional 182.9 m length of bye wash.

**Alternative 3** - Same as Alternative - 1 but with existing gated spillway converted to an ungated spillway with crest at El. 233 m.

**Alternative 4** - Same as Alternative - 1 but with existing gated spillway converted into NOF block.

MWL (metre)	Peak rate of outflow (cumec)	
Alternative - 1	225.10	6673
Alternative - 2	224.90	6712
Alternative - 3	225.14	6674
Alternative - 4	225.18	6657

Alternative - 1 (existing spillway arrangements) was preferred. It was felt that an auxiliary spillway was not necessary as the difference in MWL was very small, *i.e.*, only 20 cm.

Thereafter freeboard calculations for masonry NOF blocks, saddle dam and earth dam were carried out and the revised dam top levels calculated. A flip bucket arrangement for

energy dissipation along with a d/s concrete apron was designed below the spillway from ch. 187.0 to 197.0.

- 9.5.6 The NOF and spillway sections of the masonry dam (as constructed earlier) are at Figure 3 & 4. The results of the stability analysis are at Annexure - 2. It was seen that tensile stresses exist in load combinations C,D,E,F and G. In view of the doubts regarding compressive strength of mortar/masonry and heavy seepage through the dam, the DSRP was of the view that the codal provisions of BIS-6512 should be conservatively interpreted and that no tension be allowed in condition 'C' (Reservoir at MWL and normal uplift). For other conditions like 'E' (Reservoir at FRL, normal uplift and earthquake), 'F' (Reservoir at MWL but with drains choked) and 'G' (condition 'E' but with drains choked), the DSRP was of the opinion that some tension as per BIS-6512 based on the actual compressive strength of the masonry/mortar could be allowed *he*. taking compressive strength of masonry as the maximum compressive stress withstood by the dam so far with a reasonable uplift distribution and with a safety factor as unity).

Proposals for strengthening of the masonry dam were worked out by adding a continuous concrete lamina on the d/s face. In the calculations carried out, the reservoir bonding level was taken as the MDDL i.e. El 213.65 m. The existing section was assumed to take the following loads:

- i) It's self-weight.
- ii) Water pressure upto El 213.65 m (bonding level) and corresponding uplift.
- iii) Silt pressure with silt level of El 212.65 m.

The additional loads like self-weight due to d/s lamina addition and heightening of the dam, earthquake forces, additional uplift etc. were assumed to be taken by the full section (*i.e.*, by the existing section strengthened with d/s concrete lamina addition).

## 9.6 Flood Damages in September, 1995

The project experienced a major flood in September, 1995. Heavy rainfall occurred in the catchment area of the dam in the night of 3<sup>rd</sup>/4<sup>th</sup> September, 1995 resulting in flash flood in the reservoir on 4<sup>th</sup> September, 1995. The inflow which was only 446.34 cumec (15,762 cusecs) at 8 a.m. on 4.9.95 shot up to 4621.72 cumec (1,63,216.12 cusecs) at 9 a.m. on 4.9.95. The reservoir reached a level of 223 m at 9 a.m. and 224 m at 2 p.m. on 4.9.95. The maximum outflow from the reservoir was 1,33,714.19 cusecs (3786.33 cumec) at 4 p.m. on 4.9.95. The spillway of Parbati dam was originally designed for an outflow of 1771.49 cumec (62,560 cusecs). Thereafter an additional capacity of 164.80 cumec (5820 cusecs) was added through the by wash constructed between ch. 228 to ch. 232. Thus the total discharging capacity of the spillway available at site was only 1936.29 cumec (68,380 cusecs) against which 3786.33 cumec (1,33,714.19 cusecs) passed *he*, 196% of the available capacity).

After the flood receded the masonry portion of the dam was inspected by the project authorities on 5.9.95. Pot holes between ch. 196.3 and ch. 197.20 along with heavy seepage/leakage were observed. In addition the gallery adit no. 4 at ch. 197.0 m the spillway portion cracked resulting in heavy seepage from the damaged portion between ch. 196 to ch. 197.50.

Further the spillway crest and d/s toe masonry was damaged at a number of places. The divide wall at ch.201 and concrete apron between ch. 198.5 to 199.0 was also completely damaged by the flood.

9.6.1 The probable causes of damages could be :

- i) Passage of a discharge of 3789.9 cumec (1,33,714.19 cusecs) over the spillway as against the spillway capacity of only 1937 cumec (68,380 cusecs).
- ii) The offset/projection of adit no. 4 on the d/s face of the spillway could have resulted in cavitation damages near it by way of pot holes, cracking of the adit.
- iii) Erosion of d/s rock and toe masonry could have been due to inadequate energy dissipation arrangements in the dam.

9.6.2 Only one row of grouting at 1m d/s of the dam axis had been carried out before the flood. In view of the possible danger to the safety of the dam on account of the damages caused, the reservoir was depleted by the project authorities and a toe support was provided by boulders/crates in wire mesh to the damaged portion initially. The depletion of the reservoir also enabled the project authorities to carry out the appropriate treatment at the d/s face of the masonry dam.

9.7 Rehabilitation Measures Proposed

Subsequent to the damages suffered by the dam in the September, 1995 flood, the rehabilitation measures proposed earlier were reviewed. The following actions were proposed

- i) 1.5 m thick concrete lamina on the u/s face of the masonry dam with joints at regular intervals and seals.
- ii) Two rows of grouting of the masonry dam from the top at a distance of 1.0 m and 1.75 m from the dam axis. The first row of grouting had already been carried out earlier.
- iii) Two rows of curtain grouting of the foundation rock from the foundation gallery in the masonry dam at an inclination of  $5^{\circ}$  to  $10^{\circ}$  to the vertical upto a depth where the water loss values were less than 5 lugeon.
- iv) Drainage holes d/s of the grout holes from the foundation gallery of the masonry dam both in the dam body and also in the foundations.
- v) Conversion of part of ungated spillway in the reach between masonry NOF and canal sluices into a gated spillway with details as under :
  - a. Gated spillway with 18 gates of 10 m x 4 m each and 18 piers of 3 m width each in the reach from ch 188.17 to ch. 195.75 with crest level at El 219.115 m.
  - b. Construction of a new concrete gated spillway with 4 gates of 10 m x 7 m each and 5 piers of 3.5 m width each in the reach from ch. 195.75 to ch. 197.52 with crest level at El 216.115 m in the damaged reach by dismantling the existing damaged masonry totally.
- vi) Construction of a new concrete masonry NOF section between ch. 197.52 and ch. 198.03 m in the damaged reach by dismantling the existing damaged masonry totally. The foundation gallery was continued in the new spillway and NOF blocks. The basic idea of providing the NOF block was to provide access to the foundation gallery from the top of dam through a stair wall.
- vii) A sump well and pump chamber in the new concrete O.F. block
- viii) Raising of the remaining ungated portion from El 223.114 m to El 223.50 m so that it comes into operation for high floods only and is not used for discharging floods normally experienced.
- ix) Strengthening of the masonry NOF and spillway sections by addition of a d/s con-

crete lamina from stability considerations. No tension was allowed in any condition. The u/s concrete lamina was not considered in the stability calculations as per the recommendations of the DSRP. The modified sections proposed are at Figure 5, 6(a), 6(b) & 7.

- x) Energy Dissipation arrangements by way of flip bucket below the O.F. section.
  - xi) Remodelling of the canal structures by :
    - provision of stilling basin d/s of the canal sluices
    - provision of suitable cross drainage work for the drainages encountered by the canal in the d/s region of the dam.
  - xii) Provision of energy dissipation arrangements d/s of the under sluices.
  - xiii) Suitable remodelling of the earth dam section and heightening to provide for free board over the revised MWL.
  - xiv) Provision of 5 m wide road bridge over the gated spillway and a foot bridge over the remaining ungated spillway upto the canal sluices
- 9.8 The revised MWL obtained was El 224.0 m, the FRL being El 223.114 m. The ungated spillway has a higher crest level of 223.50 m and would come into operation only in rare instances. The discharging capacity of the gated spillways at El 223.50 was about 5500 cumec (1,94,227 cusecs).
- 9.9 For addition of u/s concrete lamina to impart imperviousness the following course of action was suggested :
- i) Raking of joints to a depth of at least 50 mm.
  - ii) Cleaning of the masonry surface thoroughly by sand blasting.
  - iii) Drilling and insertion of grouted anchors on the u/s face of masonry.
  - iv) Application of epoxy adhesive to the masonry surface of approved quality/brand.
  - v) Addition of u/s concrete lamina in layers using suitable water reducing agents for reducing shrinkage in concrete.
- 9.10 For addition of d/s lamina in the NOF and gated spillway sections, it was proposed to dismantle the d/s masonry in steps and to add the concrete lamina in layers with transverse contraction joints following the same procedure as outlined for addition of the u/s concrete lamina. However bonding of the d/s lamina to the existing section was earned out when the water level in the reservoir was at MDDL (Bond level) or below. Provision for drainage at the interface of the existing masonry and the d/s concrete lamina was also kept.
- 9.11 Almost all the rehabilitation works have since been completed.

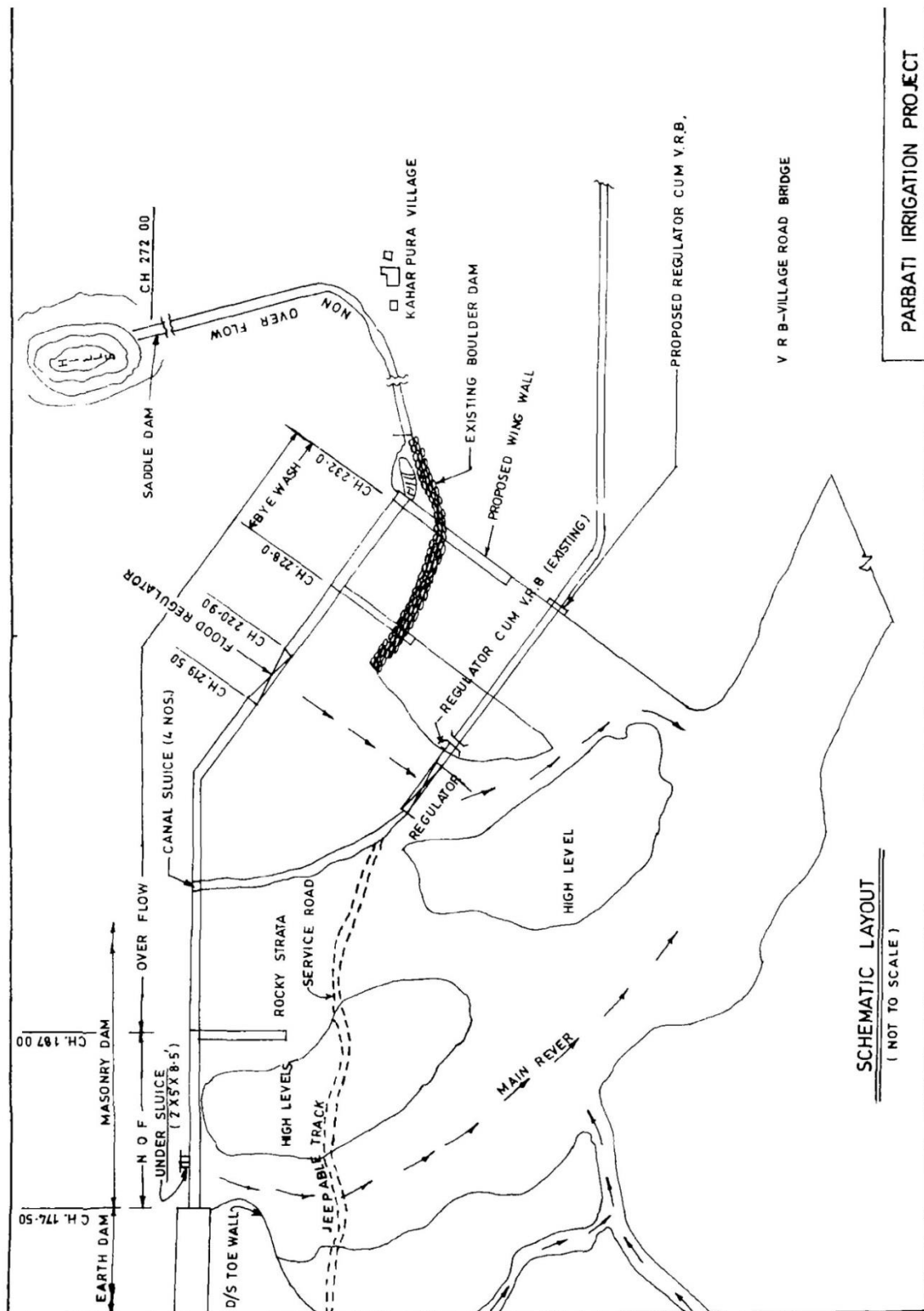

Figure 2 – Schematic Layout of dam

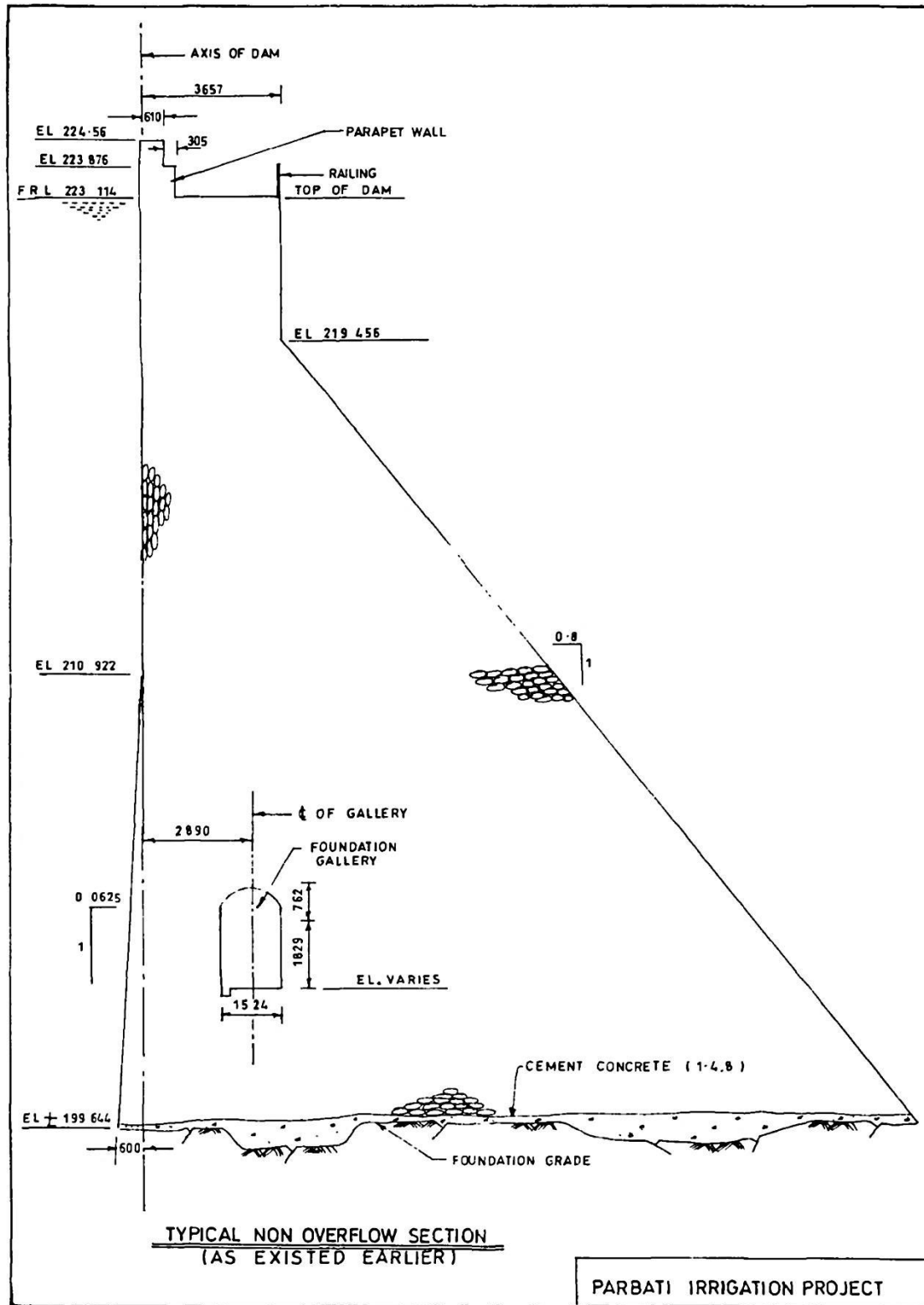

Figure 3 – Non-Overflow Section



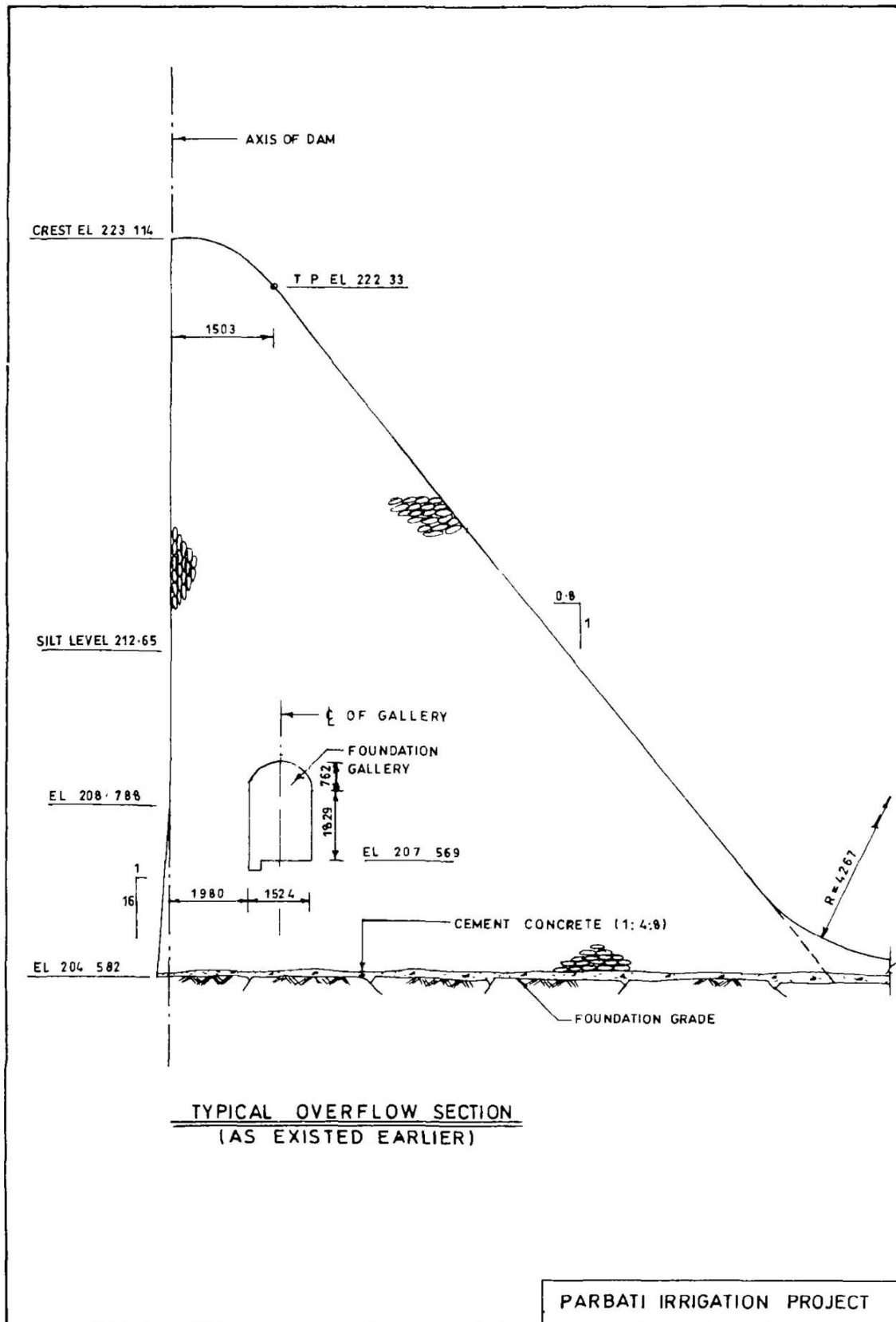

Figure 4 – Over Flow Section

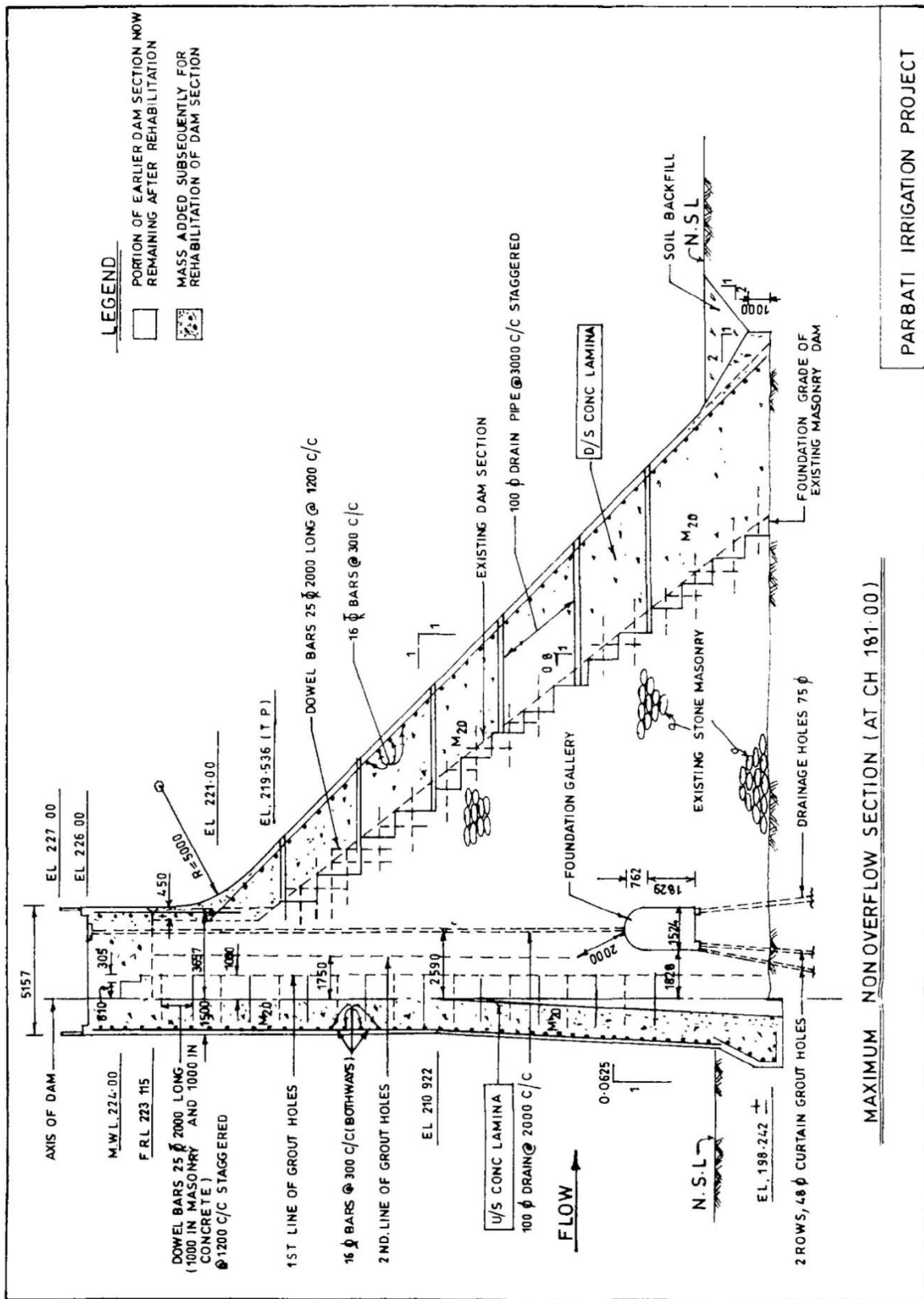

Figure 7 – Maximum Non Overflow Section at chainage 181.00

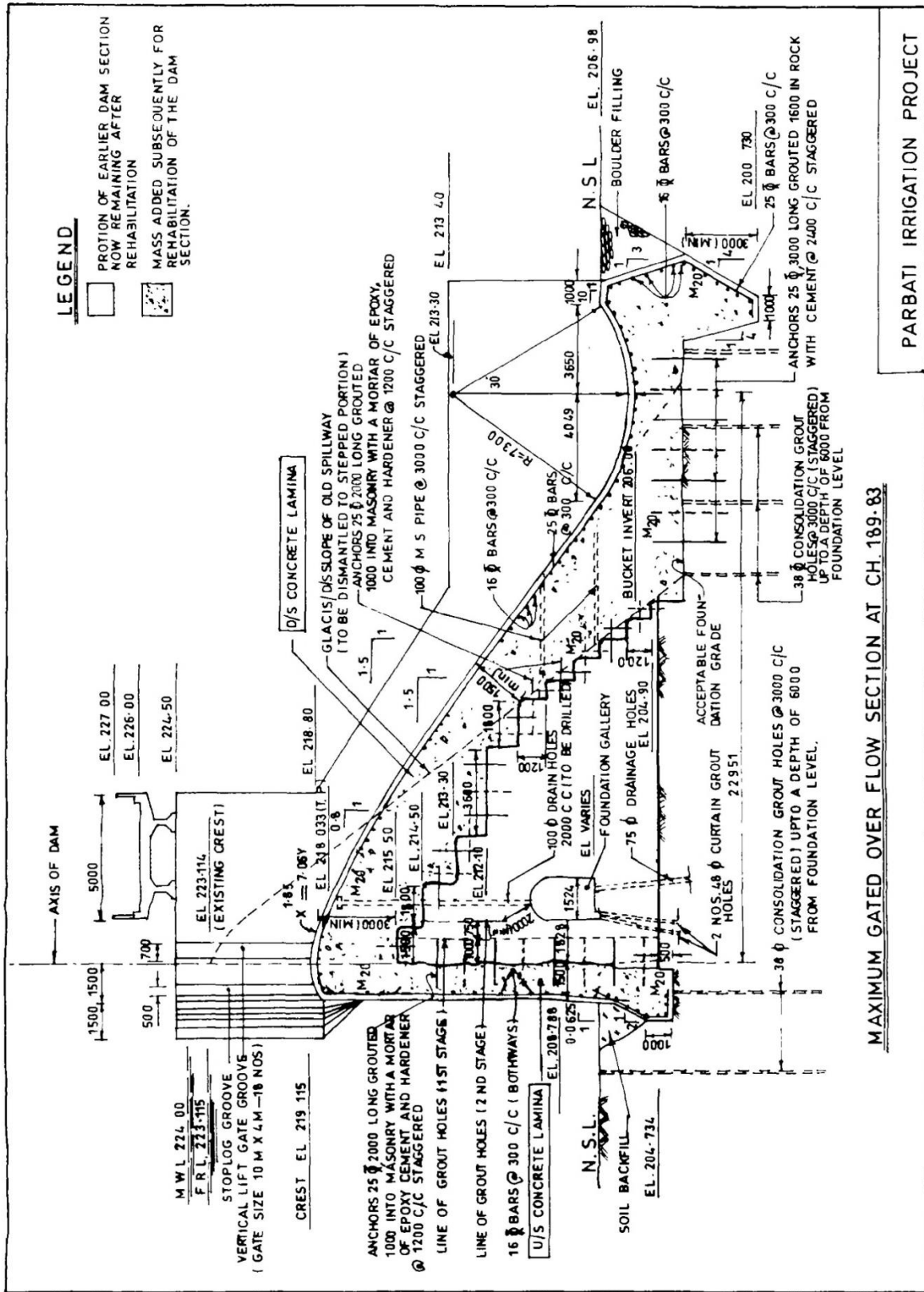

Figure 6(a) – Maximum Overflow Section at chainage 189.83



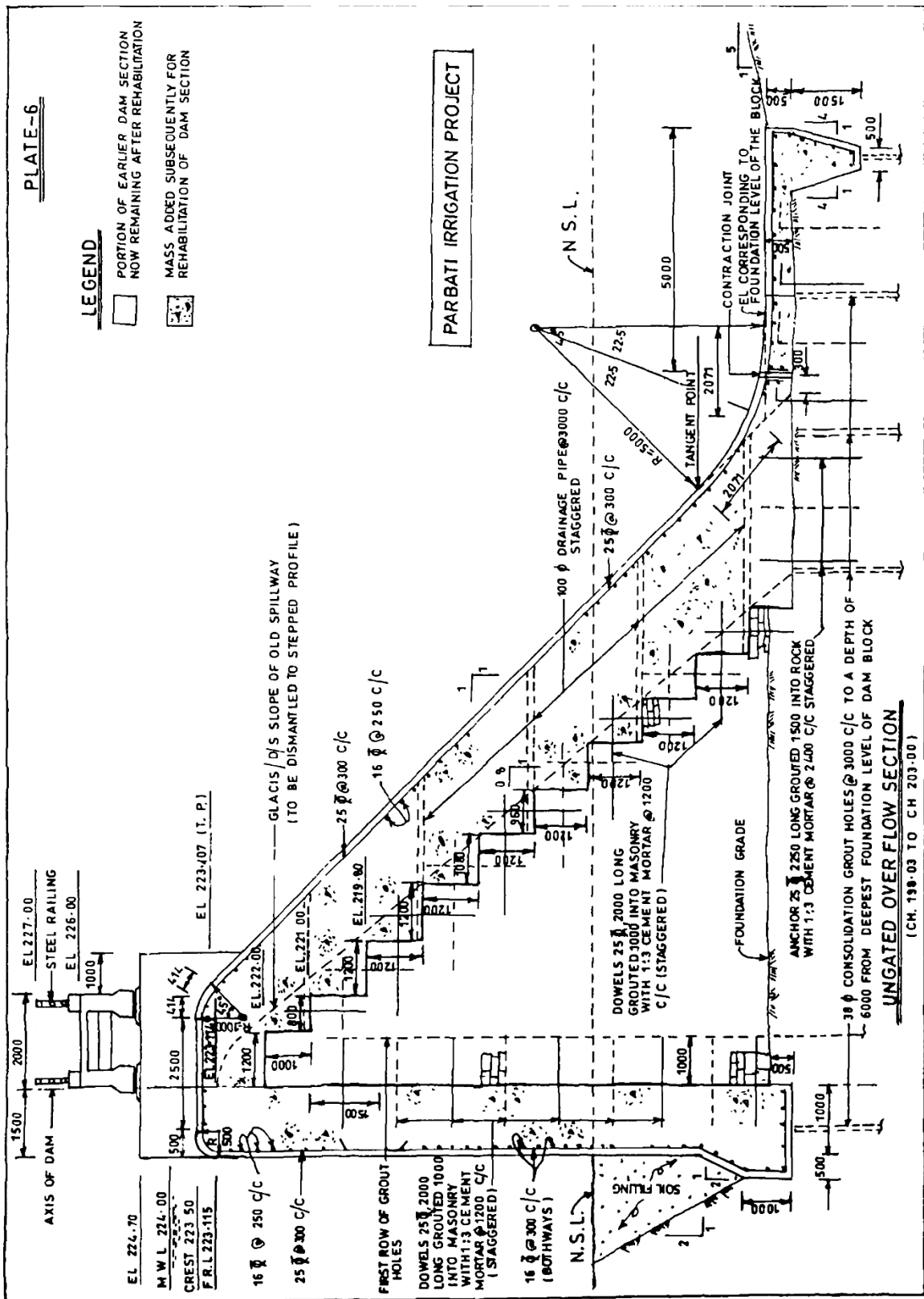

Figure 7 – Un-gated Overflow Section

## Annexure-I

## Salient Features of Parbati Irrigation Project

S.No.	Item	As existed earlier	As modified
1.	FRL	223.114m	no change
2	MWL	224.000 m	no change
3.	TBL		
	(i) Earth dam	226.16 m	226.32 m
	(ii) Masonry non-overflow portion	224.56 m	226.00 m
	(iii) Masonry saddle dam	225.673 m	no change
4.	Catchment area	786.000 sq km	no change
5.	Storage capacity at FRL		
	(a) Gross	115.235 Million cu m	no change
	(b) Live	102.893 Million cu m	no change
	(c) Dead	12.342 Million cu m	no change
6.	Canal sluices		
	(a) Chainage	203.00 to 204.50	no change
	(b) No.	4	no change
	(c) Size	1.22 m x 2.13 m each	no change
	(d) Sill level	212.60 m	no change
7.	Under sluices		
	(a) Chainage	180	no change
	(b) No.	2	no change
	(c) Size	1.22 m x 2.13 m each	no change
	(d) Sill level	200.86 m	no change
8.	Length		
	(a) Earth dam	5318.76 m	no change
	(b) Masonry non-overflow section	426.72 in	477.92 m
	(c) Masonry overflow portion :		
	(i) Gated overflow section	42.67 m	327.66 m
	(ii) Ungated overflow Section	1283.21 m	947.02 m
	(d) Saddle dam	914.40 m	no change
9.	Max. height		
	(i) earth dam	21.90 m	23 m
	(ii) non-overflow masonry dam	24.87 m	27.76 m
	(iii) overflow masonry dam	19.38 m	22.27
10.	Gated spillways	11 gates of size 3.05 m x 2.44 m with crest level at El 220.68 m	(a) 11 gates of size 3.05 m x 2.44 m with crest level at El 220.68 m (b) 18 gates of size 10 m x 4 m with crest level at El 219 115 m (c) 4 gates of size 10m x 7 m with crest level at El 216.115 m
11.	Ungated spillway Crest level	223.114 m	223.50 m



**Data Assumed**

- Density of masonry  $2.09 \text{ t/m}^3$
- Shear parameters at dam/foundation interface  $c = 70 \text{ t/m}^2$   
 $\phi = 33^\circ$
- Horizontal seismic coefficient  $0.06$

Non-overflow Section at El. 199.644 m, *i.e.*, foundation grade level

Load combination	Stress (in $\text{t/m}^2$ )		FOS against sliding as per IS: 6512-1984
	At Heel	At Toe	
A	47.88	2.48	Infinity
B	2.90	36.64	1.8
C	-7.71	36.07	1.8
D	51.93	-0.76	52.1
E	-3.62	42.35	2.4
F	-13.37	34.65	4.5
G	-12.37	40.16	4.0

Overflow Section at El. 204.582 m, *i.e.*, foundation grade level

Load combination	Stress (in $\text{t/m}^2$ )		FOS against sliding as per IS 6512-1984
	At Heel	At Toe	
A	38.99	1.33	Infinity
B	2.68	28.16	2.27
C	-6.13	30.44	1.98
D	42.07	-1.11	63.51
E	-2.34	32.55	2.94
F	-11.48	28.96	5.14
G	-8.87	30.74	5.11

## 10. KOYNA DAM

### 10.1 Preamble

Koyna Hydro-Electric Project is known as life line of Maharashtra. It is a major hydroelectric project in India and is the backbone of energy supply of the National grid with a total installed capacity of 1960 MW. This includes generation of (4 x 70 MW = 280 MW) in First Stage, (4 x 80 MW = 320 MW) in Second Stage, (4 x 80 MW = 320 MW) in Third Stage, (4 x 250 MW = 1000 MW) in Fourth Stage and (2 x 20 MW = 40 MW) in dam-foot powerhouse. Work of (2 x 40 MW = 80 MW) from Dam Foot Pumped Storage Scheme at left bank of the dam is in progress and additional generation of 400 MW is planned in near future (2 x 200 MW = 400 MW) from Stage-V and (2x200 MW=400 MW) from Stage-VI. Stage-V and VI are also planned as Pumped Storage Schemes (see Photograph 1).

In the Indian Sub-Continent Koyna Project has several “firsts” to its credit, in which under water lake-piercing technique adopted with enormous success for its Stage-IV and IV(B) construction, is worth mentioning.

After independence, the increasing power demand from the industrial sector gave boost to many projects in India. Koyna was one of those selected projects which even today is the largest hydroelectric project in the State that accounts for about two thirds of the State’s hydel installed capacity. Though initiation of planning of this project dates back to 1910 during British regime, the detailed investigation work was completed during 1947 to 1950. Several construction techniques were thought of, tried and tested for their efficacy and the best suitable for Indian conditions was finally adopted. Koyna Dam is a principal component of this mega-project. It is a 103 m high rubble concrete dam constructed in two stages across the river Koyna, a tributary of river Krishna that is a major river in Indian peninsula. It was for the first time in India that such a monumental structure was built in rubble concrete instead of conventional concrete or uncoarsed rubble (U.C.R.) masonry. With optimum cement content of the order of 177 kg/m<sup>3</sup>, densities as high as 2.65 t/m<sup>3</sup> and 90 days’ strengths to the tune of 2100 t/m<sup>2</sup> were achieved through scrupulous quality control. The dam construction was started in 1957 and impoundment was started from 1961. The earthquake parameters for evolution of design were decided on the basis of general trend and the seismological data then available. The total length of the dam is 807.72 m. It comprises of 53 monoliths in total. Out of these, six shallow



Photograph 1: View of Koyna Dam

monoliths are constructed in UCR masonry and the rest 47 in rubble concrete. The central spillway comprises of seven monoliths from monolith 18 to 24. The length of the spillway is 89.0 m. divided into six equal spans. Radial gates of size 12.41 m x 7.46 m are provided. These gates are attached with 1.5 m high flaps to raise the Full Reservoir Level (FRL) by 1.5 m. The Energy Dissipation Arrangement (EDA) is of sloping apron type with appropriate appurtenant structures. The original storage capacity of the reservoir is 2797 Mm<sup>3</sup> with 2503 Mm<sup>3</sup> of live storage which is now increased by 184 Mm<sup>3</sup> due to raising of F.R.L. by 1.52m.

## 10.2 Seismic activity in the area

The Koyna dam is founded on the trap formation of volcanic basalt of Deccan plateau of the peninsular India. The trap formations are almost horizontal with irregular interfaces. Deccan plateau was not known for any major historic seismic event in the past. Thus there is no record of major seismic activity in the region. Seismological stations in this region were established during the construction stage of the dam. In early sixties small tremors were experienced and recorded. By that time the construction of the dam had progressed considerably and partial impoundment up to Koyna Reduced Level (KRL) 632.6 m was created. Since 1962 quite a few small shocks were recorded in the reservoir area. The frequency of this seismic activity increased considerably from 1963 onwards.

### 10.2.1 Koyna Earthquake of 1967

It was not even dreamed in 1961-62 that the Koyna dam area would soon turn out to be seismically active on a large scale. But on 11th December 1967, a severe earthquake shock having a magnitude of 6.5 on Richter's scale was felt in this area releasing enormous amount of energy. The epicenter of this shock was just about 3 km away on the downstream of the Koyna dam. The occurrence being so close to the dam, it resulted in noticeable distress to the body of the dam in the form of horizontal cracks at quite a few locations. Horizontal cracks on the u/s and d/s faces of some deep non-overflow (NOF) monoliths were noticed. In addition, the appurtenant structures like components of the spillway bridge and the elevator tower showed distress in the form of spalling and cracking of concrete etc. However, the spillway portion of the dam remained fairly intact.

Most of the damage occurred in NOF section and the place where an abrupt and severe



Photograph 2: Downstream view of Koyna Dam

change of slope was provided on the d/s face at KRL 627.9 m. These abrupt changes in the slope were made while accommodating the Stage II construction of the project over Stage I construction already completed. This also increased inertia mass at top due to wider top widths resulting in high stress concentrations at these locations under severe dynamic conditions.

This was the first time in the history that an epicentral earthquake having such a high magnitude was experienced by a large gravity dam. Naturally it attracted attention of experts on the global scale. All these experts tried to correlate several entities for the cause of the disaster including reservoir-induced seismicity. Based on their opinions and findings several papers were also published in that decade. Government of India (GOI) in consultation with the UNESCO appointed a committee of International Experts in 1968 to study the extent, causes and consequences of the damage and suggest remedial measures for strengthening of the dam.

### 10.3 Necessity of Strengthening.

The experts committee suggested several temporary as well as permanent measures. The temporary measures included offloading the reservoir.

- Grouting of the cracks by epoxy resins.
- Guniting the u/s surface.
- Anchoring the top portion of dam to the bottom portion with the help of prestressed cables.

These works were done immediately before the monsoon of 1968

As the NOF portion had indicated distress at various locations, various analyses and studies by Finite Element Method (FEM) technique and also testing of physical models on shake table in Japan, permanent strengthening measures were suggested by the experts committee in the form of buttresses to the shallow NOF monoliths. This included provision of shear keys in between the original face and the buttress back. The design was complex and needed elaborate construction planning and arrangements. For the deeper monoliths strengthening was suggested by full concrete backing with provision of adequate shear keys upto KRL 600.456 m above which buttresses covering about half the monolith width were provided upto KRL 653.796 m. The design criteria adopted for the Rehabilitation measures were,

- No tension in Pseudostatic analysis with  $\alpha_h = 0.2$
- Tension upto  $300 \text{ t/m}^2$  under dynamic conditions with seismic coefficient of 0.5 g.

The overflow (OF) portion was devoid of any noticeable distress and hence it was not felt necessary to strengthen it along with the NOF portion in those days.

#### 10.3.1 Killari earthquake of 1993

After major earthquake of Koyna of 1967 the Deccan plateau remained tectonically active with occurrence of earthquakes of small to mild intensities in and around Koyna-Warana basins till the year 1993. Again in the year 1993, Deccan plateau gave a big surprise to the engineering community in the form of Killari earthquake. On September 30, 1993, the Marathwada region of Maharashtra State was hit by an earthquake of 6.3 magnitude on Richter's scale at Killari. The result of this tectonic activity was so pathetic that the Government of Maharashtra had to re-evaluate the standards and commonly adopted norms for 'seismic design' of existing dams. The Government in due course constituted a

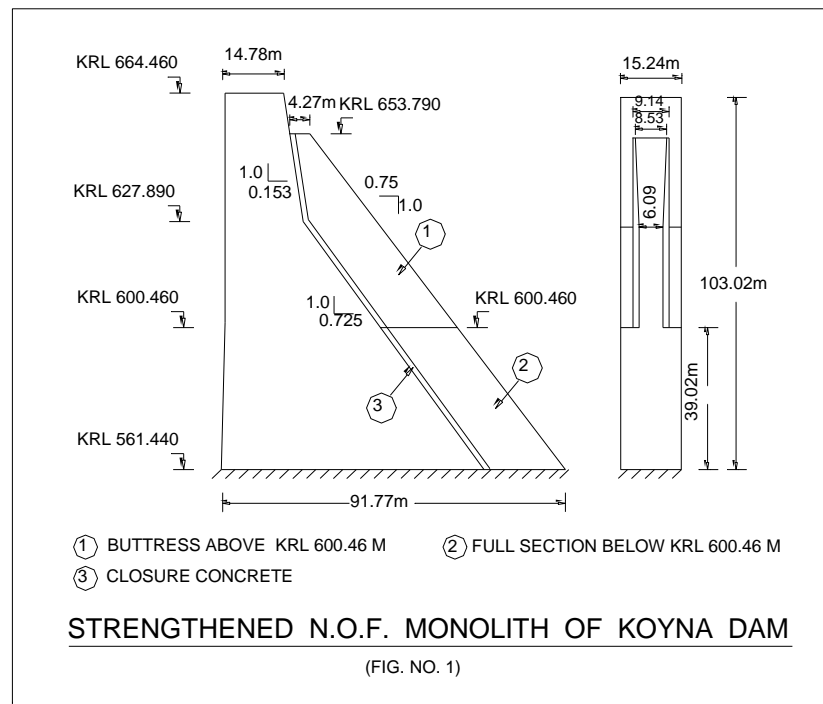

committee under the chairmanship of Shri. V. R. Deuskar, Rtd. Secretary, Irrigation Department, comprising of eminent personnel from the Indian Engineering Community. The scope of this committee was to :

- Review safety of all the 27 medium and major dams located in the earthquake-affected regions after deciding on the modifications to be carried out in design standards.
- The committee was also asked to check the necessity of strengthening of these dams and to suggest appropriate strengthening measures to be adopted based on the revised seismic parameters. These dams included Koyna and Kolkewadi dams under the Koyna Hydroelectric Project. The committee submitted its report to the GOM in 1997, which was accepted in early 1999.

### 10.3.2 Recommendations of the Deuskar Committee

The committee studied the Koyna dam in detail with revised earthquake parameters and confirmed that the NOF section of Koyna dam that was already strengthened with concrete backing after 1967 Koyna earthquake, is safe even for the proposed raising of FRL by 1.52 m i.e. upto KRL 659.43 m. Similarly, the expert committee studied the efficacy of the OF section for revised seismic parameters and recommended the necessity of its strengthening even without the proposed raising. The committee recommended to,

- Design the Over Flow section considering the raising of FRL by 1.52 m for 0.332 g PGA and for the accelerogram generated corresponding to the Maximum Credible Earthquake (MCE) of 6.8 magnitude measured on Richter's scale by dynamic analysis.
- Conduct comprehensive physical hydraulic model studies for the proposed profile of the OF section and energy dissipation arrangements.

## 10.4 Evolution of the Strengthening Section

The design philosophy adopted for spillway strengthening was to decide the preliminary section using Pseudostatic analysis with some margin for the stresses and then carryout detailed 2-D FEM analysis on the section thus arrived to find its efficacy under dynamic conditions and finally check the strengthened section from hydraulic point of view.

### 10.4.1 Pseudostatic Analysis

The pseudostatic analysis carried out for the seismic parameters recommended by the experts committee clearly indicated tension on the U/S face with a maximum value of  $149 \text{ t/m}^2$  for the critical load combination 'G' (dam at F.R.L. + Earthquake + Extreme uplift). According to the provision of Indian Standard 6512-1984, the maximum tension allowed for 'G' condition is  $0.04f_{ck}$  i.e.  $84 \text{ t/m}^2$ . It was evident that the dam needed strengthening of the u/s face. However, considering the depletion restraints imposed by probability of disruption of power generation, it was impracticable to carry out any strengthening measures on u/s face. It was, therefore, decided to flatten the d/s slope so that the heel stresses were reduced to the desired extent. Various trials with different slopes indicated that flattening of the d/s slope up to 1(V):1.1(H) appreciably reduced the tension. For the load combination 'G', maximum tension observed was  $61.3 \text{ t/m}^2$ , which is less than the permissible value of  $84 \text{ t/m}^2$ . This section was adopted for further dynamic analysis studies.

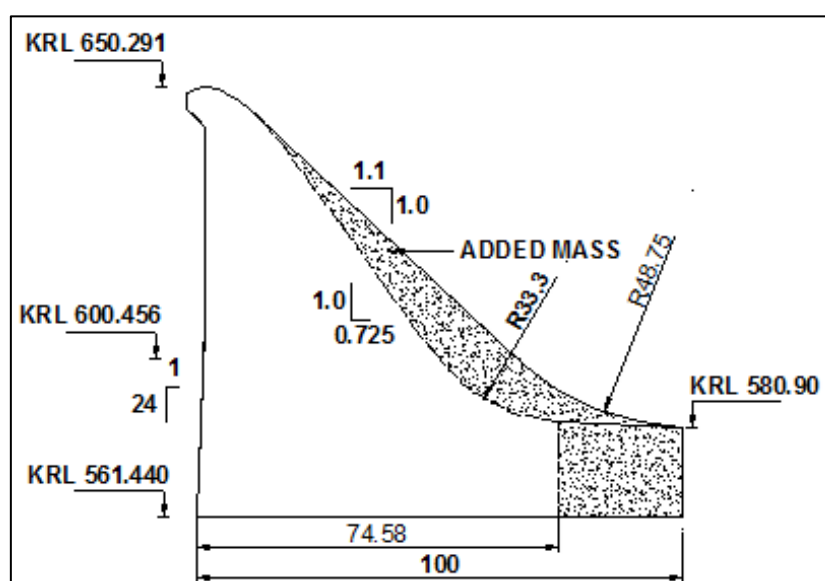

Figure 2: Strengthened Over Flow Section of Koyna Dam

The details of the input parameters and the results of pseudostatic analysis are furnished as following.

Details of input parameters:-

i)	Concrete unit weight .....	$2.65 \text{ t/m}^3$
ii)	Top Bund Level .....	664.464 m
iii)	Maximum Water Level.....	661.337 m
iv)	Full Reservoir Level.....	659.434 m
v)	Foundation Level.....	561.440 m
vi)	Horizontal Seismic Coeff. ( $\alpha_h$ ) at top..	0.407



vii) Vertical Seismic Coeff. ( $\alpha_v$ ) at top..... 0.271

Stresses at Foundation Level (KRL 561.440)

For Load Combination G (FRL+EUL+EQ)

Stress @ Heel ( $t/m^2$ )	Stress @ Toe ( $t/m^2$ )
-61.3 (Tension)	192.05 (Compression)

#### 10.4.2 Dynamic Analysis

The dynamic analysis was performed using a software developed by Prof. Dr. Saini from I.I.T., Roorkee and another software EAGD-84 (developed by the University of Berkeley) and It was observed that the value of  $E_{dy}$  of concrete (dynamic modulus of elasticity) used in this analysis has more impact on the results than any other parameter. The value of  $E_{dy}$  used was  $5.8 \times 10^6 t/m^2$ . The tensile stresses obtained in the FEM analysis with the new section were above  $450 t/m^2$  at a few locations, which were very high as compared to the permissible value of  $300 t/m^2$ . As such the Board of Consultants for Koyna Project recommended use of realistic values of  $E_{dy}$  of concrete in the analysis. An experiment was conducted on the 16 cores extracted from the dam body. Out of these 8 cores were from over flow portion of Koyna dam. These cores were subjected to sinusoidal loads with different frequencies and deformation time histories were obtained. Based on these the value of  $E_{dy}$  was determined by method of superposition. Experiment was done in the IEOT laboratory of ONGC, Panvel with the help of CWPRS, Pune which gave the  $E_{dy}$  value of  $4.59 \times 10^6 t/m^2$  as against earlier assumed value of  $5.8 \times 10^6 t/m^2$  obtained from mathematical model studies.

#### 10.4.3 Final analysis for strengthening section.

Based on the  $E_{dy}$  value of  $4.59 \times 10^6 t/m^2$ , the dynamic analysis was carried out for the three different accelerograms viz. Koyna EQ (actual recorded on 11<sup>th</sup> Dec 1967), ARC (A.R.Chandrashekharan) and CW&PRS (Central Water & Power Research Station) later two of which were synthetic accelerograms, developed for similar sites. Softwares mentioned above were used for these analyses. Results of these analyses and sections showing the stress contours are furnished below.

Case I: Maximum Tensile Stresses using ARC Accelerogram with Peak Ground Acceleration (PGA) 0.332g

Face	Node No.	Stress ( $t/m^2$ )
Upstream	139	1037
Downstream	130	934

Case II: Maximum Tensile Stresses using Warna Specific Accelerogram with PGA 0.46 g

Face	Node No.	Stress ( $t/m^2$ )
Upstream	383	986
Downstream	130	765

Case III: Maximum Tensile Stresses using Koyna Spec. Accelerogram with PGA 0.6416 g

Face	Node No.	Stress ( $t/m^2$ )
Upstream	383	962
Downstream	130	815

**MAXIMUM TENSILE STRESS CONTOURS FOR KOYNA SPECIFIC ACCELEROGRAM**

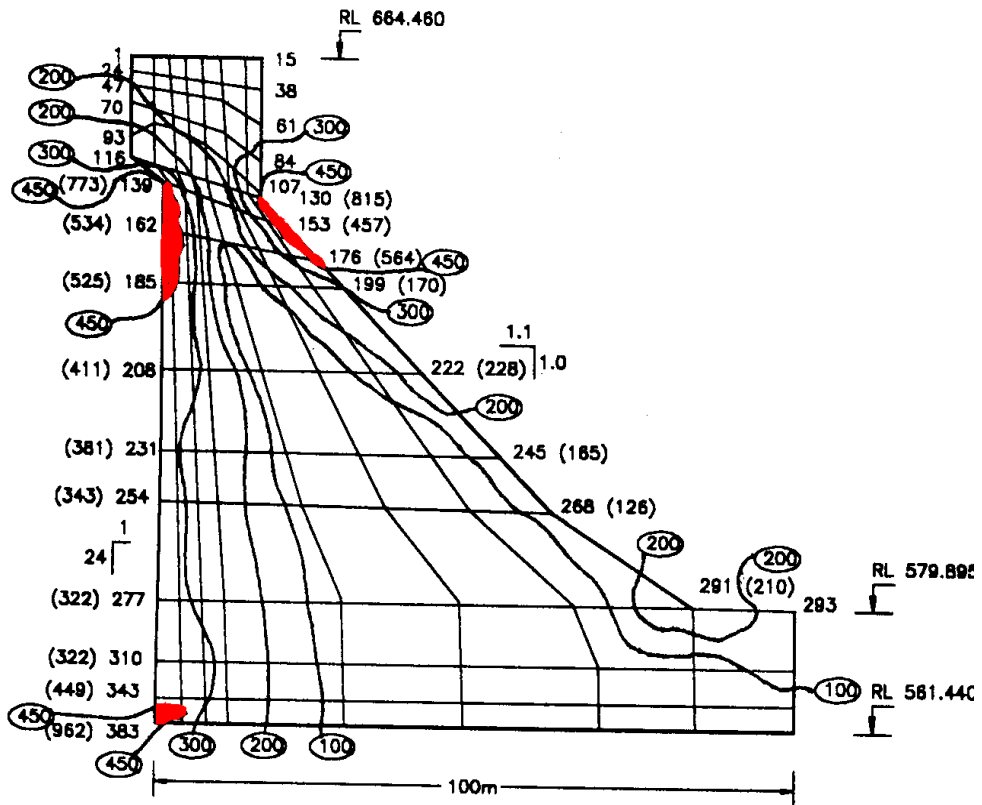

**MAXIMUM TENSILE STRESS CONTOURS FOR ARC ACCELEROGRAM (PGA:0.332g)**

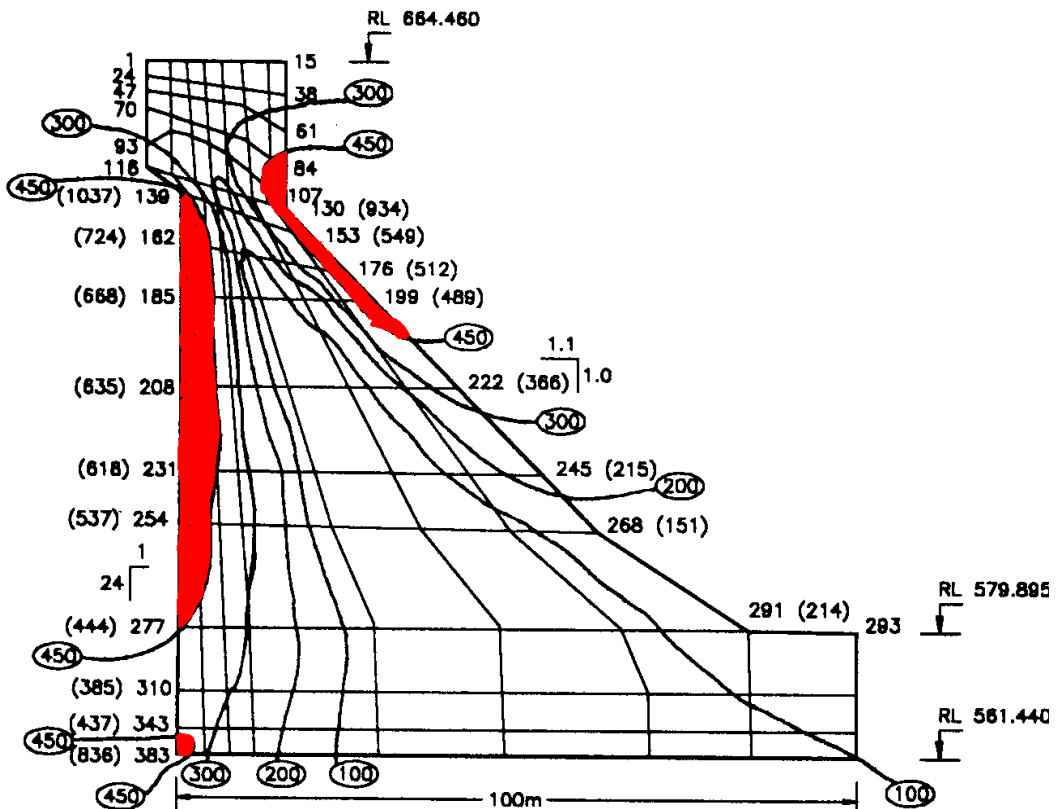

**MAXIMUM TENSILE STRESS CONTOURS FOR WARNA SPECIFIC ACCELEROGRAM**

Figure 3: Values in bracket indicates Tensile Stresses in t/sq.m.

It could be observed that the values of the tensile stresses were for Maximum Considered Earthquake (MCE) condition and at singular points where change in geometry & stiffness of the section were predominant. In rest of the section the tensile stresses were reasonably within the permissible limits (corresponding to the apparent seismic tensile strength of 540 t/m<sup>2</sup> for the rubble concrete of OF portion of Koyna dam). After deliberations with the Board of Consultants for Koyna Project, the strengthening section having slope of 1(V):1.1(H), which envisaged providing full concrete backing, was adopted for the strengthening of overflow portion of Koyna dam to cope with the raising of FRL and revised seismic parameters.

#### 10.4.4 Hydrological Aspects

In the process of design of the strengthening section the hydrological aspect was also of major consideration. This aspect was important as the flood routing studies were to be conducted for the raised FRL of 659.43 m. These studies were carried out for the PMF corresponding to 68.38 cm rainfall in 24 hours. The catchment simulation study indicated probable maximum flood (PMF) of 17095 m<sup>3</sup>/s. With unrestricted releases, the MWL computed was KRL 661.20 m. Based on this MWL and the corresponding spillway discharge of 5738 m<sup>3</sup>/s, the preliminary design of the EDA was evolved. Model studies on 1:50 ground scale model for evolution of final layout & design of EDA were carried out by the Maharashtra Engineering Research Institute, Nashik.

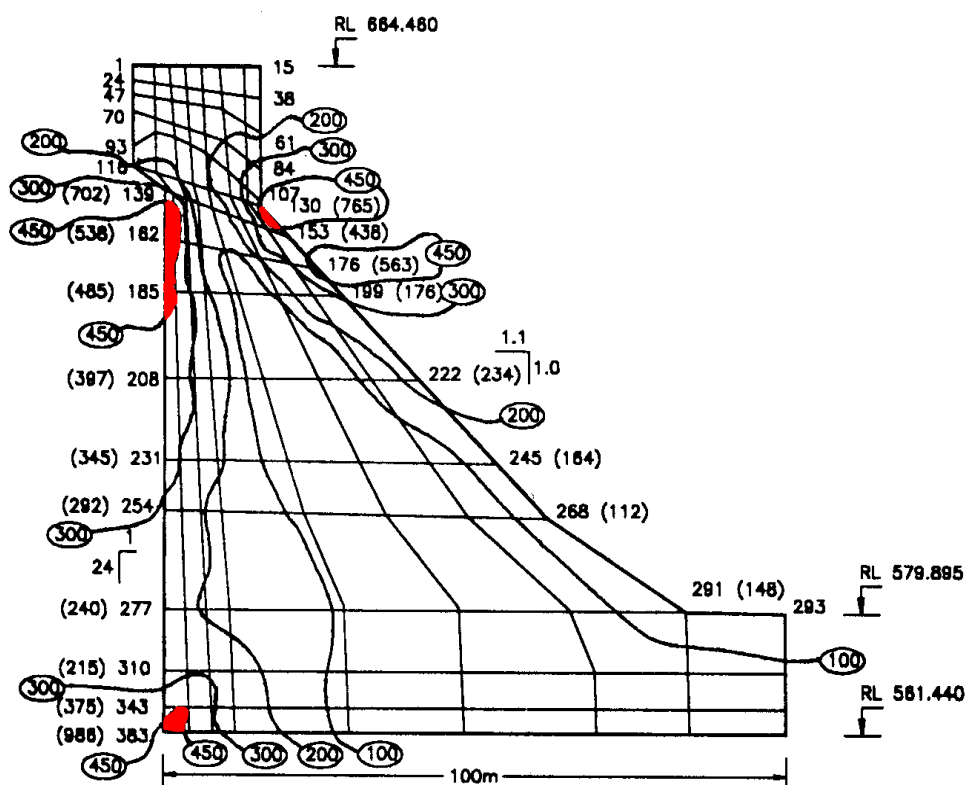
#### 10.5 Construction Planning and Methodology

The scheme of strengthening included providing full concrete backing of rubble concrete from the level of original dam foundation (KRL 561.44m) to the upper tangent point of

ogee (KRL 645.0m). This concrete was to be essentially of the same grade and strength as that of the original dam. To overcome the interface problems between the old and the new concrete, it was decided to first cast the strengthening concrete with a gap of 1.2m, allow it to cool and shrink for at least 30 days and then join it to the dam body by closure concrete. This was to be done when the reservoir level is at the predetermined level known as Bond RL, to account for the locked up stresses in the body of the dam, since the dam could not be emptied during the strengthening work for the reasons mentioned earlier.

Strengthening of spillway portion of any dam with full backing is essentially a time bound work especially so when the dam is to be kept in operation during the strengthening work. It is for the first time in India that the spillway of such a large dam as Koyna is being strengthened. The Water Resources Department of Maharashtra State had carried out the strengthening works of NOF sections of various dams in the past but this particular work needed meticulous planning and adoption of equally competent construction methodology for its successful completion.



Figure 4: 1:50 GS Model Study at MERI, Nashik

After studying various intricacies of the proposed strengthening work and the available expertise for performing this work, it was planned to complete the said work in two seasons (i.e. Oct.2004 to May 2006). In the first year i.e. From Oct. 2004 to May 2005, it was planned to complete the strengthening work up to KRL 580.90m i.e. below riverbed portion. This also included the extension of stilling basin, construction of new end weir, raising the guide walls of EDA and excavating and back filling with concrete the 25 m wide, 20 m deep and 90 m long foundation block. The first year's strengthening work included 76000 Cum of rock excavation with controlled blasting, 85000 Cum soil excavation, 32000 Cum conventional concrete, 3000 Sqm of pressure grouting, reinforcement, anchoring and 36000 Cum backing concrete of grade M21 with MSA 150mm and 2000 Cum closure concrete. To complete this work suitable machinery like concrete batching plant of 150 Cum/hour capacity was installed at site, for precooling the concrete, 105 MT/day capacity ice plant, stone crusher of capacity 125 Tons/hour etc. and other state-of-the-art equipments and machinery was also deployed at the site.

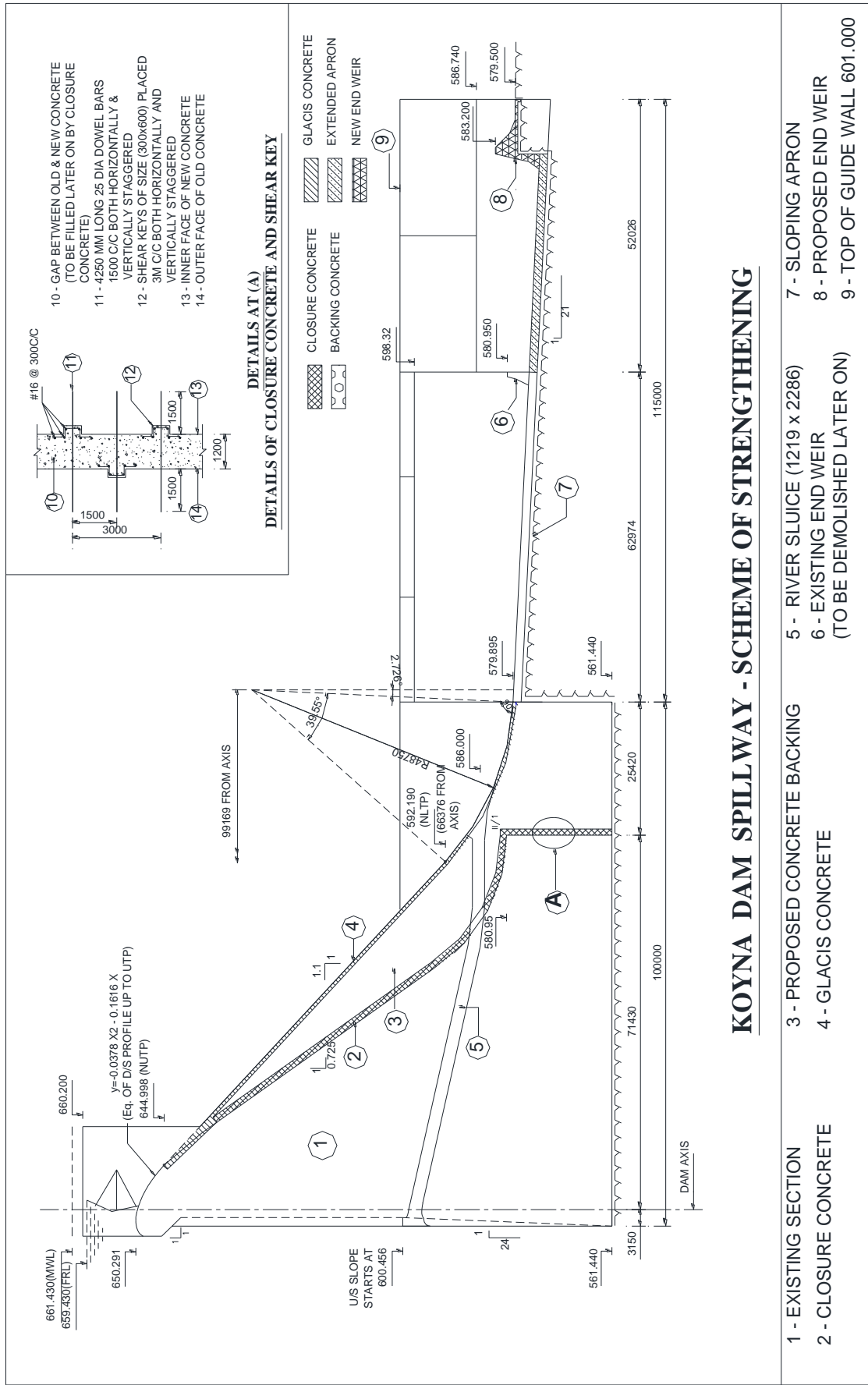

(Fig. No.5)

In second year construction work i.e. from Oct. 2005 to May 2006, strengthening of OF section from KRL 580.90m to KRL 645.0m (UTP of OF section) would be completed. In this season 52000 Cum of backing concrete, 9000 Cum of closure concrete and 10000 Cum of other concrete would be placed.

Studying all possible difficulties in construction, the construction planning was done in such a way that the both the season's targeted work would be completed before start of monsoon at the end of every season.

#### 10.6 Challenging and time bound work of excavation at the toe of the dam

Total 70000 cum excavation in hard rock was necessary for foundation block and for extension of stilling basin at the toe of dam. Though sound rock was available at riverbed level itself, due to underlain volcanic breccia layers and structural design requirement to increase the dam section right from original foundation level and hydraulic performance requirement of EDA as resulted through model studies, the excavation in intact rock was mandatory. Controlled blasting was certainly warranted, but this was not usual open ground excavation. The work area was very close to the dam proper and also to the Dam toe Power House. Due to hydropower commitments along with irrigation and drinking water requirements in the region, closure of the powerhouse was impracticable. At the same time blasting was to be completed within stipulated time frame to avoid future deviation in construction programme. This particular problem was referred to Central Water and Power Research Station, Pune for study and recommendations of blasting pattern, blasting material to be used etc. Detailed studies and trial blasts in similar rock type on nearby site were carried out to find out the attenuation characteristics of the foundation rock. The primary objective was to safeguard the dam and dam foot power house and also the other nearby structures from the ill effects of blasting viz. blast vibrations characterized by Peak Particle Velocity (PPV), fly rocks and air over pressures. After detailed studies and analysis the safe PPV for dam was stipulated as 70 mm/s and for powerhouse as 10 mm/s. The entire excavation plot was divided into five zones. Blasting pattern, quantity of blasting material, depth of holes etc. was finalised for each zone considering the limitations on PPV. The accompanying sketches show the plan and cross section of the blasting area and the methodology adopted. The blast vibrations were measured using Instantel (Canada) - make Seismograph kept both at the dam toe and in the power house. Frequency content of blast vibrations and the air overpressures were also measured. In all 770 blasts were taken. The following table depicts the control and monitoring achieved during excavation by control blasting. The excavation was completed successfully ahead of schedule.

PPV (mm/s)	Below 20	20-40	40-50	above 50	Total
	741	22	3	nil	770

Air over-pressures recorded were less than 120dB for all the 770 blasts. Frequency content of blast vibration was more than 60 Hz in 723 cases and less than 60 Hz in only 47 cases.



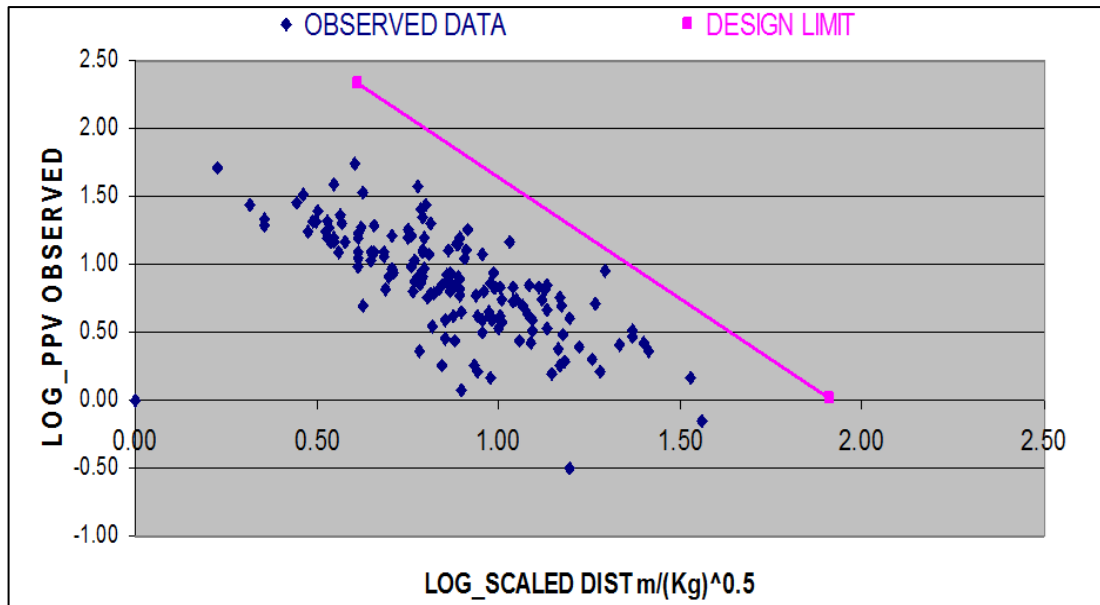

Figure 6: Graph Showing PPV recorded and Allowable limit

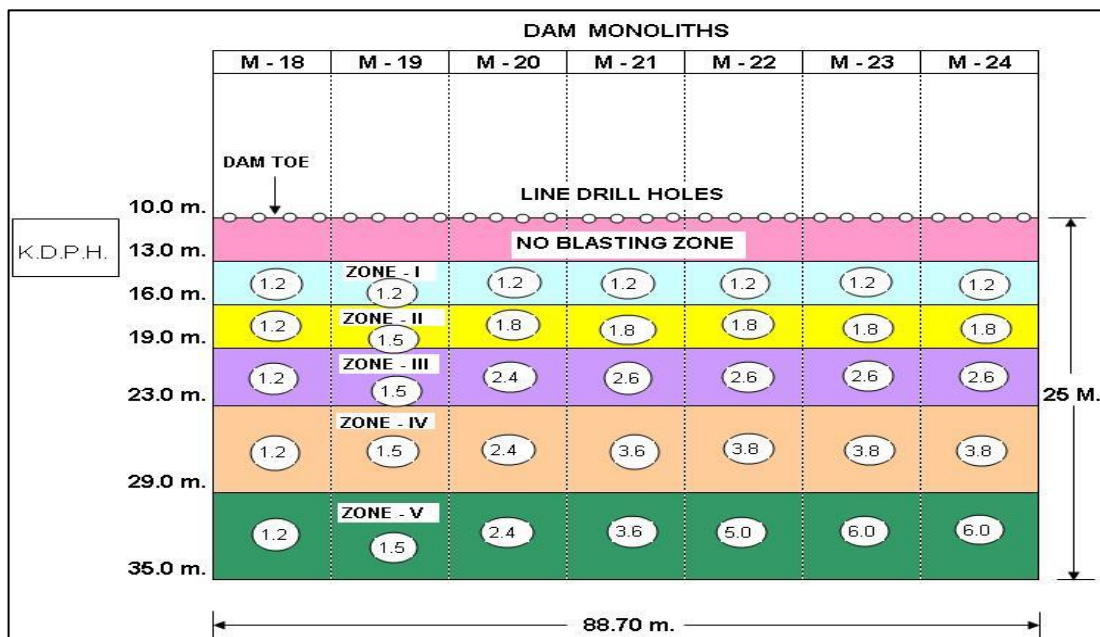

Figure 7: Drawing showing the blasting zones and charge per delay

10.7 Concrete Placement

Placing of the backing concrete in position is one of the important activities. Time period available for concreting was very limited due to construction activities like completion of blasting, restriction of concrete lift height and minimum required period between two successive lifts from heat of hydration point of view etc. Before starting the concreting no of alternatives were studied to prepare mix design to satisfy the design requirements like minimum unit weight of 2.65 t/Cum and minimum compressive strength of 2100 t/sqm with as little cement as possible. The cement content governs the heat of hydration during setting of concrete. Finally, M21 grade concrete with 177 kg/cu.m. of cement was designed in the project laboratory, the refinement work was done later on by the IIT, Mumbai.

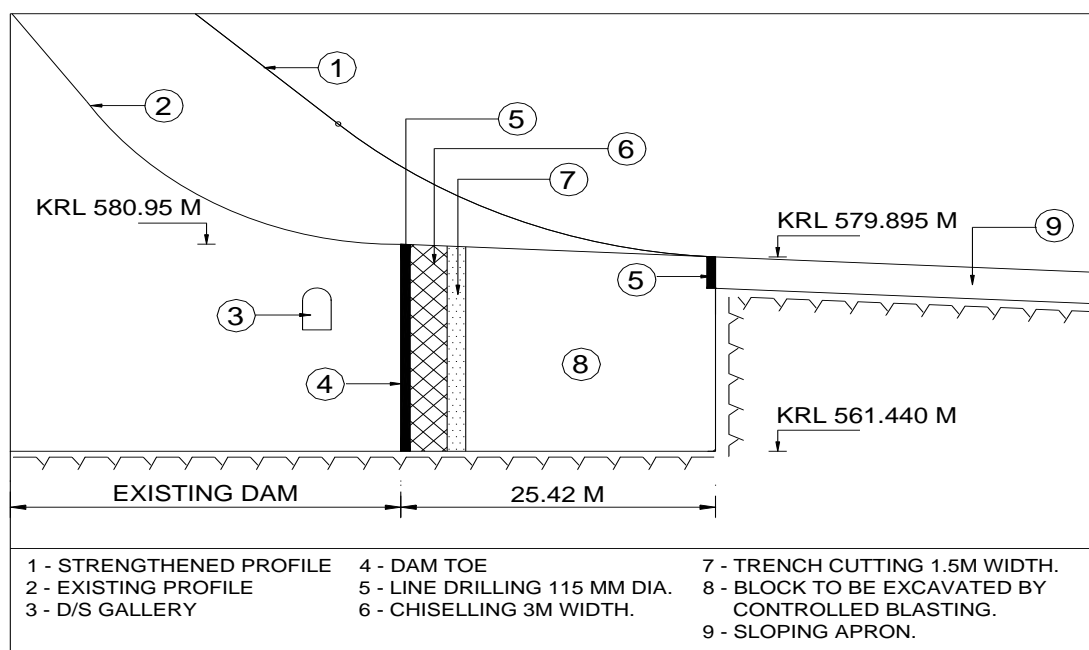

Figure 8: Sketch showing the methodology of controlled blasting

### 10.7.1 Mix Design

Plum concrete using 150 mm size plums and with an effective cement content of 177 Kg/m<sup>3</sup> was used for construction of original dam. It was thought that using the state-of-the-art high-speed mixers of sufficient capacity, a more cohesive concrete mix of 150 MSA could be obtained very easily. The concrete placed in the 1.2m gap between the new strengthening concrete and old dam concrete was of M20 grade with cement of 200 Kg/m<sup>3</sup> and 80MSA.

The initial mix designs were done in Koyna laboratory and for further refinement the mix design was done by the IIT Mumbai. The proportion of ingredients is shown in the following table.

Mix	Cement (Kg).	Coarse Aggregate (Kg)					Fine Aggregate (Kg)		Water (ltr)	Admixture (ml)
		150-80	80-40	40-20	20-10	10-4.75	Sand	Grit		
Strengthening Concrete	177	897	243	243	194	121	364	364	106	1200
Closure Concrete	200	--	858	348	232	186	348	348	120	860

The water as above was partially replaced with flake ice 50-70% based on the requirement to achieve the placement temperature.

Next important job was to design the thickness of lift, minimum curing/cooling period required before placing next lift, method of cooling of concrete like precooling and/or post cooling etc. This thermal study of backing concrete was also carried out with help of

CWPRS, Pune. Studies to find out various properties of concrete like tensile and compressive strengths, tensile strain capacity, coefficient of thermal expansion etc. on the various samples of backing concrete were carried out in the laboratory at Pune as well as some in-situ tests were carried out. From this study the lift of backing concrete as 1.50m, minimum gap between two successive lifts as 3 days were finalised. In view of the constraint on the construction schedule pre-cooling as well as post cooling was resorted to. Precooling was to be achieved by adding chilled water and ice flakes during mixing concrete in batching plant and post cooling with circulating chilled water through embedded G.I. pipes in backing concrete for at least 30 days. The recommended placement temperature for concrete was 18<sup>0</sup> C and that of chilled water used for post cooling was 22<sup>0</sup> C. The cooling water was circulated in the concrete through G.I. pipes embedded in concrete in the form of pipe network with 1.0m horizontal spacing and 1.5 m vertical spacing. Following photograph shows the post cooling pipes embedded in concrete. A graph of inlet and outlet temperature of the post cooling water and the resulting concrete temperature obtained from the thermocouples embedded in the concrete is enclosed which gives the extent of control on the concrete temperature achieved. A maximum temperature of 44<sup>0</sup> C was envisaged in the thermal analysis against which temperatures of 38 to 41<sup>0</sup> C were recorded actually by the thermocouples.



Figure 9: Photograph showing concrete placement and post cooling arrangement



Figure 10: Photograph showing Second Year Strengthening work in progress

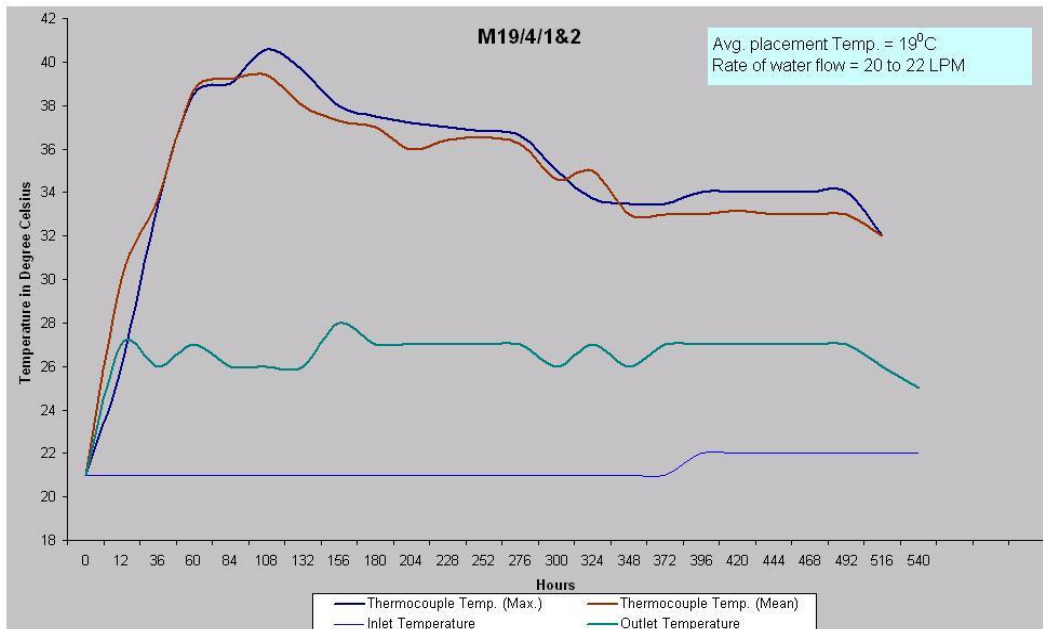

Figure 11: Graph showing results of post cooling and concrete temperature



## 10.8 Problems faced and remedial measures.

## 10.8.1 Excavation of rock covered by RCC layer:



Line Drilling 115 mm dia 400 mm c/c upto full depth to provide separator between Dam & excavation plot



Figure 12: Breaking of reinforcement to enable concrete excavation and Face opening for concrete excavation is done

The foundation portion of the extended dam was previously the sloping apron of the stilling basin and as such it was covered with reinforced concrete. The thickness of the concrete varied from 70 cm to 270 cm. Initially it was planned to excavate the concrete and the rock in a similar manner. When drill holes were taken in the concrete and blasted, the holes used to get blown off. Sometimes the underlain rock used to get shattered

but the concrete provided a comparatively unaffected surface. This was because of the presence of the reinforcement in the concrete.

To overcome this problem, the concrete top was first broken using hydraulic breaker in the form of grid of 3m x 3m, to expose the reinforcement. The reinforcement bars were then cut using gas cutters. Regular drilling blasting as per the pre-determined pattern gave very good results later on.

#### 10.8.2 Cutting of shear keys



Figure 13: Cutting of Shear Keys

Shear keys were cut in the old concrete to have a proper bonding between the old concrete and the new strengthening concrete via closure concrete. Therefore, the success of the bonding depended upon the efficacy of the shear keys. However the cutting of shear keys was not only a difficult job but also a time consuming one. Efforts were made to cut these shear keys while the excavation was in progress to save the time during concreting period. However, the cutting went on lagging behind and subsequently it was abandoned at certain locations as the excavation which was equally critical and time bound could not be stopped. Once the concreting started, the hydraulic breaker could not be employed for cutting the shear keys. And also, as the concreting progressed as per the time schedule, it was difficult to work with the usual tools in the limited space of 1.2 m between the two concretes. One innovative method of using drilling and splitting concrete solved this problem. The concrete face where shear keys are to be cut was drilled using 50 mm dia drill for a depth equal to the size of the shear key. Hydraulic splitter was used to wedge out the concrete in this portion. This method proved to be effective and fast and all the balance shear keys were cut in time and to their full section.

#### 10.9 Vibrating 150 MSA concrete:

Initially during the trial mixes and during the casting of the test block for the shrinkage study, it was found that the concrete of 150 MSA was not getting vibrated at all. The efforts employed by the usual 40 or 60 mm dia needle vibrators were found inadequate. Then, high frequency internal vibrators of 140 mm dia with powerful in-built electrical motors of 3000 rpm MK 747 make, model FA 250, capable of vibrating at 7500 cycles per minute were specially ordered which turned out to be adequate for vibrating the 150 MSA concrete and the concreting went on very smoothly.

#### 10.10 Summary

After the event of December 1967 earthquake at Koyna with the epicentre near the dam, some of the non-overflow blocks showed considerable distress in the form of major



cracks at the level of a kink both in the downstream and upstream faces. It was necessary to undertake immediate repairs to the dam. These were accomplished through immediate use of prestressing cables to stitch across the cracks developed on NOF faces.

Subsequently strengthening of NOF by concrete backing and buttressing was carried out in 1972 as a permanent measure. After a 6.3 magnitude earthquake in 1993 in the southern part of the state at Killari, the Government of Maharashtra set up a committee for deciding modifications to be carried out in design standards and ascertaining the safety of major and medium completed dams in earthquake prone regions of Maharashtra State. Accordingly, design standards were set and stability for 27 dams was reviewed and it was decided to strengthen 11 dams, which included Koyna Dam spillway. Having a generation of 3300 million units of power every year and catering to the irrigation need of about 50,000 Ha of land, Koyna catchment has a very high precipitation with a reservoir filling success rate of more than 80% over the last 40 years. However, known to be a silent seismic area of more than 200 years, the spurt of earthquakes started from 1963 and so far 1,11,098 shocks of various magnitudes upto a magnitude of 6.5 on Richter scale have been recorded. Therefore, in view of the importance of this project, the energy and irrigation needs of the State and in view of the continued seismic disturbances in the region, protecting this dam against any severe earthquake had become mandatory. At the same time storage augmentation to the tune of 184 Mm<sup>3</sup> was accomplished by providing 1.52 m high movable flaps over the existing radial gates. All these factors earnestly warranted the strengthening of Koyna spillway. It was decided to strengthen Koyna Dam spillway for revised seismic parameters and raised F.R.L.

The task involved designing the section through a series of analyses including dynamic analysis, and judging the efficacy of hydraulic profile through competent model experiments. It also required meticulous planning of construction activities as the entire strengthening work was to be completed within a span of 2 years, the net available time duration being 400 days.

## 11. KRISHNA RAJA SAGARA DAM, KARNATAKA

### 11.1 Introduction

Krishna Raja Sagara dam project is a multi-purpose project formed by the construction of a dam across the Cauvery river. It earned the honors on its completion of being the biggest contemporary dam in Asia and the second biggest in the world after the Aswan dam of Egypt. The dam is situated about 16 km north-west of Mysore city. The idea of construction of a dam across the river Cauvery was first mooted as early as 1870 by the then Chief Engineer Col. Sankey. The dam is named after Krishna Raja Wodeyar IV, the king of Mysore. Sir M Visveswaraiyah, known for his foresight & grand vision had conceived this project. The construction of dam was started in the year November 1911. Storage to an level of +18.3 m was secured in July 1915, +24.4m in the year 1920 and practically completed entirely in the year 1932. The construction was done with manual labour with available local materials. No big machinery for hauling material were used except trolleys for carrying material and power mills for grinding mortars. Gneiss granite with band of Horn blend schist forms the foundation of dam. The catchment area is comprising of hilly and thickly wooded Malnad portion. The dam is amongst the first in the world to use automatic gates and represent the marvel of civil engineering of pre-independent India. The northern edge of the dam is beautified by colorful dancing fountains. The existence of an ornamental terraced garden called Brindavan garden, make it popular picnic spot and tourist attraction. The reservoir ensures a steady supply of water for the generation of power at Shivanasamudram Shimsa power station. Energy dissipation arrangement is provided by waste weir valley protected by pin stone sloping apron with longitudinal and cross walls in between. The view of the dam is shown below in Photograph -1.



Photograph 1: View of the Krishna Raja Sagara dam

The Salient features of the dam are as follows:

Top of Dam	754.32 m
Full Reservoir Level ( FRL)	752.48 m
Maximum Water Level (MWL)	752.48 m
Sill level of irrigation sluices	732.74 m
Sill level of Scouring sluices ( Closed )	718.12 m
Minimum draw down level ( MDDL)	732.74 m
Lowest river bed	714.45 m
Deepest foundation level	709.66 m
Maximum width at level foundation	33.88 m
Height above the lowest river bed	39.87 m
Width at the top	4.12 m
Length at top of the dam	2621 m
Volume of the body of the dam	849600 cum.
Material for dam construction	Locally available granite size stone and random rubble masonry with surkhi mortar
Catchment Area	10,880.63 Sq.km (4201.03 Sq.miles)
Width of River at Dam Site	277.44 meters (910 feet)
Gross Storage Capacity of the Reservoir above the bed of the River	1369.75 M.cum (48,335 Mcft.)
Dead Storage Capacity	124 M Cum.
Historical maximum flood discharge in the river	6035 Cumec (2,13,113 cusecs) in July, 1961.
Maximum discharge capacity provided	9918.50 Cumec (3,50,000 cusec)
Revised design flood estimate	17010 Cumec as approved by CWC
Total No of Gates	173 Nos.
Side slopes 1. Upstream 2. Downstream	Vertical with a chamfering of 1:40 Vertical in the top 3.78 m. varying slopes of 3 in 10 at foundation level.
Maximum water spread area	129.50 sq.km.
Original cost of whole scheme	Rs.9.1 Crores (1932)

## 11.2 Inspection by CWPRS, DSRP, Studies and Repair Methodology

The CWPRS officers visited the dam and submitted their observations as under :

- Sweating on downstream face masonry portions between Ch 1460 to 1850 (photo-3).
- Leaching of pointing mortar at some places
- Springs of water on downstream face at CH 2120 (Photograph -2 & 3)



Photograph- 2



Photograph-3

- Damages in seals of the gates leading to leaking through these seals particularly in gate nos. 1,9,10,12,14,15,19,23,25,28 to 36 of +106' & +103' level sluice gates.
- Peeling off the mortar in masonry joints of apron with pitting on surface
- Distresses on upstream face like deep and wide openings between adjacent masonry rocks and loosened masonry stones.(Photo- 4,5,6)



Photograph- 4



Photograph- 5



Photograph- 6

Following studies were suggested for diagnosing causes of distress.

- Rotary core drilling of 150 mm diameter in masonry portion where
- excessive sweating is observed
- Bore hole videography in the drilled bore holes of 150 mm to assess the status of masonry
- Sonic tomography tests may be undertaken to identify the cavities/ distresses in masonry.

On the basis of the investigation studies, the remedial measures suggested for arresting seepage and strengthening of dam were:

- On the upstream face of the dam the joints between masonry shall be raked and pointed using suitable cementitious mortar.
- Grouting of the dam body to improve the density and strength properties of the masonry.

Studies to devise suitable repair methodology and recommend repair materials for the existing site conditions were entrusted to CWPRS, Pune. The assumptions made in this

regard were:

- The volume of mortar in stone masonry as 30 %
- About 0.3% of mortar in masonry joints might have been lost over years
- The average size of each stone is 30 cm x 30 cm x 200 cm (reference to construction details and available data)
- The average size of masonry joints as 5 cm x 5 cm x 200 cm as estimated from measurements at certain locations of upstream face of dam
- Repacking of about (0.3) x 5 cm x 5 cm x 200 cm volume of lost pointing material will be required per joint.

The repair methodology suggested by CWPRS was:

1. Cleaning of the masonry joints with high water pressure jet to remove loose materials inside
2. Application of a coat of algae fungi removal
3. Drying the cavities by air pressure
4. Fixing grouting nozzles of 12.5 / 6 mm diameter for grouting of cement-sand slurry at places where deep cavities are observed. Nozzles shall be fixed perpendicular to surface.
5. Filling the joints from the base leaving up to 5 cm from surface using cement sand mortar of ratio cement : Sand = 1:3
6. After curing of cement mortar apply recommended bond coat on inside surface of masonry and on the filled cement mortar surface manually.
7. Filling of the rest 5 cm (above the cement mortar) by repair mortar. The filling shall be done by pressing mortar inside and tamping. (refer Figure -1 below)
8. Raising of repair mortar on either side of masonry joint i.e. on rock surface by 2cm and for a thickness of 10-12 mm
9. Curing of pointed area
10. Application of a coat of cementitious sealing material over the pointed surface
11. Grouting of deep cavities by cement slurry after completing of
12. The standard application procedure as per manufacturer of material shall be followed during application

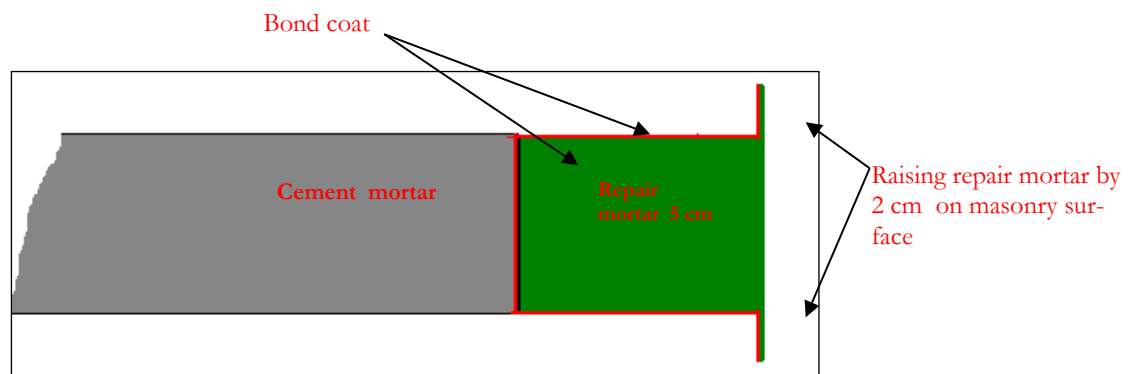
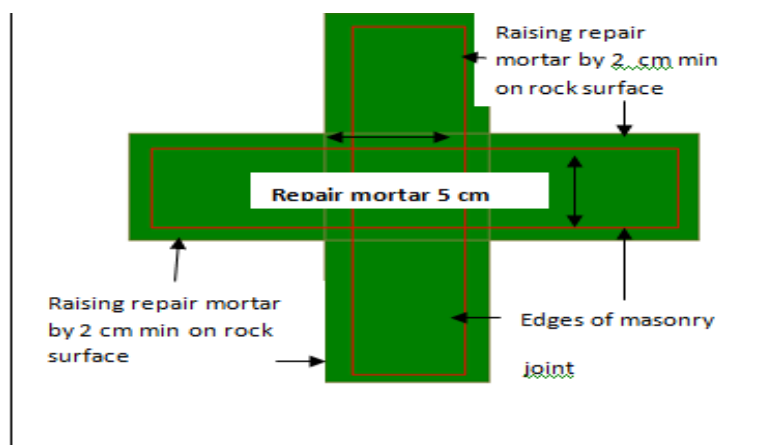

Figure 1: Filling is done by pressing mortar inside and tamping





**Front view of mortar filled surface**

Figure 2:

After studying a number of repair mortars and bonding agents supplied by the project from different manufacturers/ suppliers and verifying their workability for application for typical site conditions of Krishnarajasagara dam, the recommendations on repair mortar and bonding agents of CWPRS were:

*“The repair mortar with bonding agent material namely, PICC :Nicomix 100 + cement and Kelox R 101 M-Kelox H 404 M of M/S Dimple Chemicals & Services Pvt Ltd. Pune is appropriate for use in raking joints in masonry “*

The properties of PICC and the bonding agent vide CWPRS technical note are as under. The UV resistant of PICC mortar was determined by ARAI, Pune and toxicity was studied by National Toxicity Institute, Pune.

#### Properties of PICC

i)	Compressive strength	: 400 to 460 kg/cm <sup>2</sup>
ii)	Tensile strength	: 32 to 35 kg/cm <sup>2</sup>
iii)	Bond strength under shear (Slant cone)	: 50 to 66 kg/cm <sup>2</sup>
iv)	Bond strength with fresh cement mortar with primer at interface	: 13 to 18 kg/cm <sup>2</sup>
v)	Bond strength with rock with primer at interface	: 12 to 19 kg/cm <sup>2</sup>
vi)	Modulus of Elasticity (x10 <sup>5</sup> )	: 2.4 to 3.2 kg/cm <sup>2</sup>
vii)	Abrasion resistance	: 0.42 to 0.44 gm/cm <sup>2</sup>
viii)	Permeability (K)	: <10 <sup>-12</sup> m/s
ix)	UV resistant	: Certification by ARAI
x)	Non Toxic	: Certification by NTC
xi)	Porosity	: <1%(in house)

After obtaining the repair methodology and the recommendations on repair mortar, the rehabilitation methods proposed were discussed with concerned officers of CWPRS for probable difficulties likely to be faced during application and remedies to overcome those, the required quality control measures at site etc. This was also discussed with various experts of Karnataka WRD and with members of Dam safety Review Panel. The stepwise application procedure, the repair methodology as suggested by CWPRS, the cri-



terion for selection of repair mortars was enumerated to World Bank expert to obtain their consent for rehabilitation work

### 11.3 The rehabilitation procedure

The work of executing the job of rehabilitation was awarded to M/S Ferro Concrete Construction India Pvt. Ltd, an Indore based company. The firm have extensive experience in the field of dam rehabilitation. The applications were done as per STANDARD APPLICATION PROCEDURE devised by the manufacturer of PICC mortar. The stepwise application at site is enumerated in following paragraphs.

#### 11.3.1 All loose pointing material in masonry joint was removed using mechanical breakers till hard strata.



#### 11.3.2 The open joints were cleaned by a solution of STERIPURE 100 and water for algae fungi removal and also further protection from it.



#### 11.3.3 The deep cavities of more than 50 mm depth were observed these were filled with cement mortar of ratio 1:3



11.3.4 Primer namely bonding agent was applied on surface of raked joints



11.3.5 The masonry joints were filled by PICC mortar to have a T joint suitably raised over the rock



11.3.6 The PICC mortar was cured by spraying water for 7 days (minimum)



11.3.7 A coat of sealing material, namely NICCOAT PC & KELMER A80 was applied on PICC mortar as water repellent & UV resistant agent



11.3.8 After pointing was completed, wherever deep cavities were identified, these were grouted using cement slurry and admixture.



11.3.9 The repair work was inspected regularly by project officers, consultants, DRIP and world bank consultants



11.3.10 The working personnel were regularly trained for application of PICC by the technical advisors



Photograph- 22



11.3.11 The finished surfaces of KRS dam after pointing are shown below.



An area of about 40000 sq m is treated up to the end of July 2017. The quantities of material consumed for the work up to date are as under:

i) Poly Ironite Ceramic Cementitious mortar (NICOMIX 100)	: 537 ton
ii) Cement	: 313 ton
iii) Bonding agent (KELOX)	: 9.0 ton
iv) NICCOAT PC	: 3.7 ton
v) Kelmer A 80	: 3.0 ton

#### 11.4 Grouting the body of dam

The investigation agencies/organizations viz. CWPRS, the Dam Safety review panel and also the World Bank experts had recommended to take up the grouting of the dam body. However it was suggested to drill cores from each of the block to assess the quality of masonry and to conduct borehole videography and permeability tests before finalizing the grouting pattern.

##### 11.4.1 Cores and Bore Hole Videography

Two bore holes of 150 mm diameter were drilled in the body of the dam by rotary core drilling method in the deep gorge portion and extending for about 3 m in to the foundation rock. The cores recovered were physically inspected to study the conditions of dam body masonry. Bore Hole Videography tests were also conducted in these holes for the entire length of the hole by lowering the bore hole camera to observe and record physical condition of the masonry at all levels.

Though the core samples indicates lime surkhi mortar joints as quite sound and intact, the bore hole videography clearly shows that there are substantial openings in masonry joints at various levels which may lead to seepage of water from reservoir through body of the dam.

##### 11.4.2 Investigation Holes

76 mm (NX size) rotary core holes were drilled at interval of 50 m from top of dam and up to 3 to 4 m in to the foundation rock. Core Samples were extracted to assess the physical condition of the masonry and joints. While drilling water loss tests were conducted at every 6 m stage. The core recovery was in the range of 50 to 65%, the water loss values were quite high ranging between 15 to 29.83 Lugeons in masonry. At few locations there was complete water loss (5 stages). On completion of a hole to its required depth and permeability tests were taken the investigation holes are grouted with neat cement in ascending stage method in 6 m stages. The average grout consumption in investigation holes is 172.38 kg/m and in certain stage it has even gone up to 1331 kg/m.

From the observations of borehole videography, the high Lugeon values of water loss test, high grout intake and acceptance grout consistency of 1:1 ratio clearly indicates substantial openings in the masonry joints and existence of seepage paths inside the dam body. It was opined that if the openings of the masonry joints and seepage paths are not effectively sealed it may lead to de-stability of the dam structure.

In view of the above, the consultants and the experts recommended to grout the dam body as already suggested by CWPRS in their investigation report.

#### 11.4.3 Grouting

On completion of the grouting of investigation holes regular drilling and grouting was taken up in the order of Primary holes, Secondary Holes, Tertiary Holes, Test Holes and Additional Tertiary holes. The sequence and details of grouting are as below:

The row locations are Primary holes at 1.3 m, Secondary holes at 2.8 m, Tertiary holes at 2.05 m and additional holes at 1.67 m from the upstream face. The spacing of holes are Primary 12m c/c, Secondary 6m c/c (between two primary holes), Tertiary 3m c/c (between primary and secondary) and additional holes 1.5 m c/c (between primary and tertiary or between secondary and tertiary). The diameter of the grout holes are 51 to 57 mm with non-coring rotary method of drilling. The grout holes are drilled from top of the dam and about 3 to 4 m in to the foundation rock. The grout holes are drilled and grouted in descending stage method with stage depth of 6 m. Water loss tests were conducted in alternate stages of each grout hole. The grouting has been executed as per IS: 6066 - 1994 with grout consistency of 1:10 (cement : water) and increased gradually to 1:5 to 1:3 to 1:2 to 1:1 depending on intake of grout and buildup of pressure. The grouting pressure applied at 0.15 kg/cm<sup>2</sup> per m depth of hole or limited to 3.5 kg/cm<sup>2</sup>. The grouting was considered as grouted to refusal when the grout intake reaches at the rate of 2 litre/minute at maximum pressure of grouting observed over a period of 10 minutes. Non shrink admixture Cebex 100 was used at 225 gram per bag of cement.

The machineries used for grouting and the grouting process are shown in following photos:

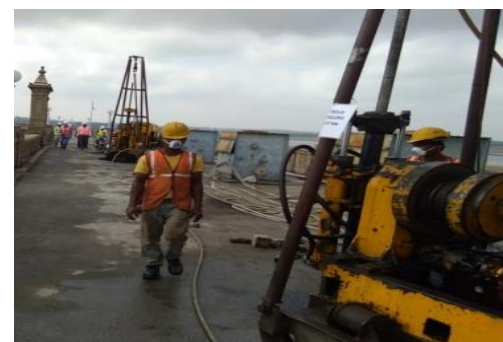

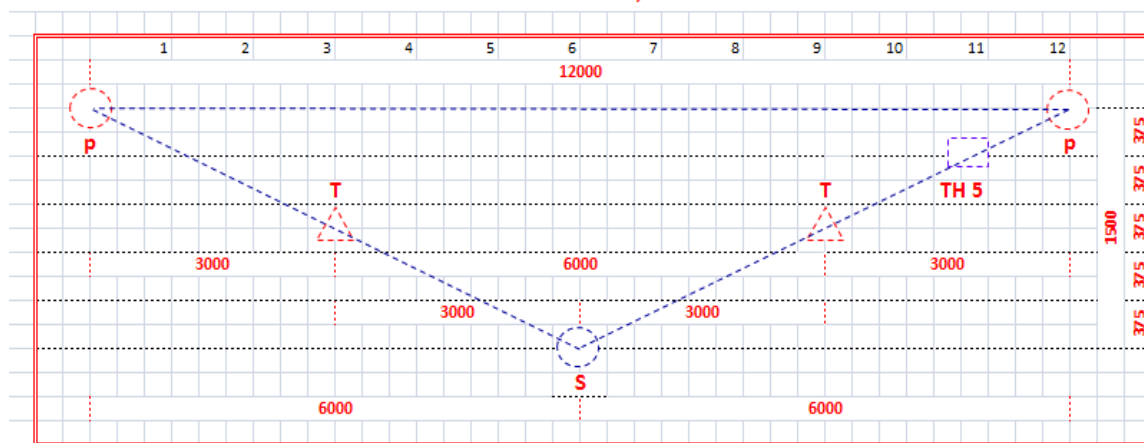
**TEST HOLE COMPARISON WITH ADJACENT PRIMARY, SECONDARY AND TERTIARY HOLES**

HOLE NO.	P 103	T 204	S 102	T 203	TH 5	P 102
CHAINAGE	1967	1964	1961	1958	1956.5	1955
LUGEON						
1m to 7m	22.66		13.91	12.08		21.00
7m to 13m		14.08			7.00	
13m to 19m	23.54		13.40	13.40	13.50	
19m to 25m		12.23			6.50	22.77
25m to 32m			14.71	14.71	4.85	
GROUT IN Kgs						
1m to 7m	1345	520	441	540	150	441
7m to 13m	1231	460	520	588	370	520
13m to 19m	1284	655	1549	440	520	1549
19m to 25m	1358	460	970	561	290	970
25m to 32m	1345	540	1258	635	360	1258
AVERAGE GROUT Kgs/m	218.77	78.66	148.06	83.76	54.52	148.06

In all about 467 holes were drilled for grouting which includes 28 nos of Investigation holes, 106 nos of primary holes, 108 nos of Secondary holes, 220 nos of Tertiary holes and 5 nos of test holes. The total grout consumption is 2289.34 MT for an average consumption of 121.88 Kgs/m.

#### 11.5 Hydro-Mechanical works

The dam has in all 172 sluices of different sizes at various levels as under:

Sl. No.	Sluice	Sill Level / Location	Gate Details
I	Scouring Sluices		
		(a) RL 3.66 m (+12 feet above river bed)	8 Nos. (Now plugged Permanently since May 2007)
		(b) RL 15.24 m (+ 50 feet above river bed)	3 Nos. of 1.83 m x 4.54 m (6' x 15')
II	Turbine Sluices		
		RL 16.15 m (+ 53 feet above river bed)	4 Nos. Pipes of 1.83 m diameter (6') (Now plugged)
III	Irrigation Sluices		
1	Right bank low level canal	RL 18.29 m (+ 60 feet) above river bed	1 No. of 1.83 m x 2.44 m (6' x 8')
2	Left bank canal	RL 18.29 m (+ 60 feet)	3 Nos. of 1.83 m x 3.66 m



Sl. No.	Sluice	Sill Level / Location	Gate Details
	(VC canal)	above river bed	(6' x 12')
3	Right bank canal	RL 18.29 m (+ 60 feet) above river bed	2 Nos. of 3.50 m x 3.50 m (11.5' x 11.5')
IV	Sluices for Flood Disposal		
(a)		RL 24.38 m (+80 feet) above river bed	16 Nos. of 3.00 m x 6.00 m(10' x 20')
(b)		RL 31.39 m (+103 feet) above river bed (Bottom tier)	48 Nos. of 3.00m x 2.44 m (10' x 8')
(c)		RL 32.31 m (+106 feet) above river bed	40 Nos. of 2.66 m x 3.66 m (8' x 12')
(d)		RL 34.74 m (+114 feet) above river bed (Upper tier)	48 Nos. of 3.00 m x 3.00 m(10' x 10')

The gates of sluices at +50', +60' & +80' levels were replaced /repaired earlier. Under the DRIP gates at +106', +103' & +114' levels are being replaced. The cast iron gates installed in these sluices have been designed & manufactured by M/S Ransomes & Rapier Ltd, England. These gates comprise mainly of the sill, lintel & side groove embedment with stanchions frames (all cast iron), cast iron body gates, cast iron roller path, roller frames & hoisting machinery/gantry.

The gate and the embedment design adopted is such that the gates generally remain loosely held in the grooves instead of a tight fit. The gates are to be operated under varying conditions of partial gate openings for passing the desired discharge. The reservoir being quite huge, the wind action generates water waves which frequently hit the dam and gate installations causing bumping of the gates in the grooves. These gates were therefore, experiencing vibrations & bumping phenomena in a regular manner due to wave action especially when the gates remain in partial opening condition resulting in damages/cracking of the gates.

These gates manufactured from cast iron material have undergone damages such as cracks and even getting broken which were being repaired by splicing the damaged parts of the gates and were being reused. The embedded parts especially the stanchion plates which seal the gates by abutting together were also found broken and missing at many locations.

The skin plate of almost all gates had developed uniform rusting with general pitting and scaling.

Sealing against water leakage is achieved by means of staunching arrangement which provides two brass surfaces to come in contact once the gate is fully closed. However, the action is not automatic and in the present case the gate plates are pushed forward using screw jacks to abut against embedments. The metallic seals are never expected to give water tight joint (design shortcoming) and it seems water tightness was not imperative all these years as there are numerous anicuts on downstream. But the situation has been aggravated due to damage/loss of brass beading; both on staunching plates & embedments leading to profuse leakages. Divers are normally deployed to pack the gaps between staunching plates and embedments with jute/gunny bags to minimize leakage but are temporary measure. Further, the operating mechanism by means of screw jacks is not user friendly.

Further all the gates at +114' level are presently incorporated +114' level gates: These gates are presently inoperative due to non-functioning of float system. The automatic hoisting arrangement is in dilapidated state and it seems that no efforts have been made in the past to make them functional. These gates have not been operated for last many years. The restoration of automatic float system was not recommended as its functional reliability cannot be ensured.

1. The Existing Status of the Gates being taken up for replacement under DRIP is as under:

S. No	Gate Location	Total No of Gates	Non-Functional Gates	
			Identification	Qty.
1	+ 103'	48	1, 10, 12, 13, 19, 22, 29, 32, and 33.	9 Nos.
	+ 106'	40	1, 3, 5, 7, 8, 9, 14, 15, 19, 21, 24, 25, 28, 30, 31, 32, 33, 34, 36, 37, 42, and 48	22 Nos.
	+ 114'	48	1 to 48	

#### 11.5.1 Typical details of Existing Cast Iron Gates and Embedded Parts

Some photographs taken during site inspections in respect of the gates at +106', +103', & +114' are as under:

Some photographs taken during site inspections in respect of the gates at +106', +103', & +114' are as under:-

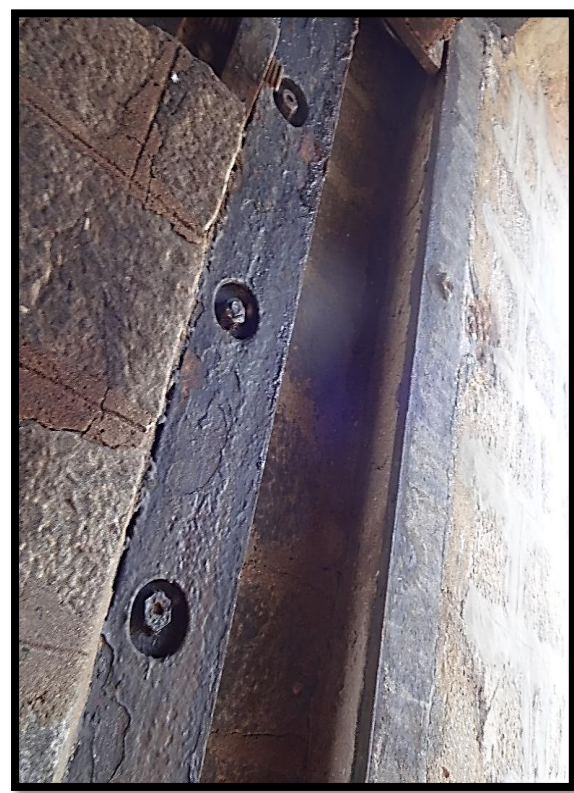

Existing gates groove and embedded parts for +106' gates





+103' gate and embedded parts - looking from d/s side.



+103' sluice gates in partial open condition with +114' gate in the background - looking from d/s side.





Existing +114' gates presently welded in position. The wheels and the grooved wheel tracks on the right side are visible. Similar track exists on left side also.



Existing +114' gates in hanging position over +103' sluices.





+103' & +114' sluices openings looking from d/s side. The counter weight is visible in suspended condition next to +114' sluice (to be removed, as it may not allow proper aeration of water nappe discharging from +114' gates.)

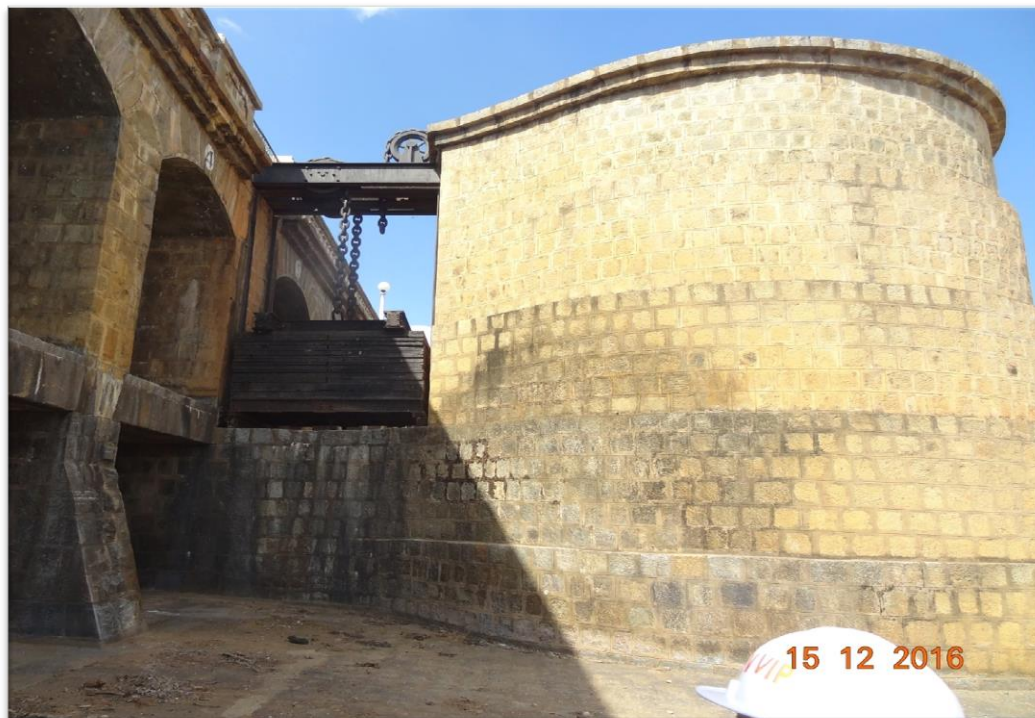

Downstream view of +103' & +114' sluice & wet well with counter weight.

### 11.5.2 Modification Planned in the Gates & Hoists arrangements

It was decided to carry out the modifications with least disturbance to the existing 100 year old civil structure/masonry. The drawings for tendering purpose are attached.

The existing embedded parts are not proposed to be removed & will be used as such with structural steel/stainless steel plates welded to them suitably. The new gates will be generally designed as per the provision in various Bureau of Indian Standard Codes. All proposed provisions can be seen from the drawings. Compact Hoists as per IS: 3938 are proposed for the gates. SCADA system for gates operation is also planned.



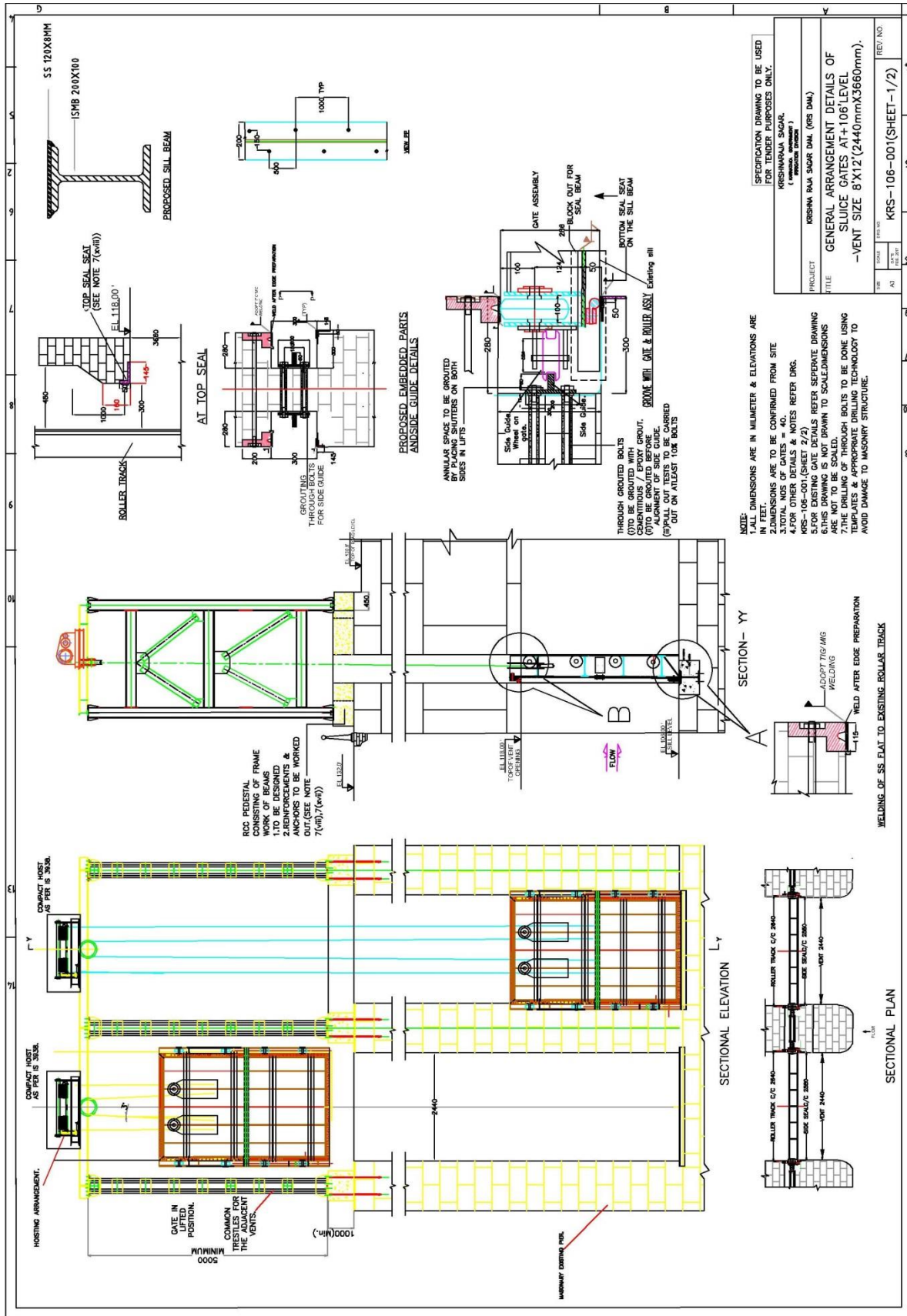

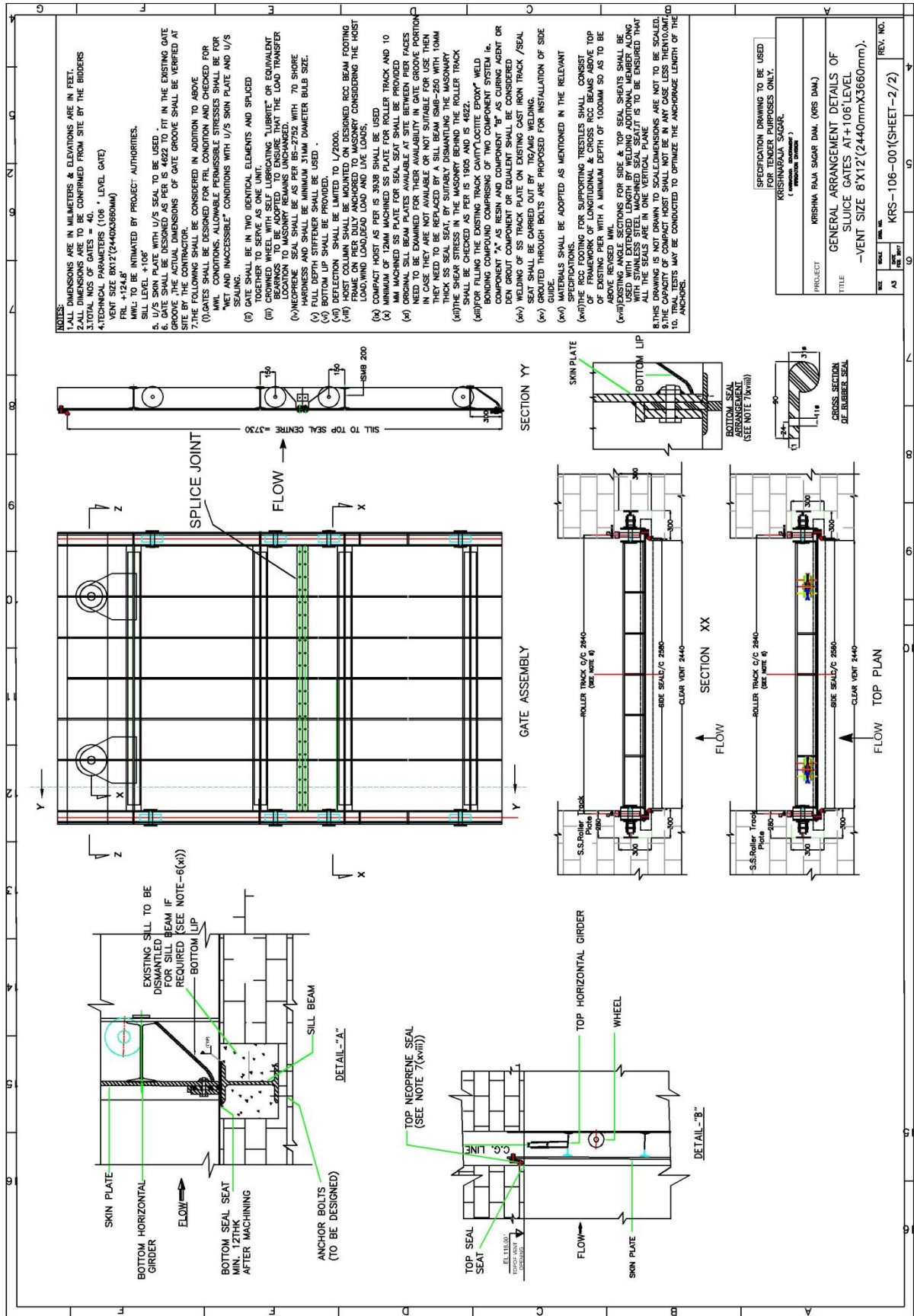

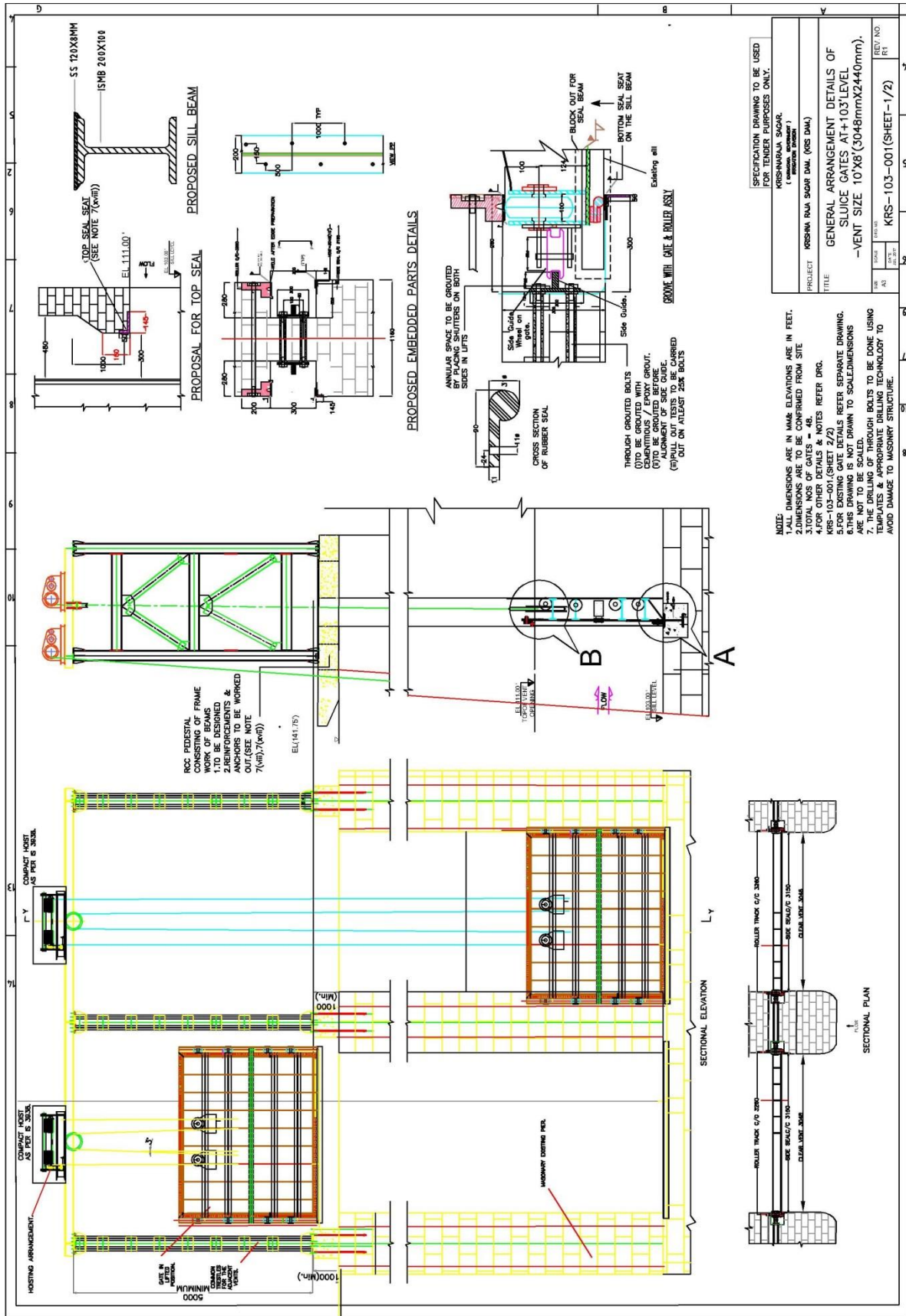



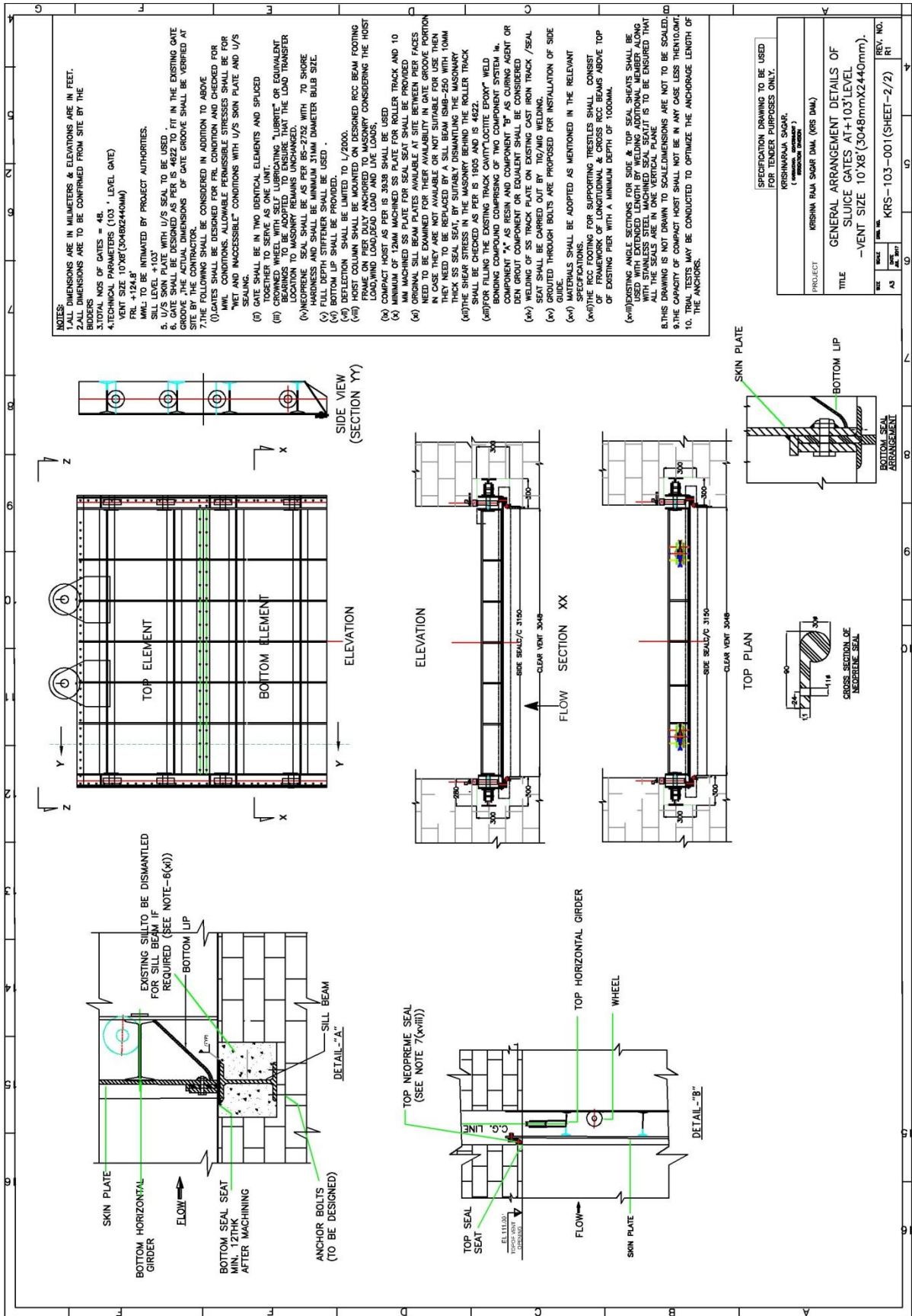

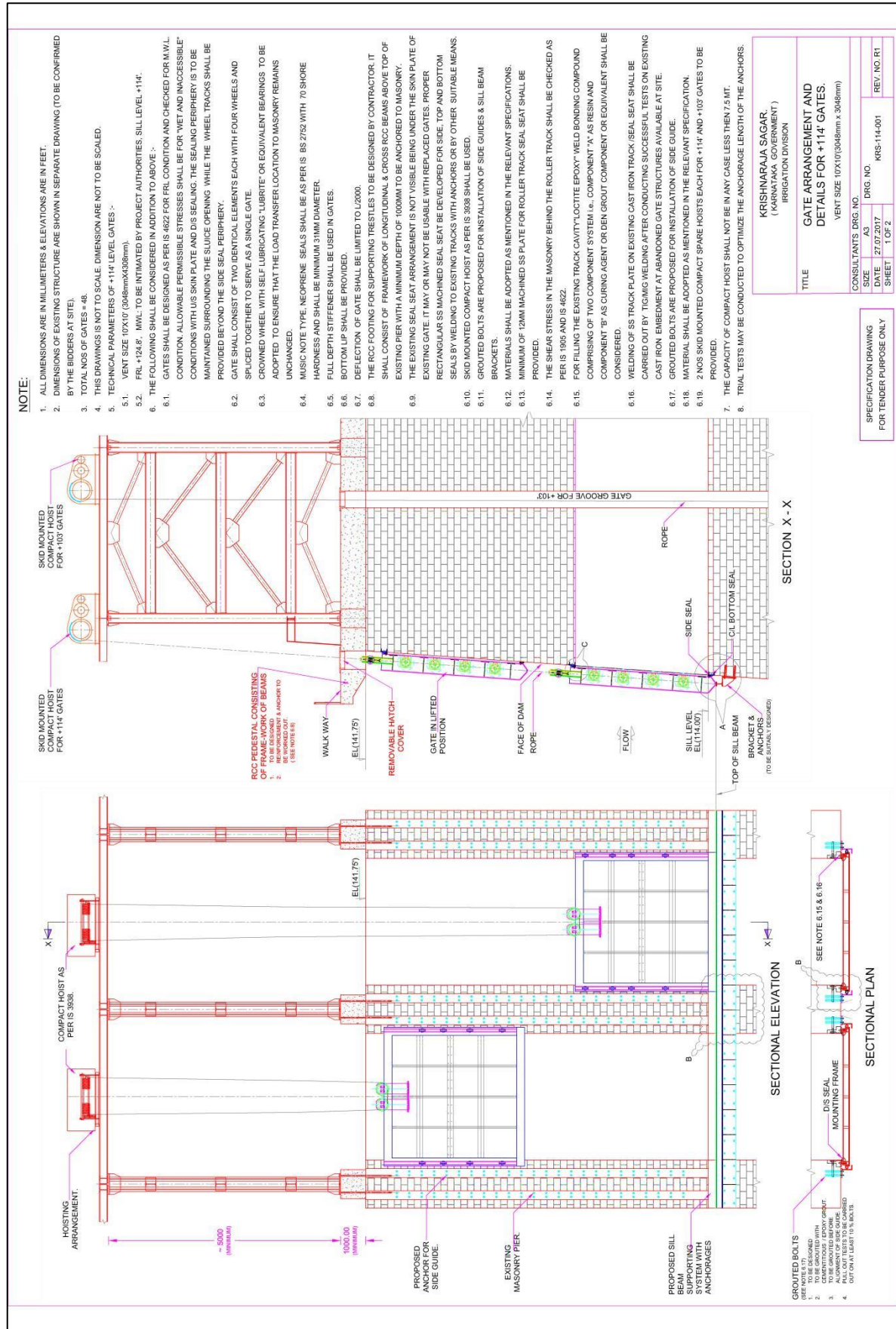



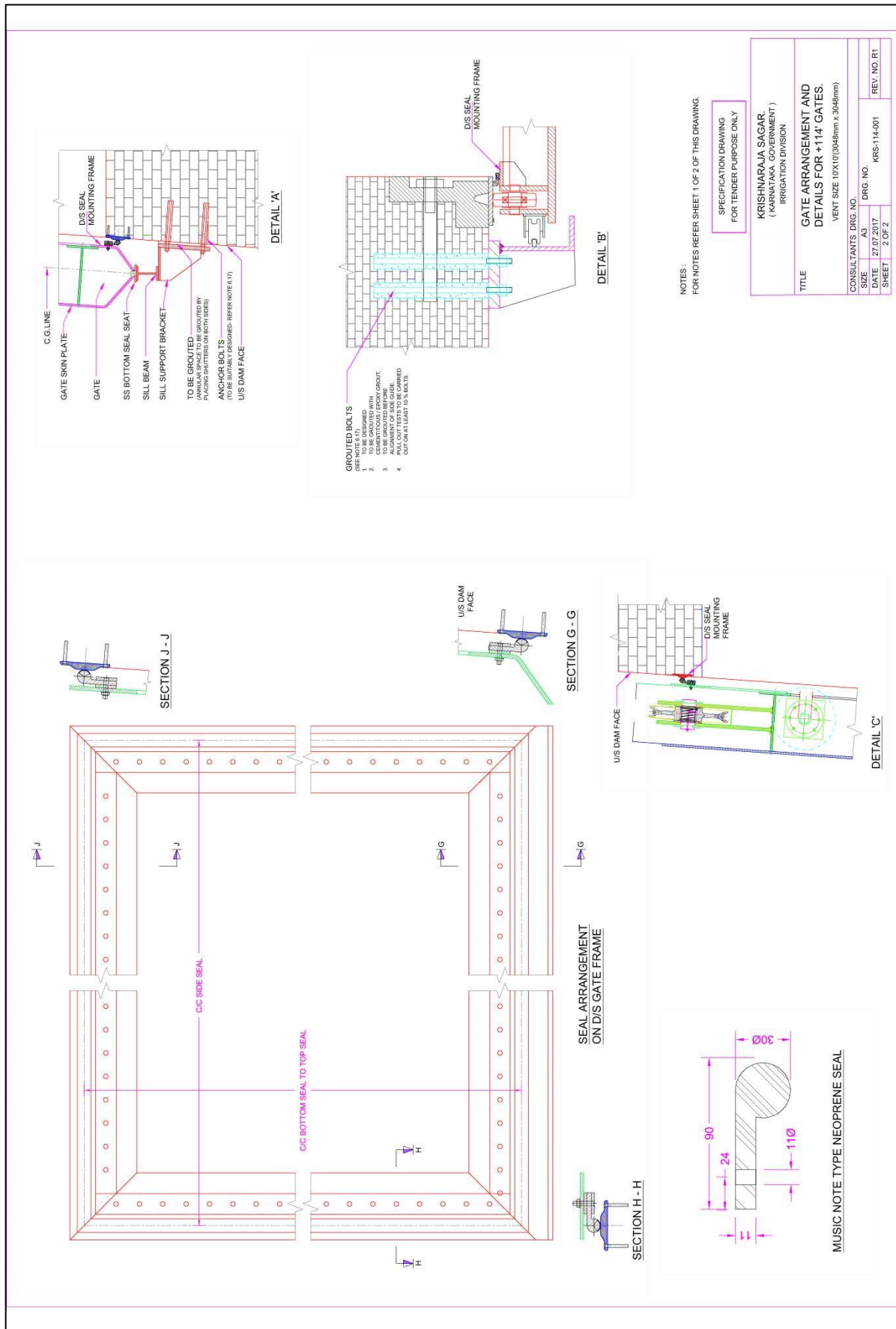

This page has been left blank intentionally.

## **APPENDIX B – GLOSSARY OF TERMS FOR DAM REHABILITATION**

This page has been left blank intentionally.

## Glossary of Terms for Dam Rehabilitation

The purpose of this glossary is to define a common vocabulary of dam rehabilitation terms for use within and among Central and State Government agencies, dam owners and operators, consulting engineers, and construction contractors. Terms have been included that are generic and apply to all dams, regardless of size, owner, or location.

**Abutment** – The part of the valley side against which the dam is constructed. The left and right abutments of a dam are defined with the observer looking downstream from the dam.

**ALARP** – The acronym stands for “as low as reasonably practicable,” and is a term often used in the regulation and management of safety-critical and safety-involved systems. The ALARP principle is that the residual risk shall be reduced as far as reasonably practicable.

**Appurtenant work** – Structures associated with the dam including the following:

- a) Spillways, either in the dam or separate therefrom;
- b) Reservoir and its rim;
- c) Low-level outlet works and water conduits such as tunnels, pipelines or penstocks, either through the dam or its abutments or reservoir rim;
- d) Hydro-mechanical equipment including gates, valves, hoists, and elevators;
- e) Energy dissipation and river training works; and
- f) Other associated structures that act integrally with the dam body.

**Auxiliary spillway** – Any secondary spillway that is designed to be infrequently operated, in anticipation of some degree of structural damage or erosion to the spillway that would occur during operation.

**Barrage** – While the term barrage is borrowed from the French word meaning “dam” in general, its usage in English refers to a type of low-head, dam that consists of many large gates that can be opened or closed to control the amount of water passing through the structure, and thus regulate and stabilize river water elevation upstream

for use diverting flow for irrigation and other purposes.

**Berm** – A horizontal part of the slope of an embankment or cutting.

**Bill of quantities** – A means of listing and quantifying the volume and type of work in a piece of construction so that its cost or value can be determined.

**Boil** – A disruption of the soil surface caused by water discharging from below the surface. Eroded soil may be deposited in the form of a ring (miniature volcano) around the disruption.

**Breach** – An excavation or opening, either controlled or a result of a failure of the dam, through a dam or spillway that is capable of completely draining the reservoir down to the approximate original topography, so the dam will no longer impound water, or partially draining the reservoir to lower impounding capacity. An uncontrolled breach is associated with the partial or total failure of the dam.

**Breach analysis** – The determination of the uncontrolled release of water from a dam (magnitude, duration, and location), using accepted engineering practice, to evaluate downstream hazard potential.

**Breach inundation area** – An area that would be flooded because of a dam failure.

**Chimney drain** – A vertical or inclined layer of permeable material in an embankment to control drainage of the embankment fill.

**Cofferdam** – A temporary structure that encloses all or part of the construction area so that work can proceed in dry conditions. A diversion cofferdam diverts a stream into a pipe, channel, tunnel, or another watercourse.



**Compaction** – Mechanical action that increases soil density by reducing voids.

**Concrete lift** – The vertical distance between successive horizontal construction joints.

**Conduit** – A closed channel to convey water through, around, or under a dam.

**Construction joint** – The interface between two successive placements or pours of concrete where bond, and not permanent separation, is intended.

**Construction** – Building a proposed dam and appurtenant structures capable of storing water.

**Contact grouting** – Filling, with cement grout, any voids existing at the contact of two zones of dissimilar materials, i.e., between a concrete tunnel lining and the surrounding rock.

**Core wall** – A wall built of impervious material, usually of concrete or asphaltic concrete in the body of an embankment dam to prevent seepage.

**Cost plus, target cost** – Names for contractual philosophies, reflecting how much the contractor is paid in relation to his costs.

**Creep** – A process of deformation that occurs in many materials where the load is applied over an extended period.

**Cutoff trench** – A foundation excavation later to be filled with impervious material to limit seepage beneath a dam.

**Cutoff wall** – A wall of impervious material usually of concrete, asphaltic concrete, or steel sheet piling constructed in the foundation and abutments to reduce seepage beneath and next to the dam.

**Dam** – Any artificial barrier including appurtenant works constructed across rivers or tributaries thereof with a view to impound or divert water; includes barrage, weir and similar water impounding structures but does not include water conveyance structures such as canal, aqueduct and navigation channel and flow regulation structures such as flood embankment, dike and guide bund.

**Dam failure** – Failures in the structures or operation of a dam which may lead to an uncontrolled release of impounded water resulting in downstream flooding affecting the life and property of the people.

**Dam incident** – All problems occurring at a dam that have not degraded into ‘dam failure’ and including the following:

- a) Structural damage to the dam and appurtenant works;
- b) unusual readings of instruments in the dam;
- c) unusual seepage or leakage through the dam body;
- d) change in the seepage or leakage regime;
- e) boiling or artesian conditions noticed below an earth dam;
- f) stoppage or reduction in seepage or leakage from the foundation or body of the dam into any of the galleries, for dams with such galleries;
- g) malfunctioning or inappropriate operation of gates;
- h) occurrence of any flood, the peak of which exceeds the available flood discharge capacity or 70% of the approved design flood;
- i) occurrence of a flood, which resulted in encroachment on the available freeboard, or the adopted design freeboard;
- j) erosion in the near vicinity, up to five hundred meters, downstream of the spillway, waste weir, etc.; and
- k) any other event that prudence suggests would have a significant unfavorable impact on dam safety.

**Dam inspection** – On site examination of all components of dam and its appurtenances by one or more persons trained in this respect and includes inspection of non-overflow section, spillways, abutments, stilling basin, piers, bridge, downstream toe, drainage galleries, operation of mechanical systems (including gates and its components, drive units, cranes), interior of outlet conduits, instrumentation records and record-keeping arrangements of instruments.

**Dam owner** – The Central Government or a State Government or public sector undertaking or local authority or company and any or all such persons or organizations, who own, control, operate or maintain a specified dam.

**Dam safety** – The practice of ensuring the integrity and viability of dams such that they do not present unacceptable risks to the public, property, and the environment. It requires the collective application of engineering principles and experience, and a philosophy of risk management that recognizes that a dam is a structure whose safe function is not explicitly determined by its original design and construction. It also includes all actions taken to predict deficiencies and consequences related to the failure and to document, publicize, and reduce, eliminate, or remediate to the extent possible, any unacceptable risks.

**Densification** – A means of improving the strength of soil by making it denser, usually by physical compaction.

**Design and Construct** – A form of contract in which the contractor undertakes both the design and the construction of the work.

**Design water level** – The highest water elevation, including the flood surcharge, that a dam is designed to withstand.

**Design wind** – The most severe wind that is possible at a reservoir for generating wind set-up and run-up. The determination will include the results of meteorological studies that combine wind velocity, duration, direction and seasonal distribution characteristics in a realistic manner.

**Diaphragm wall** – A cutoff wall of flexible concrete constructed in a trench cut through an embankment or the foundation.

**Diversion dam** – A dam built to divert water from a waterway or stream into a different watercourse.

**Earth-fill dam** – An embankment dam in which more than 50% of the total volume is formed of compacted earth layers.

**Effective crest of the dam** – The elevation of the lowest point on the crest (top) of the dam, excluding spillways.

**Embankment dam** – Any dam constructed of excavated natural materials, such as both earth-fill and rock-fill dams, or of industrial waste materials, such as a tailings dam.

**Embankment zone** – An area or part of an embankment dam constructed using similar materials and similar construction and compaction methods throughout.

**Emergency repairs** – Any repairs that are temporary in nature and that are necessary to preserve the integrity of the dam and prevent a failure of the dam.

**Emergency spillway** – An auxiliary spillway designed to pass a large, but infrequent, volume of flood flow, with a crest elevation higher than the principal spillway or normal operating level.

**Extensometer** – An instrument used to detect, usually small, movements of a structure or a mass of rock or soil.

**Failure mode** – A potential failure mode is a physically plausible process for dam failure resulting from an existing inadequacy or defect related to a natural foundation condition, the dam or appurtenant structures design, the construction, the materials incorporated, the operations and maintenance, or aging process, which can lead to an uncontrolled release of the reservoir.

**Fetch** – The-straight-line distance across a body of water subject to wind forces. The fetch is one of the factors used in calculating wave heights in a reservoir.

**Filter** – One or more layers of granular material graded (either naturally or by selection) so as to allow seepage through or within the layers while preventing the migration of material from adjacent zones.

**Flap gate** – A gate hinged along one edge, usually either the top or bottom edge. Examples of bottom-hinged flap gates are tilting gates, and fish belly gates so called from their shape in cross section.

**Flashboards** – Structural members of timber, concrete, or steel placed in channels or on the crest of a spillway to raise the reservoir water level but intended to be quickly removed, tripped, or fail in case of a flood.

**Flip bucket** – An energy dissipater found at the downstream end of a spillway and shaped so that water flowing at a high velocity is deflected upwards in a trajectory away from the foundation of the spillway.

**Flood hydrograph** – A graph showing, for a given point on a stream, the discharge, height, or another characteristic of a flood with respect to time.

**Freeboard** – Vertical distance between a specified stillwater (or other) reservoir surface elevation and the top of the dam, without camber.

**Gabion** – Rectangular-shaped baskets or mattresses fabricated from wire mesh, filled with rock, and assembled to form overflow weirs, hydraulic drops, and overtopping protection for small embankment dams. Gabion baskets are stacked in a stair-stepped fashion, while mattresses are placed parallel to a slope. Gabions have advantages over loose riprap because of their modularity and rock confinement properties, thus giving erosion protection with less rock and with smaller rock sizes than loose riprap.

**Gallery** – A passageway in the body of a dam used for inspection, foundation grouting, and/or drainage.

**Gate** – A movable water barrier for the control of water.

**Geomembrane** – An impermeable geosynthetic composed of one or more synthetic sheets.

**Geosynthetic** – A planar product manufactured from a polymeric material used with soil, rock, earth, or other geotechnical engineering related material as an integral part of a project, structure, or system.

**Geotextile** – Any fabric or textile (natural or synthetic) when used as an engineering material in conjunction with soil, foundations, or rock. Geotextiles have the follow-

ing uses: drainage, filtration, separation of materials, reinforcement, moisture barriers, and erosion protection.

**Gravity dam** – A dam constructed of concrete and/or masonry that relies on its weight and internal strength for stability.

**Grout** – A fluidized material that is injected into soil, rock, concrete, or other construction material to seal openings and to lower the permeability and/or provide additional structural strength. There are four major types of grouting materials: chemical; cement; clay; and bitumen.

**Grout blanket** – An area of the foundation systematically grouted to a uniform shallow depth.

**Grout cap** – A concrete filled trench or pad encompassing all grout lines constructed to impede surface leakage and to provide anchorage for grout connections.

**Grout curtain** – One or more zones, usually thin, in the foundation into which grout is injected to reduce seepage under or around a dam.

**Hazard potential** – The possible adverse incremental consequences that result from the release of water or stored contents because of failure or incorrect operation of the dam or appurtenances. Impacts may be for a defined area downstream of a dam from flood waters released through spillways and outlet works of the dam or waters released by partial or complete failure of the dam. There may also be impacts for an area upstream of the dam from effects of backwater flooding or landslides around the reservoir perimeter.

**Hazard potential classification** – A measure of the potential for loss of life, property damage, or economic impact in the area downstream of the dam in case of a failure or malfunction of the dam or appurtenant structures. The hazard classification does not represent the physical condition of the dam.

**HAZOP** – A method of assessing, and by so doing, reducing the hazards associated

with a process, usually in the petrochemical or related industries.

**Height of dam** – The difference in elevation between the natural bed of the watercourse or the lowest point on the downstream toe of the dam, whichever is lower, and the effective crest of the dam.

**Hydraulic fracturing** – Hydraulic fracturing in soils is a tensile parting that is created because of increased fluid pressure. Initiation and/or propagation cracks in the core sections of earthen dams because of hydraulic fracturing affect adversely structural safety of the dams.

**Hydraulic gradient** – The change in total hydraulic pressure per unit distance of flow.

**Hydrology** – One of the earth sciences that encompasses the natural occurrence, distribution, movement, and properties of the waters of the earth and their environmental relationships.

**Hydrometeorology** – The study of the atmospheric and land-surface phases of the hydrologic cycle with emphasis on the interrelationships involved.

**Hydrostatic pressure** – The pressure exerted by water at rest.

**Inclinometer** – An instrument, usually consisting of a metal or plastic casing inserted in a drill hole and a sensitive monitor either lowered into the casing or fixed within the casing. The inclinometer measures the casing's inclination to the vertical at different points. The system may be used to measure settlement.

**Inflow design flood** – The flood hydrograph used in the design of a dam and its appurtenant works particularly for sizing the spillway and outlet works and for determining maximum storage, the height of the dam, and freeboard requirements.

**Instrumentation** – An arrangement of devices installed into or near dams that enable measurements that can be used to evaluate the structural behavior and performance parameters of the structure.

**Internal erosion** – A general term used to describe all the various erosional processes where water moves internally through or adjacent to the soil zones of embankment dams and foundation, except for the specific process referred to as *backward erosion piping*. The term internal erosion is used in place of a variety of terms that have been used to describe various erosional processes, such as scour, suffusion, concentrated leak piping, and others.

**Inundation map** – A map showing areas that would be affected by flooding from releases from a dam's reservoir. The flooding may be from either controlled or uncontrolled releases or because of a dam failure. A series of maps for a dam could show the incremental areas flooded by larger flood releases. For breach analyzes, this map should also show the time to flood arrival, and maximum water-surface elevations and flow rates.

**Jet grouting** – A system of grouting in which the existing foundation material is mixed in situ with cementitious materials to stabilize the foundation, or it improve its water-tightness.

**Karstic** – An adjective to describe a limestone rock mass in which large openings have been caused over geological time by ground water dissolving the rock.

**Large dam** – A dam that is above 15 meters in height, measured from the lowest part of the general foundation area to the top of dam; or a dam between 10 15 meters in height and that satisfies at least one of the following, namely

- a) The length of crest is not less than 500 meters;
- b) The capacity of the reservoir formed by the dam is not less than one million cubic meters;
- c) The maximum flood discharge dealt with by the dam is not less than 2000 cubic meters per second;
- d) The dam has particularly difficult foundation problems; or
- e) The dam is of unusual design.

**Liquefaction** – A condition whereby soil undergoes continued deformation at a constant low residual stress or with low residual resistance, because of the buildup and maintenance of high pore-water pressures, which reduces the effective confining pressure to a very low value. Pore pressure buildup leading to liquefaction may be due either to static or cyclic stress applications, and the possibility of its occurrence will depend on the void ratio or relative density of a cohesionless soil and the confining pressure.

**Loss of life** – Human fatalities that would result from a failure of the dam, without considering the mitigation of loss of life that could occur with evacuation or other emergency actions.

**Low-level outlet (bottom outlet)** – An opening at a low level from a reservoir used for emptying or for scouring sediment and sometimes for irrigation releases.

**Maintenance** – Those tasks that are generally recurring and are necessary to keep the dam and appurtenant structures in a sound condition and free from defect or damage that could hinder the dam's functions as designed, including adjacent areas that also could affect the function and operation of the dam.

**Maintenance inspection** – Visual inspection of the dam and appurtenant structures by the owner or owner's representative to detect apparent signs of deterioration, other deficiencies, or any other areas of concern.

**Masonry dam** – Any dam constructed mainly of stone, brick, or concrete blocks pointed with mortar. A dam having only a masonry facing should not be referred to as a masonry dam.

**Maximum storage capacity** – The volume, in millions of cubic meters ( $Mm^3$ ), of the impoundment created by the dam at the effective crest of the dam; only water that can be stored above natural ground level or that could be released by failure of the dam is considered in assessing the storage volume; the maximum storage capacity may

decrease over time because of sedimentation, or increase if the reservoir is dredged.

**Normal storage capacity** – The volume, in millions of cubic meters ( $Mm^3$ ), of the impoundment created by the dam at the lowest uncontrolled spillway crest elevation, or at the maximum elevation of the reservoir at the normal (non-flooding) operating level.

**Outlet** – A conduit or pipe controlled by a gate or valve, or a siphon, that is used to release impounded water from the reservoir.

**Outlet gate** – A gate controlling the flow of water through a reservoir outlet.

**Outlet works** – A dam appurtenance that provides release of water (generally controlled) from a reservoir.

**Parapet wall** – A solid wall built along the top of a dam (upstream or downstream edge) used for ornamentation, for the safety of vehicles and pedestrians, or to prevent overtopping caused by wave runup.

**Peak flow** – The maximum instantaneous discharge that occurs during a flood. It is coincident with the peak of a flood hydrograph.

**Penstock** – A pressurized pipeline or shaft between the reservoir and hydraulic machinery.

**Phreatic surface** – The free surface of water seeping at atmospheric pressure through soil or rock.

**Piezometer** – An instrument used to measure water levels or pore water pressures in embankments, foundations, abutments, soil, rock, or concrete.

**Piping** – The progressive development of internal erosion by seepage.

**Plunge pool** – A natural or artificially created pool that dissipates the energy of free falling water.

**Post-tensioned anchors** – A system of anchored stressed steel tendons or bars within or attached to a structure to provide structural support.



**Pre-stressed structure** – A structure containing elements that have been pre-loaded with stressed steel tendons, bars or jacks.

**Pressure relief pipes** – Pipes used to relieve uplift or pore water pressure in a dam foundation or in the dam structure.

**Probable Maximum Flood** – The flood that may be expected from the most severe combination of critical meteorological and hydrologic conditions that are possible in the drainage basin under study.

**Probable Maximum Precipitation** – Theoretically, the greatest depth of precipitation for a given duration that is physically possible over a given size storm area at a particular geographical location during a certain time of the year.

**Principal spillway** – The primary or initial spillway engaged during a rainfall-runoff event that is designed to pass normal flows.

**Proposed dam** – Any dam not yet under construction.

**Radial gate** – A gate with a curved upstream plate and radial arms hinged to piers or other supporting structure. Also known as a Tainter gate.

**Rehabilitation** – Work that aims to restore the service life of a structure, as opposed to maintenance, which seeks to restore the status quo, and upgrading whose purpose is to maximize the performance within the physical limits of the structure.

**Repairs** – Any work done on a dam that may affect the integrity, safety, and operation of the dam.

**Reservoir** – Any water spread that contains impounded water.

**Reservoir Storage** – The retention of water or delay of runoff in a reservoir either by the planned operation, as in a reservoir, or by temporary filling in the progression of a flood wave. Specific types of storage in reservoirs are defined as follows:

- a) Active storage – The volume of the reservoir that is available for some use such as power generation, irrigation,

flood control, water supply, etc. The bottom elevation is the minimum operating level.

- b) Dead storage – The storage that lies below the invert of the lowest outlet and that, therefore, cannot readily be withdrawn from the reservoir.
- c) Flood surcharge – The storage volume between the top of the active storage and the design water level.
- d) Inactive storage – The storage volume of a reservoir between the crest of the invert of the lowest outlet and the minimum operating level.
- e) Live storage – The sum of the active and the inactive storage.
- f) Reservoir capacity – The sum of the dead and live storage of the reservoir.
- g) Surcharge – The volume or space in a reservoir between the controlled retention water level and the highest water level. Flood surcharge cannot be retained in the reservoir but will flow out of the reservoir until the controlled retention water level is reached.

**Riprap** – A layer of large rock, precast blocks, bags of cement, or other suitable material, placed on an embankment or along a watercourse as protection against wave action, erosion, or scour.

**Risk analysis** – A procedure to identify and quantify risks by establishing potential failure modes, providing numerical estimates of the likelihood of an event in a specified time period, and estimating the magnitude of the consequences. The risk analysis should include all potential events that would cause an unintentional release of stored water from the reservoir.

**Risk assessment** – The process of deciding whether existing risks are tolerable and present risk control measures are adequate and, if not, whether alternative risk control measures are justified. Risk assessment incorporates the risk analysis and risk evaluation phases.

**Risk management** – A structured approach to understanding the nature of the hazards posed by the design, construction or operation of project works. The organization of the decisions made in the light of the perceived hazards.

**Rock anchor** – A steel rod or cable placed in a hole drilled in rock, held in position by grout, mechanical means, or both. In principle, the same as a rock bolt, but usually the rock anchor is more than 4 meters long.

**Rock bolt** – A tensioned reinforcement element consisting of a steel rod, a mechanical or grouted anchorage, and a plate and nut for tensioning or for retaining tension applied by direct pull or by torquing.

**Rock reinforcement** – The placement of rock bolts, un-tensioned rock dowels, prestressed rock anchors, or wire tendons in a rock mass to reinforce and mobilize the rock's natural competency to support itself.

**Rockfill dam** – An embankment dam in which more than 50% of the total volume is composed of compacted or dumped cobbles, boulders, rock fragments, or quarried rock larger than 75-millimeter size.

**Roller compacted concrete dam** – A concrete gravity dam constructed using a dry mix concrete transported by conventional construction equipment and compacted by rolling, usually with vibratory rollers.

**Rubble dam** – A stone masonry dam in which the stones are not shaped or coursed.

**Saddle dam (or dike)** – A subsidiary dam of any type constructed across a saddle or low point on the perimeter of a reservoir.

**Scour** – The loss of material occurring at an erosional surface, where a concentrated flow is found, such as a crack in a dam or the dam/foundation contact. Continued flow causes the erosion to progress, creating a larger and larger eroded area.

**Seepage** – The internal movement of water that may take place through a dam, the foundation or the abutments, often emerging at the ground level lower down the slope.

**Seiche** – An oscillating wave in a reservoir caused by a landslide into the reservoir or earthquake-induced ground accelerations or fault offset or meteorological event.

**Settlement** – The vertical downward movement of a structure or its foundation.

**Shotcrete** – Concrete sprayed through a nozzle onto the surface to be covered.

**Sinkhole** – A depression that indicates sub-surface settlement or particle movement, typically having clearly defined boundaries with a sharp offset.

**Significant wave height** – Average height of the one-third highest individual waves. Can be estimated from wind speed, fetch length, and wind duration

**Siphon** – An inverted U-shaped pipe or conduit, filled until atmospheric pressure is enough to force water from a reservoir over an embankment dam and out of the other end.

**Slide** – Movement of a mass of earth down a slope on the embankment or abutment of a dam.

**Slide gate** – A gate that can be opened or closed by sliding in supporting guides.

**Slurry trench** – A trench cut into an embankment or its foundation and filled with a flexible watertight slurry to prevent the passage of water.

**Spillway** – A structure over or through which flow is discharged from a reservoir. If the rate of flow is controlled by mechanical means, such as gates, it is considered a controlled spillway. If the geometry of the spillway is the only control, it is considered an uncontrolled spillway.

**Stilling basin** – A basin constructed to dissipate the energy of rapidly flowing water, e.g., from a spillway or outlet, and to protect the riverbed from erosion.

**Stillwater level** – The elevation that a water surface would assume if all wave actions were absent.

**Stoplogs** – Large logs, timbers, or steel beams placed on top of each other with

their ends held in guides on each side of a channel or conduit to provide a cheaper or more easily handled means of temporary closure than a bulkhead gate.

**Toe drain** – A system of pipe and/or pervious material along the downstream toe of a dam used to collect seepage from the foundation and embankment and convey it to a free outlet.

**Toe of dam** – The junction of the downstream slope or face of a dam with the ground surface; also referred to as the downstream toe. The junction of the upstream slope with the ground surface is called the heel or the upstream toe.

**Top thickness (top width)** – The thickness or width of a dam at the level of the top of the dam (excluding corbels or parapets). In general, the term thickness is used for gravity and arch dams, and width is used for other dams.

**Trash rack** – A device found at an intake to prevent floating or submerged debris from entering the intake.

**Uplift** – The hydrostatic force of water exerted on or underneath a structure, tending to cause a displacement of the structure.

**Volume of dam** – The total space occupied by the materials forming the dam structure computed between abutments and from top to bottom of the dam. No deduction is made for small openings such as galleries, adits, tunnels, and operating chambers within the dam structure. The volumes of power plants, locks, and spillways are included only

if they are needed for structural stability of the dam.

**Wave protection** – Riprap, concrete, or other armoring on the upstream face of an embankment dam to protect against scouring or erosion caused by wave action.

**Wave runup** – Vertical height above the stillwater level to which water from a specific wave will run up the face of a structure or embankment.

**Weir** – A barrier across a stream designed to alter its flow characteristics. In most cases, weirs take the form of obstructions smaller than conventional dams, pooling water behind them while also allowing it to flow steadily over their tops.

**Weir, broad-crested** – An overflow structure on which the nappe is supported for an appreciable length in the direction of flow.

**Weir, measuring** – A device for measuring the rate of flow of water. It consists of a rectangular, trapezoidal, triangular, or another shaped notch, located in a vertical, thin plate over which water flows. The height of water above the weir crest is used to determine the rate of flow.

**Weir, ogee** – A reverse curve, shaped like an elongated letter "S." The downstream faces of overflow spillways are often made to this shape.

**Wind setup** – The vertical rise in the stillwater level at the face of a structure or embankment caused by the wind stresses acting on the surface of the water.

This page has been left blank intentionally.

This page has been left blank intentionally.

# Central Dam Safety Organization Central Water Commission

## Vision

To remain as a premier organization with best technical and managerial expertise for providing advisory services on matters relating to dam safety.

## Mission

To provide expert services to State Dam Safety Organizations, dam owners, dam operating agencies and others concerned for ensuring safe functioning of dams with a view to protect human life, property and the environment.

## Values

**Integrity:** Act with integrity and honesty in all our actions and practices.

**Commitment:** Ensure good working conditions for employees and encourage professional excellence.

**Transparency:** Ensure clear, accurate and complete information in communications with stakeholders and take all decisions openly based on reliable information.

**Quality of service:** Provide state-of-the-art technical and managerial services within agreed time frame.

**Striving towards excellence:** Promote continual improvement as an integral part of our working and strive towards excellence in all our endeavours.

## Quality Policy

We provide technical and managerial assistance to dam owners and State Dam Safety Organizations for proper surveillance, inspection, operation and maintenance of all dams and appurtenant works in India to ensure safe functioning of dams and protecting human life, property and the environment.

We develop and nurture competent manpower and equip ourselves with state of the art technical infrastructure to provide expert services to all stakeholders.

We continually improve our systems, processes and services to ensure satisfaction of our customers.

